



UNITEDSEATS

**CONSTRUCTEUR DE
SIEGES HORS ROUTE**



SEATING PRO CONCEPT



Sommaire



Sièges

page **04**



Suspensions

page **05**



Véhicule de construction BTP

page **06**



Engins agricoles

page **08**



Chariots élévateurs

page **10**



Petits véhicules

page **12**



Accessoires et options

page **50**





en



A propos de UnitedSeats

UnitedSeats est un fabricant mondial pour divers sièges hors route. Nous fournissons des sièges dans les secteurs de la construction, de l'agriculture, de la marine et de l'industrie.

Tous les sièges sont fabriqués dans notre usine moderne de 75.000m² utilisant les dernières techniques de fabrication. Nous distribuons des sièges et composants à travers un réseau de distribution mondial depuis nos installations de Zwijndrecht aux Pays-Bas.



UnitedSeats reste attaché à l'innovation, fournir des solutions de sièges par son soutien aux services techniques et commerciaux. Nos capacités internes nous permettent d'adapter le produit aux spécification des clients.

Notre gamme de sièges hors route offre aux agriculteurs, aux entrepreneurs et aux utilisateurs industriels une large gamme.

Cette gamme comprend des suspensions pneumatiques et mécaniques avec une large choix de revêtement luxueux du tissu au PVC.



Chez UnitedSeats, notre priorité est d'assurer la santé et la sécurité des conducteurs de véhicules de travail, et nous vous recommandons de remplacer ou réparer les sièges anciens ou endommagés pour éviter les blessures.

Chez UnitedSeats, nous sommes de retour !



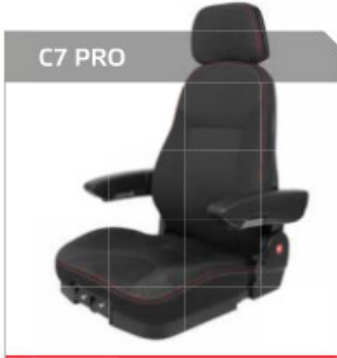



*Nous assemblons
votre siège*

La gamme comprend des suspensions pneumatiques et mécaniques avec une large gamme de revêtement de luxe du tissu au PVC.





SIEGES POUR VEHICULES DE CONSTRUCTION





LGV 90 - C7 PRO  Page Seite 14	CS 85 - C7 PRO  Page Seite 15	LGV 90 - C2 PRO  Page Seite 16	CS 85 - C2 PRO  Page Seite 17	CS 85 - C1  Page Seite 20	CS 85 - C4  Page Seite 21	LGV 84 - C1  Page Seite 22	MGV 84 - C1  Page Seite 23	LGV 90 - TOP 25  Page Seite 28
LGV 84 - Top 15  Page Seite 29	CS 85 - Top 25  Page Seite 30	CS 85 - H 90  Page Seite 31	LGV 84 - C6  Page Seite 36	MGV 84 - C6  Page Seite 37				





SIEGES POUR VEHICULES D'AGRICULTURE





LGV 90 - C7 PRO  Page Seite 14	CS 85 - C7 PRO  Page Seite 15	LGV 90 - C2 PRO  Page Seite 16	CS 85 - C2 PRO  Page Seite 17	LGV 35 - C2  Page Seite 18	CS 85 - C1  Page Seite 20	CS 85 - C4  Page Seite 21	LGV 84 - C1  Page Seite 22	MGV 84 - C1  Page Seite 23
LGV90 - Top 25  Page Seite 28	LGV 84 - Top 15  Page Seite 29	CS 85 - Top 25  Page Seite 30	CS 85 - H 90  Page Seite 31	LGV 35 - Top 25  Page Seite 32	MGV 35  Page Seite 33	LGV 84 - C6  Page Seite 36	MGV 84 - C6  Page Seite 37	LGV 84 - 440V  Page Seite 38
LGV 84 - Mi 400  Page Seite 39	MGV 84 - Mi 400  Page Seite 40	MGV 84 - Mi 560  Page Seite 41	ML 5010 Vario  Page Seite 44	ML 4010  Page Seite 45	T 600  Page Seite 46	5010mmF  Page Seite 47	W 700  Page Seite 48	T 700  Page Seite 49





SIEGES POUR CHARIOTS ELEVATEURS





LGV 35 - C2  Page Seite 18	MGV 64 - C2  Page Seite 19	LGV 35 - C1  Page Seite 24	MGV 25 - C1  Page Seite 25	LGV 35 - C5  Page Seite 26	MGV 25 - C5  Page Seite 27	CS 85 - Top 25  Page Seite 30	CS 85 - H 90  Page Seite 31	LGV 35 - Top 25  Page Seite 32
MGV 35  Page Seite 33	MGV 20 - C1 SM  Page Seite 34	MGV 15  Page Seite 35	MGV 25  Page Seite 42	GS 20  Page Seite 43				





SIEGES POUR PETITS VEHICULES





LGV 35 - C2  Page Seite 18	MGV 64 - C2  Page Seite 19	LGV 35 - C1  Page Seite 24	MGV 25 - C1  Page Seite 25	LGV 35 - C5  Page Seite 26	MGV 25 - C5  Page Seite 27	LGV90 - Top 25  Page Seite 28	LGV 84 - Top 15  Page Seite 29	LGV 35 - Top 25  Page Seite 32
MGV 35  Page Seite 33	MGV 20 - C1 SM  Page Seite 34	MGV 15  Page Seite 35	LGV 84 - 440V  Page Seite 38	LGV 84 - Mi 400  Page Seite 39	MGV 84 - Mi 400  Page Seite 40	MGV 84 - Mi 560  Page Seite 41	MGV 25  Page Seite 42	GS 20  Page Seite 43
T 600  Page Seite 46	W 700  Page Seite 48	T 700  Page Seite 49						





LGV 90 - C7 PRO



Ce siège est adapté à tous les types de machines de construction et engins agricoles. La série PRO a plusieurs réglables de fonctionnalités

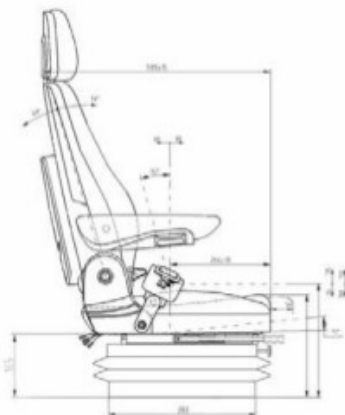
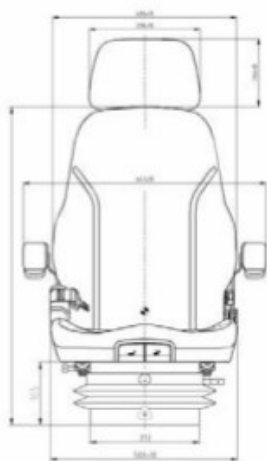

CARACTÉRISTIQUES

- Suspension pneumatique avec compresseur intégré 12v
- Réglage du poids semi-automatique
- Ajustement de poids de 50-130 kg
- Course de suspension 120 mm
- Ajustement de la hauteur en continu 80mm
- Rail de glissière : 200mm
- Suspension horizontale
- Revêtement de tissu UnitedSeats
- Dossier haut et réglable
- Largeur du siège de 490mm
- Réglage en profondeur du coussin d'assise et de l'inclinaison

OPTIONS

- Compresseur 24v ou 48v
- Revêtement en PVC robuste
- Soutien lombaire pneumatique
- Accoudoirs avec bras réglables
- Appui-tête, Ceinture de sécurité, Contacteur de présence
- Élément chauffant 12, 24 ou 48v
- Plaque tournante, boîte à documents





CS 85 - C7 PRO



Ce siège est adapté à tous les types de machines de construction et engins agricoles. La série PRO a plusieurs réglables de fonctionnalités

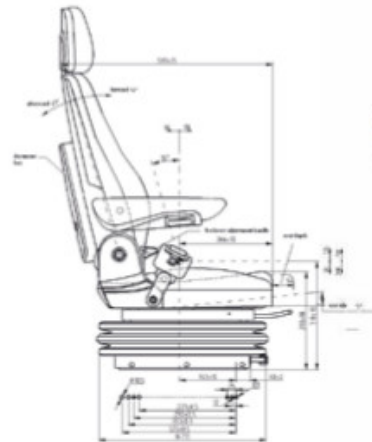
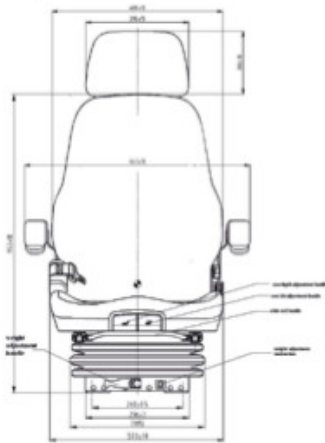

CARACTÉRISTIQUES

- Suspension mécanique
- Ajustement de poids de 50-125 kg
- Course de suspension 90 mm
- Réglage de la hauteur de 60mm en 3 étapes
- Rail de glissière : 200 mm
- Revêtement de tissu UnitedSeats
- Largeur du siège de 490 mm
- Dossier réglable
- Réglage en profondeur du coussin d'assise et de l'inclinaison

OPTIONS

- Revêtement en PVC robuste
- Soutien lombaire pneumatique
- Accoudoirs avec bras réglables
- Appui-tête
- Ceinture de sécurité, Contacteur de présence
- Élément chauffant 12, 24 ou 48v
- Plaque tournante, Boîte à documents

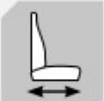



LGV 90 - C2 PRO



Ce siège est adapté à tous les types de machines de construction et engins agricoles. La série PRO a plusieurs réglables de fonctionnalités

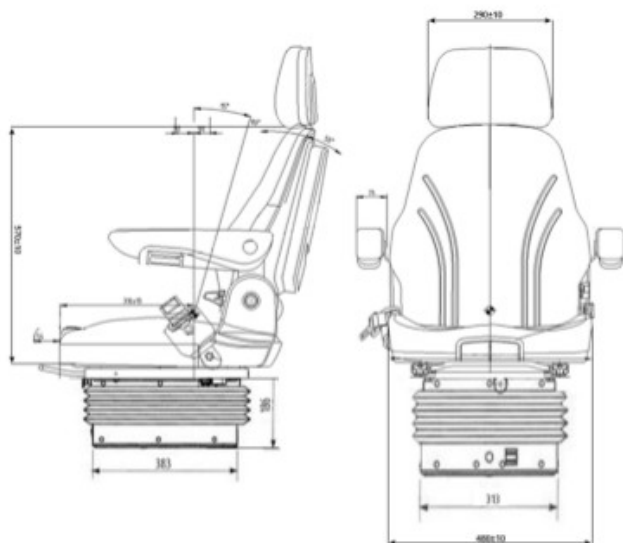

CARACTÉRISTIQUES STANDARDS

- Suspension pneumatique avec compresseur intégré 12v
- Réglage du poids semi-automatique
- Ajustement de poids de 50-130 kg
- Course de suspension 120 mm
- Ajustement de la hauteur en continu 80 mm
- Rail de glissière 200 mm
- Suspension horizontale
- Revêtement de tissu UnitedSeats
- Largeur du siège de 490 mm
- Dossier réglable
- Réglage en profondeur du coussin d'assise et de l'inclinaison

OPTIONS

- Compresseur 24v ou 48v
- Revêtement en PVC robuste
- Soutien lombaire pneumatique
- Accoudoirs avec bras réglables
- Appui-tête, Ceinture de sécurité, Contacteur de présence
- Élément chauffant 12, 24 ou 48v
- Plaque tournante, Boîte à documents





LGV 35 - C2



Ce siège est adapté à tous les types de machines agricoles, chariots élévateurs et autres petites machines. Disponible avec plusieurs options.
Disponible en version PRO.

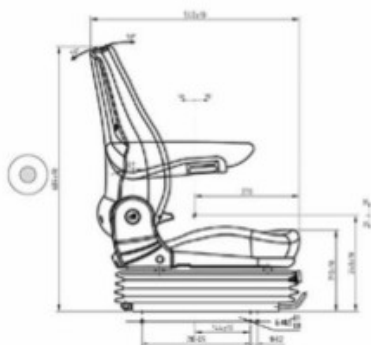
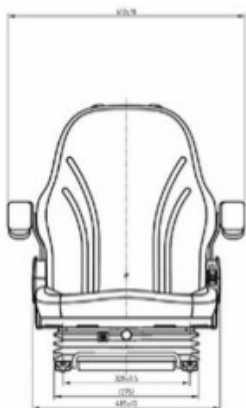

CARACTÉRISTIQUES

- Suspension pneumatique compacte avec compresseur 12v intégré
- Réglage du poids 45-150 kg
- Course de suspension 60 mm
- Rail de glissière : 200 mm
- Revêtement de tissu UnitedSeats
- Largeur du siège 490 mm
- Dossier réglable

OPTIONS

- Compresseur 24 ou 48v
- Revêtement en PVC robuste
- Soutien lombaire pneumatique
- Accoudoirs avec bras réglables
- Extension de dossier
- Ceinture de sécurité
- Contacteur de présence
- Élément chauffant 12, 24 ou 48v
- Plaque tournante, Boîte à documents
- Version PRO avec profondeur et inclinaison du siège réglable

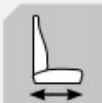



MGV 64 - C2



Ce siège est adapté à tous les types de machines agricoles, chariots élévateurs et autres petites machines.
Disponible avec plusieurs options.
Disponible en version PRO.

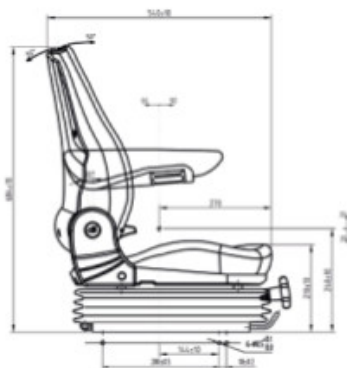
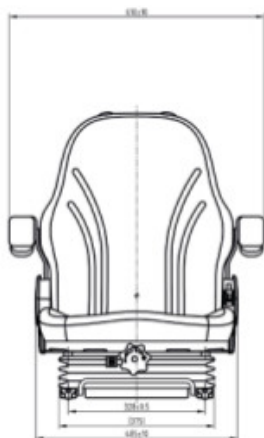

CARACTÉRISTIQUES

- Suspension mécanique compacte
- Réglage du poids 45-145 kg
- Course de suspension 60 mm
- Rail de glissière : 200 mm
- Revêtement PVC robuste
- Largeur du siège 490 mm
- Dossier réglable

OPTIONS

- Revêtement tissu UnitedSeats
- Accoudoirs avec bras réglables
- Soutien lombaire pneumatique
- Extension de dossier
- Ceinture de sécurité
- Contacteur de présence
- Élément chauffant 12, 24 ou 48v
- Plaque tournante, Boîte à documents
- Version PRO avec profondeur et inclinaison du siège réglable





CS 85 - C1



Ce siège est adapté à tous les types de véhicules de construction et les machines agricoles. Disponible avec plusieurs options dont une version étroite.

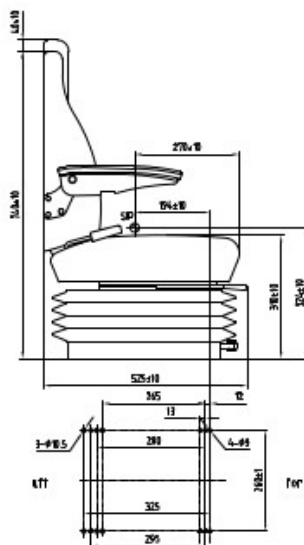
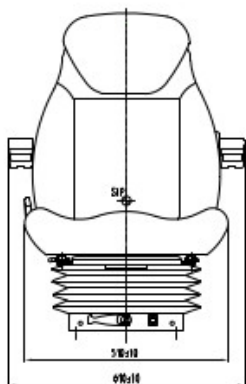

CARACTÉRISTIQUES

- Suspension mécanique
- Ajustement de poids de 50-125 kg
- Course de suspension 90 mm
- Réglage de la hauteur de 60 mm en 3 étapes
- Rail de glissière : 150 mm
- Revêtement de tissu UnitedSeats
- Largeur du siège de 510 mm
- Support lombaire mécanique
- Dossier réglable
- Versions étroites de 390 ou 430 mm

OPTIONS

- Diverses options de PVC et de tissu
- Accoudoirs avec bras réglables
- Extension de dossier
- Ceinture de sécurité
- Contacteur de présence
- Élément chauffant 12, 24 ou 48v
- Plaque tournante

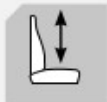



CS 85 - C4



Ce siège est adapté à tous les types de véhicules de construction et les machines agricoles. Disponible avec plusieurs options.

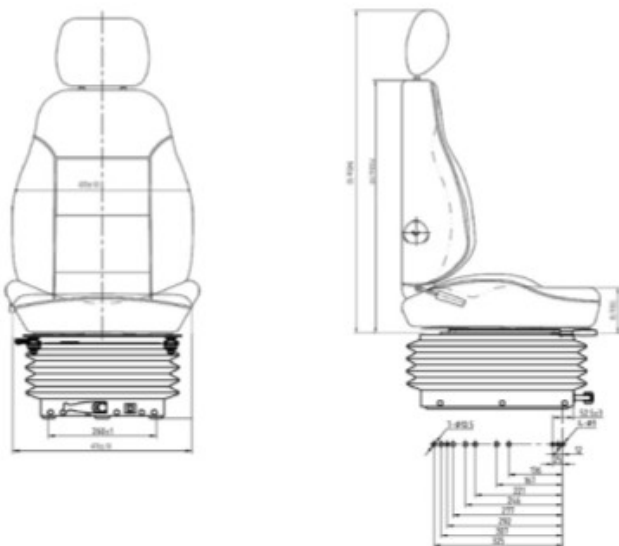

CARACTÉRISTIQUES

- Suspension mécanique
- Ajustement de poids de 50-125 kg
- Course de suspension 90 mm
- Réglage de la hauteur de 60 mm en 3 étapes
- Rail de glissière : 150 mm
- Revêtement de tissu UnitedSeats
- Largeur du siège de 480 mm
- Support lombaire mécanique
- Dossier réglable

OPTIONS

- Revêtement en PVC
- Accoudoirs avec bras réglables
- Appui-tête
- Ceinture de sécurité
- Contacteur de présence
- Élément chauffant 12, 24 ou 48v
- Plaque tournante

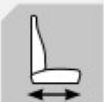



LGV 84 - C1

Ce siège est adapté à tous les types de véhicules de construction et les machines agricoles.
Disponible avec plusieurs options.

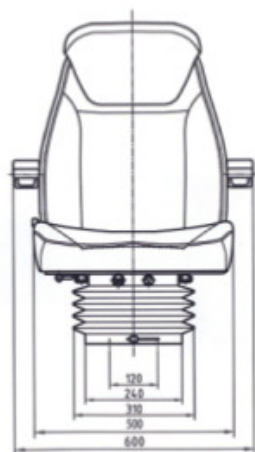
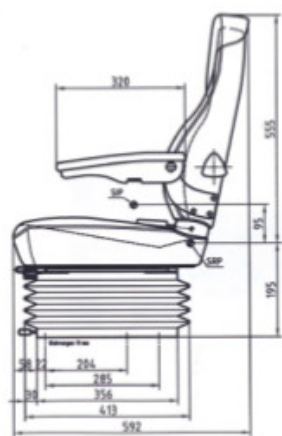

CARACTÉRISTIQUES

- Petite suspension pneumatique avec compresseur 12v intégré
- Réglage du poids semi-automatique
- Ajustement de poids de 50-130 kg
- Course de suspension 100 mm
- Suspension horizontale
- Ajustement de taille de 80-140 mm
- Glissière de rail : 150 mm
- Revêtement de tissu UnitedSeats
- Largeur du siège de 510 mm
- Support lombaire mécanique
- Dossier réglable

OPTIONS

- Compresseur 24v ou 48v
- Diverses options de PVC et de tissu
- Accoudoirs avec bras réglables
- Extension de dossier, Plateau tournant
- Ceinture de sécurité, Contacteur de présence
- Élément chauffant 12, 24 ou 48v
- Versions étroites de 390 ou 430 mm

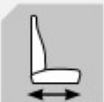



MGV 84 - C1

Ce siège est adapté à tous les types de véhicules de construction et les machines agricoles. Disponible avec plusieurs options.

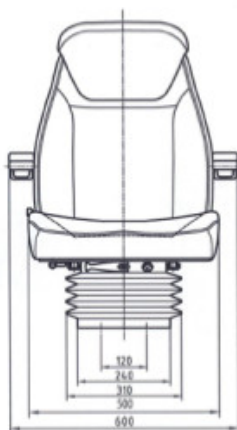
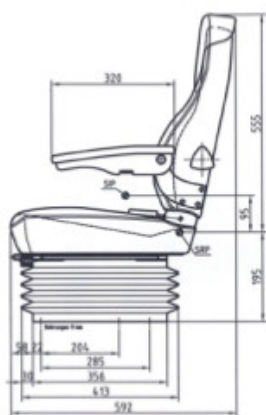

CARACTÉRISTIQUES

- Suspension mécanique
- Ajustement de poids de 50-120 kg
- Course de suspension 100 mm
- Réglage de la hauteur 60 mm
- Glissière de rail :150 mm
- Revêtement de tissu UnitedSeats
- Largeur du siège de 510 mm
- Support lombaire mécanique
- Dossier réglable

OPTIONS

- Diverses options de PVC et de tissu
- Accoudoirs avec bras réglables
- Extension de dossier
- Plateau tournant
- Ceinture de sécurité
- Contacteur de présence
- Élément chauffant 12, 24 ou 48 v
- Versions étroites de 390 ou 430 mm

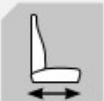



LGV 35 - C1



Ce siège est adapté à tous les types de machines agricoles, chariots élévateurs et autres petites machines. Disponible avec plusieurs options.
Disponible en version PRO.

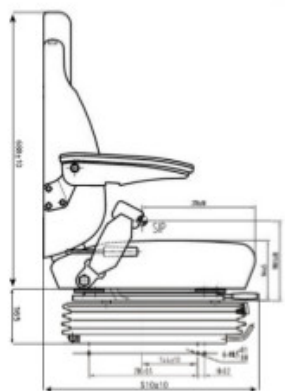
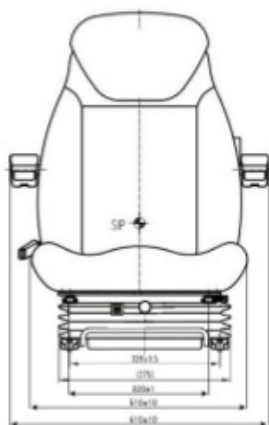

CARACTÉRISTIQUES

- Suspension pneumatique compacte avec compresseur 12v intégré
- Réglage du poids 45-150 kg
- Course de suspension 60 mm
- Rail de glissière : 200 mm
- Revêtement de tissu UnitedSeats
- Largeur du siège 510 mm
- Support lombaire mécanique
- Dossier réglable

OPTIONS

- Compresseur 24 ou 48v
- Diverses options PVC ou tissu
- Accoudoirs avec bras réglables
- Extension de dossier
- Ceinture de sécurité
- Contacteur de présence
- Élément chauffant 12, 24 ou 48 v
- Plateau tournant
- Versions étroites 390 mm et 430 mm





MGV 25 - C1



Ce siège est adapté à tous les types de chariots élévateurs et autres petites machines. Disponible avec plusieurs options.

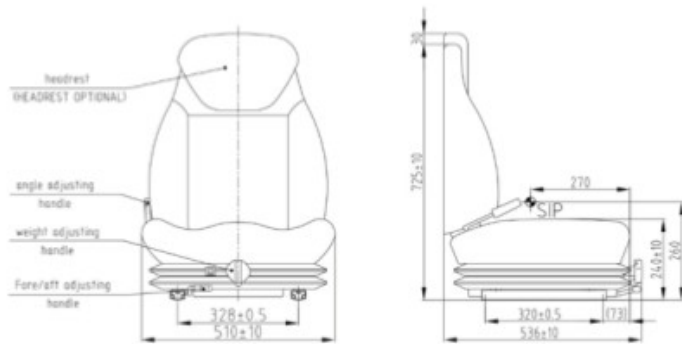

CARACTÉRISTIQUES

- Suspension mécanique
- Ajustement de poids 50-130 kg
- Course de suspension 45 mm
- Glissière de rail : 150 mm
- Revêtement de tissu UnitedSeats
- Largeur du siège 510 mm
- Support lombaire mécanique
- Dossier réglable

OPTIONS

- Diverses options de PVC et de tissu
- Accoudoirs avec bras réglables
- Extension de dossier
- Ceinture de sécurité à 2 points
- Contacteur de présence
- Élément chauffant 12, 24 ou 48 v
- Versions étroites de 390 ou 430 mm





LGV 35 - C5



Ce siège est adapté à tous les types de chariots élévateurs et autres petites machines. Disponible avec plusieurs options.

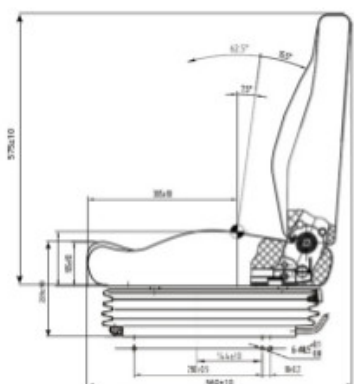

CARACTÉRISTIQUES

- Suspension pneumatique compacte avec compresseur 12v intégré
- Réglage du poids 45-150 kg
- Course de suspension 60 mm
- Rail de glissière : 200 mm
- Revêtement de tissu UnitedSeats
- Largeur du siège 460 mm
- Support lombaire mécanique
- Dossier réglable

OPTIONS

- Compresseur 24 ou 48 v
- Diverses options PVC ou tissu
- Soutien lombaire pneumatique
- Accoudoirs réglables
- Extension de dossier
- Ceinture de sécurité
- Contacteur de présence
- Élément chauffant 12, 24 ou 48 v
- Plateau tournant





MGV 25 - C5



Ce siège est adapté à tous les types de chariots élévateurs et autres petites machines. Disponible avec plusieurs options.

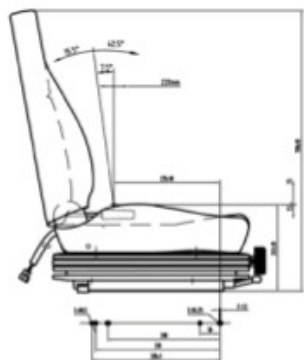
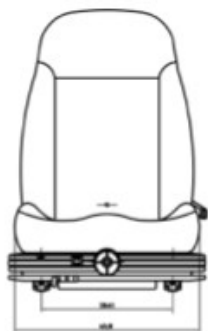

CARACTÉRISTIQUES

- Suspension mécanique
- Ajustement de poids 50-130 kg
- Course de suspension 45 mm
- Rail de glissière 150 mm
- Revêtement de tissu UnitedSeats
- Largeur du siège 510 mm
- Dossier réglable

OPTIONS

- Diverses options PVC et tissu
- Soutien lombaire pneumatique
- Accoudoirs réglables
- Extension de dossier
- Ceinture de sécurité
- Contacteur de présence
- Élément chauffant 12, 24 ou 48v





LGV 90 - TOP 25



Ce siège est adapté à tous les types de machines agricoles, engins de construction et autres petites machines. Disponible avec plusieurs options.

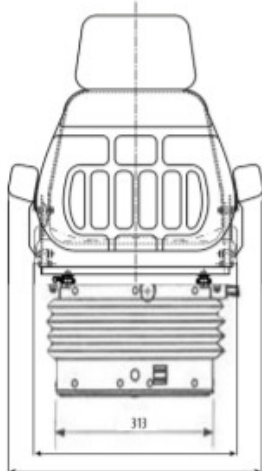
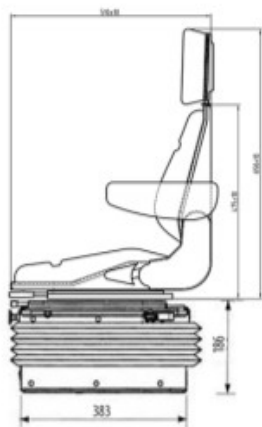

CARACTÉRISTIQUES

- Suspension pneumatique avec compresseur 12v intégré
- Réglage du poids semi-automatique
- Ajustement du poids 50-130 kg
- Course de suspension 80 mm
- Rail de glissière : 200 mm
- Réglage de la hauteur en continu 60 mm
- Revêtement de tissu noir
- Largeur du siège 510 mm
- Suspension horizontale
- Dossier repliable et réglable

OPTIONS

- Compresseur 24 ou 48 v
- Diverses options PVC robuste
- Accoudoirs
- Extension de dossier
- Ceinture de sécurité
- Contacteur de présence
- Plateau tournant

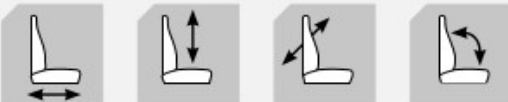



LGV 84 - TOP 15



Ce siège est adapté à tous les types de machines agricoles, engins de construction et autres petites machines. Disponible avec plusieurs options.

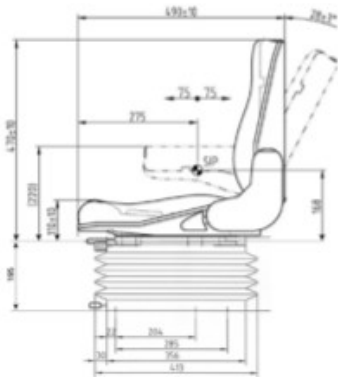

CARACTÉRISTIQUES

- Suspension pneumatique compacte avec compresseur 12v intégré
- Réglage du poids semi-automatique
- Ajustement du poids 50-130 kg
- Course de suspension : 100 mm
- Ajustement de la taille : 80 à 140 mm
- Rail de glissière : 150 mm
- Suspension horizontale
- Revêtement de tissu noir
- Largeur du siège 490 mm
- Dossier repliable et réglable

OPTIONS

- Compresseur 24 ou 48 v
- Revêtement PVC robuste
- Accoudoirs
- Ceinture de sécurité
- Contacteur de présence
- Plaque tournante





CS 85 - TOP 25



Ce siège est adapté à tous les types de machines agricoles, engins de construction et chariots élévateurs. Disponible avec plusieurs options.

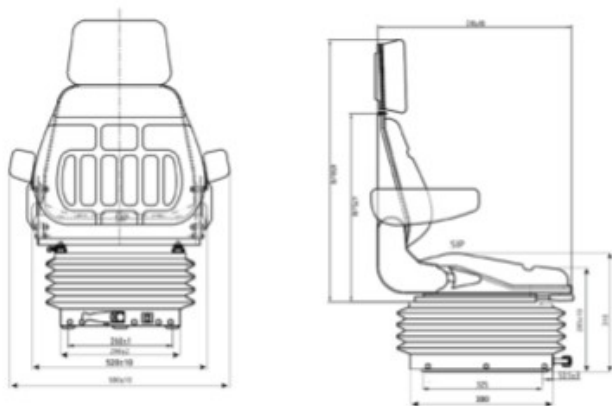

CARACTÉRISTIQUES

- Suspension mécanique
- Ajustement de poids 50-125 kg
- Course de suspension 90 mm
- Réglage de la hauteur 60 mm en 3 étapes
- Glissière de rail : 200 mm
- Revêtement de tissu noir
- Largeur du siège 510 mm
- Dossier repliable et réglable

OPTIONS

- Revêtement en PVC robuste
- Accoudoirs
- Extension de dossier
- Ceinture de sécurité
- Contacteur de présence
- Plaque tournante





CS 85 - H90



Ce siège est adapté à tous les types de machines agricoles, engins de construction et chariots élévateurs.
Disponible avec plusieurs options.

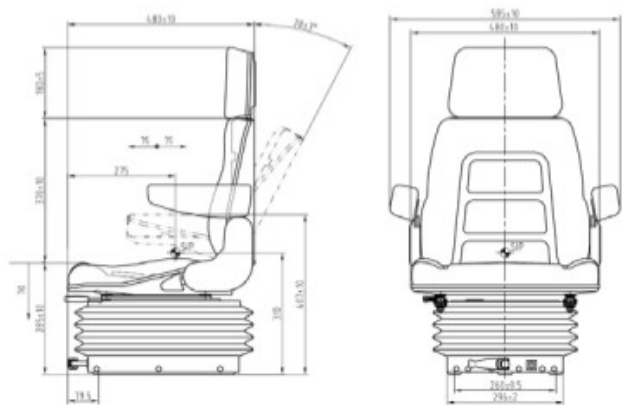

CARACTÉRISTIQUES

- Suspension mécanique
- Ajustement de poids 50-125 kg
- Course de suspension 90 mm
- Réglage en hauteur de 60 mm en 3 étapes
- Rail de glissière 150 mm
- Revêtement de tissu noir
- Largeur du siège 510 mm
- Dossier repliable et réglable

OPTIONS

- Revêtement PVC robuste
- Accoudoirs
- Extension de dossier
- Ceinture de sécurité
- Contacteur de présence
- Plaque tournante





LGV 35 - TOP 25



Ce siège est adapté à tous les types de machines agricoles, chariots élévateurs et autres petites machines. Disponible avec plusieurs options.

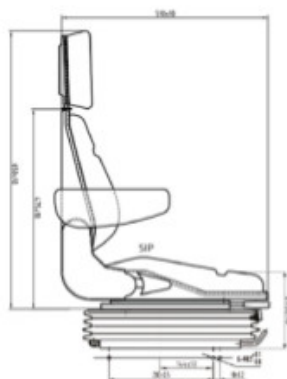
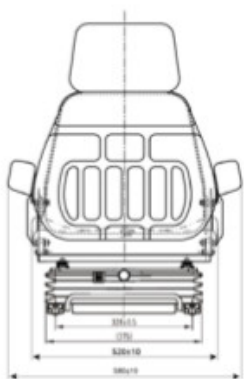

CARACTÉRISTIQUES

- Suspension pneumatique compacte avec compresseur 12v intégré
- Réglage du poids 45-150 kg
- Course de suspension 60 mm
- Rail de glissière : 200 mm
- Revêtement de tissu noir
- Largeur du siège 510 mm
- Dossier repliable et réglable

OPTIONS

- Compresseur 24 ou 48 v
- Revêtement PVC robuste
- Accoudoirs
- Extension de dossier
- Ceinture de sécurité
- Contacteur de présence
- Plaque tournante





MGV 35



Ce siège est adapté à tous les types de machines agricoles, engins de construction et chariots élévateurs. Disponible avec plusieurs options.

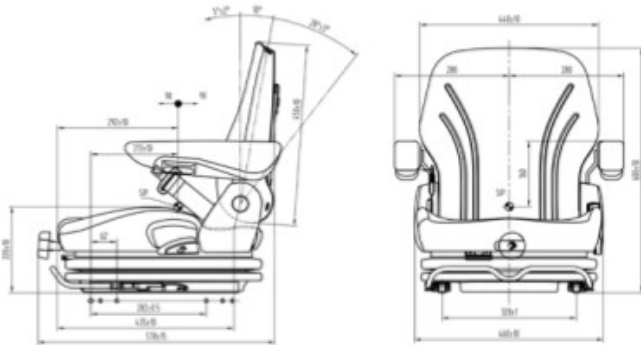

CARACTÉRISTIQUES

- Suspension mécanique
- Ajustement de poids 50-130 kg
- Course de suspension 80 mm
- Rail de glissière 180 mm
- Revêtement en PVC robuste
- Largeur du siège 460 mm
- Dossier repliable et réglable
- Ceinture de sécurité

OPTIONS

- Revêtement tissu UnitedSeats
- Support lombaire mécanique
- Accoudoirs réglables
- Appui-tête
- Contacteur de présence





MGV 20 - C1 SM



Ce siège est adapté à tous les types de machines agricoles, chariots élévateurs et autres petites machines. Disponible avec plusieurs options.

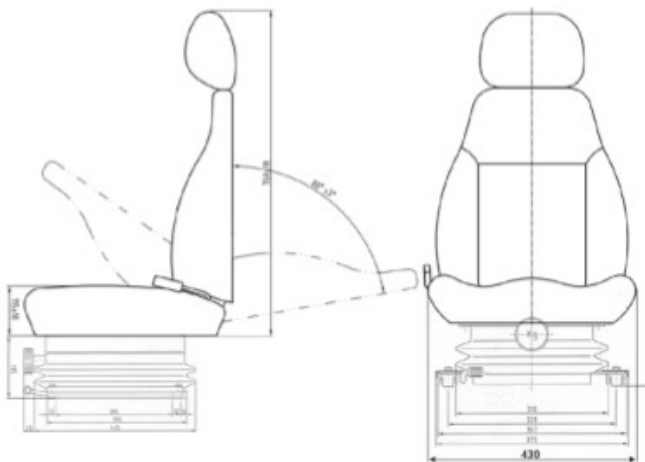

CARACTÉRISTIQUES

- Suspension mécanique compacte
- Réglage du poids 50-120 kg
- Course de suspension 45 mm
- Rail de glissière : 200 mm
- Revêtement en tissu UNitedSeats
- Largeur du siège 390 mm ou 430 mm
- Support lombaire mécanique
- Dossier réglable

OPTIONS

- Diverses options PVC et tissu
- Accoudoirs avec bras réglables
- Extension de dossier
- Ceinture de sécurité 2 ou 3 points
- Contacteur de présence
- Élément chauffant 12, 24 ou 48 v
- Egalement disponible en largeur 510 mm





MGV 15



Ce siège est adapté à tous les types de chariots élévateurs et autres petites machines. Disponible avec plusieurs options.

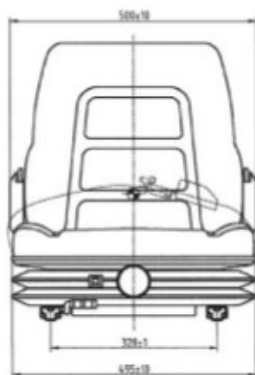
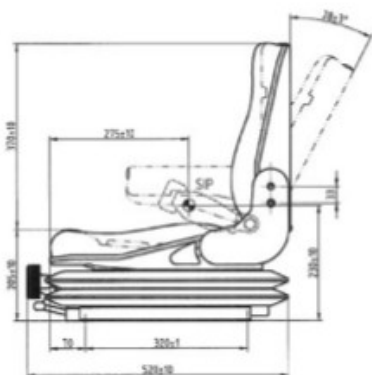

CARACTÉRISTIQUES

- Suspension mécanique
- Ajustement de poids 50-120 kg
- Course de suspension 45 mm
- Rail de glissière 150 mm
- Revêtement en tissu noir
- Largeur du siège 490 mm
- Dossier réglable

OPTIONS

- Revêtement PVC résistant
- Accoudoirs
- Ceinture de sécurité
- Contacteur de présence





LGV 84 - C6



Ce siège est adapté à tous les types de véhicules de construction et les machines agricoles. Disponible avec plusieurs options.

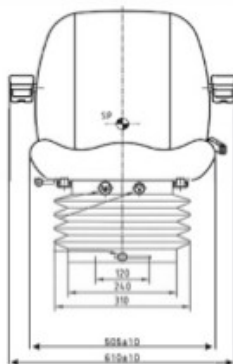
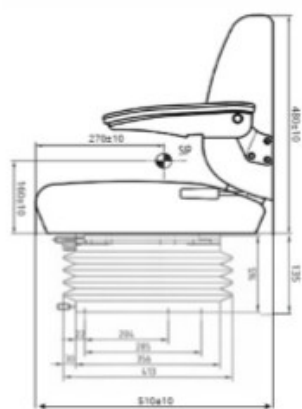

CARACTÉRISTIQUES

- Suspension pneumatique compacte avec compresseur 12v intégré
- Réglage du poids semi automatique
- Ajustement du poids 50-130 kg
- Course de suspension 100 mm
- Ajustement de la taille 80 à 140 mm
- Rail de glissière : 150 mm
- Revêtement de tissu UnitedSeats
- Suspension horizontale
- Largeur du siège 510 mm
- Dossier réglable
- Accoudoirs

OPTIONS

- Compresseur 24 ou 48 v
- Revêtement bicolore ou PVC Wild Heather
- Soutien lombaire pneumatique
- Ceinture de sécurité
- Contacteur de présence
- Élément chauffant 12, 24 ou 48 V
- Plaque tournante





MGV 84 - C6



Ce siège est adapté à tous les types de véhicules de construction et les machines agricoles. Disponible avec plusieurs options.

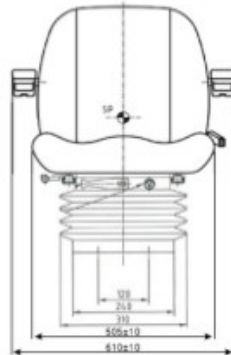
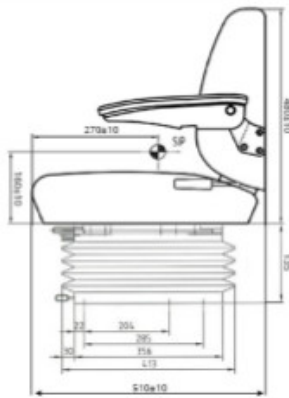

CARACTÉRISTIQUES

- Suspension mécanique
- Ajustement de poids 50-120 kg
- Course de suspension 100 mm
- Réglage de la hauteur de 60 mm
- Rail de glissière 150 mm
- Revêtement en PVC bicolore
- Largeur du siège 510 mm
- Dossier réglable
- Accoudoirs réglables

OPTIONS

- Revêtement PVC Wild Heather ou tissu UnitedSeats
- Soutien lombaire pneumatique
- Ceinture de sécurité
- Contacteur de présence
- Élément chauffant 12, 24 ou 48 V
- Plaque tournante

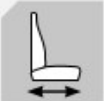



LGV 84 - 440V



Ce siège est adapté à tous les types de machines agricoles et autres petites machines. Disponible avec plusieurs options.

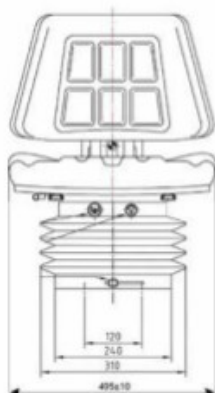
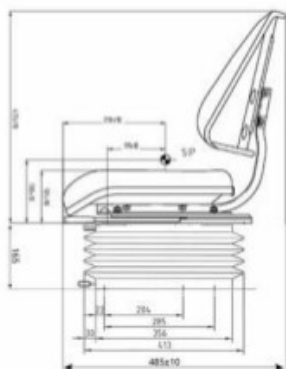

CARACTÉRISTIQUES

- Suspension pneumatique compacte avec compresseur 12 v intégré
- Réglage du poids semi automatique
- Ajustement du poids 50-130 kg
- Course de suspension 100 mm
- Ajustement de la taille 80 à 140 mm
- Rail de glissière : 150 mm
- Suspension horizontale
- Revêtement PVC noir
- Largeur du siège 490 mm
- Dossier réglable

OPTIONS

- Compresseur 24 ou 48 v
- Revêtement tissu
- Ceinture de sécurité
- Contacteur de présence
- Plaque tournante





LGV 84 - Mi400



Ce siège est adapté à tous les types de machines agricoles et autres petites machines. Disponible avec plusieurs options.

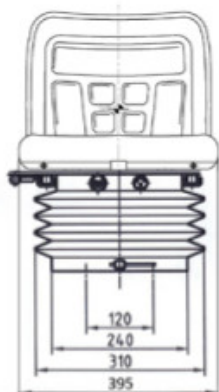
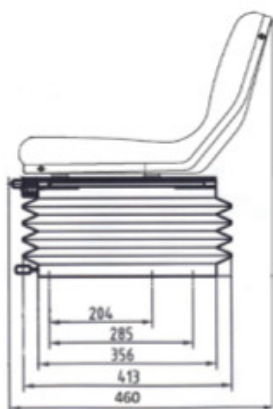

CARACTÉRISTIQUES

- Suspension pneumatique avec compresseur 12v intégré
- Réglage du poids semi automatique
- Ajustement du poids 50-130 kg
- Course de suspension 100 mm
- Ajustement de la taille 80 à 140 mm
- Rail de glissière : 150 mm
- Suspension horizontale
- Revêtement et mousse résistante à l'eau d'une seule pièce avec drainage en PVC noir
- Largeur du siège cuvette 400 mm

OPTIONS

- Compresseur 24 ou 48 v
- Revêtement tissu
- Accoudoirs
- Ceinture de sécurité
- Contacteur de présence
- Plateau tournant
- Assise plus large Mi 560 (largeur 500 mm)

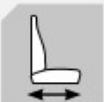



MGV 84 - Mi400



Ce siège est adapté à tous les types de machines agricoles et autres petites machines. Disponible avec plusieurs options.

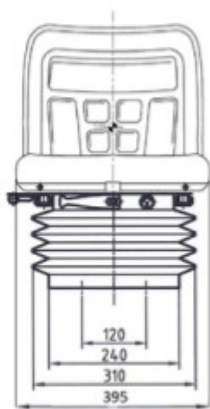
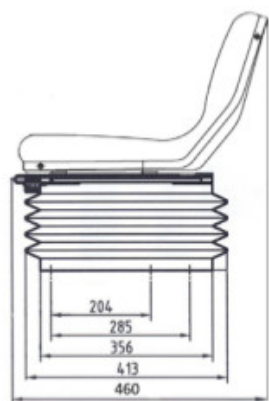

CARACTÉRISTIQUES

- Petite suspension mécanique
- Ajustement du poids 50-120 kg
- Course de suspension 100 mm
- Réglage en hauteur de 60 mm
- Rail de glissière : 150 mm
- Largeur du siège/cuvette 400 mm
- Revêtement et mousse résistante à l'eau d'une seule pièce avec drainage en PVC noir

OPTIONS

- Accoudoirs
- Ceinture de sécurité
- Contacteur de présence
- Plateau tournant
- Assise plus large Mi 500 (largeur 500 mm)

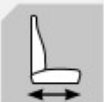



MGV 84 - Mi560



Ce siège est adapté à tous les types de machines agricoles et autres petites machines. Disponible avec plusieurs options.

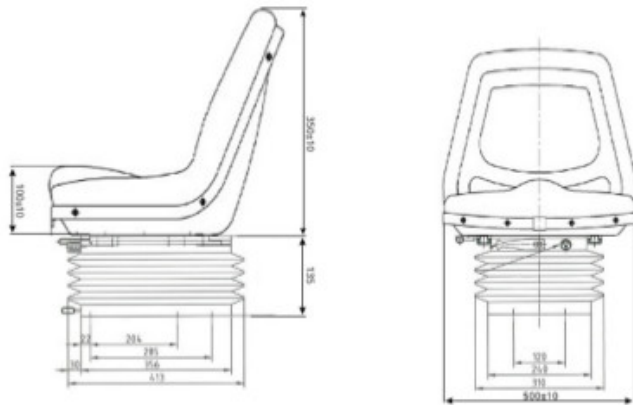

CARACTÉRISTIQUES

- Petite suspension mécanique
- Ajustement du poids 50-120 kg
- Course de suspension 100 mm
- Réglage en hauteur de 60 mm
- Rail de glissière : 150 mm
- Largeur du siège/cuvette 500 mm
- Revêtement et mousse résistante à l'eau d'une seule pièce avec drainage en PVC noir

OPTIONS

- Accoudoirs
- Ceinture de sécurité
- Contacteur de présence
- Plaque tournante
- Assise plus étroite Mi 400 (largeur 400 mm)





MGV 25



Ce siège est adapté à tous les types de chariots élévateurs et autres petites machines. Disponible avec plusieurs options.

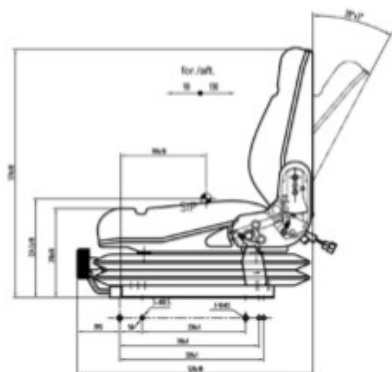

CARACTÉRISTIQUES

- Suspension mécanique
- Ajustement de poids 50-130 kg
- Course de suspension 40 mm
- Rail de glissière 150 mm
- Revêtement en PVC robuste
- Largeur du siège 510 mm
- Dossier repliable et réglable
- Contacteur de présence

OPTIONS

- Revêtement tissu noir
- Extension de dossier
- Ceinture de sécurité
- Accoudoirs
- Ceinture de sécurité





GS 20



Ce siège est adapté à tous les types de chariots élévateurs et autres petites machines. Disponible avec plusieurs options.

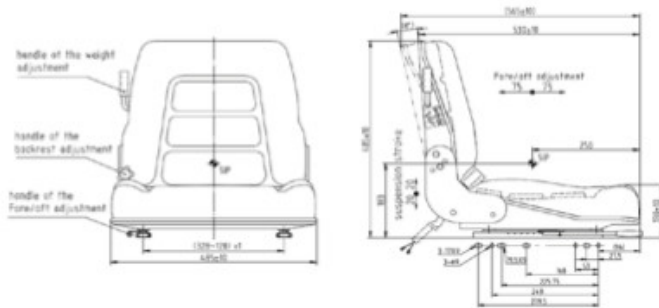

CARACTÉRISTIQUES

- Suspension mécanique
- Ajustement de poids 60-120 kg
- Course de suspension 40 mm
- Rail de glissière 150 mm
- Revêtement en PVC robuste
- Largeur du siège 490 mm
- Dossier réglable
- Contacteur de présence
- Glissière réglable en largeur de 150 mm à 328 mm

OPTIONS

- Revêtement tissu
- Ceinture de sécurité
- Accoudoirs
- Version GS12





ML 5010 Vario



Ce siège est adapté à tous les types de machines agricoles.
Disponible avec plusieurs options avec ajustement variable.

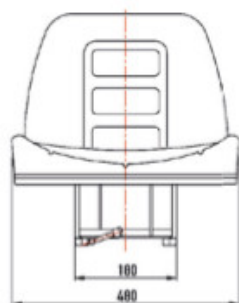
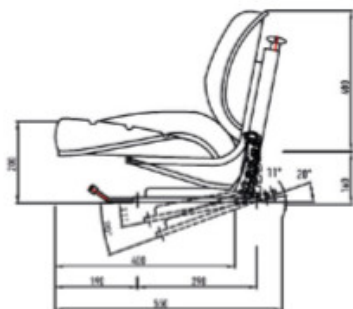

CARACTÉRISTIQUES

- Suspension mécanique sur piétement arrière
- Ajustement de poids 50-130 kg
- Course de suspension 90 mm
- Rail de glissière 170 mm
- Revêtement en PVC robuste noir
- Largeur du siège 480 mm
- Réglage Vario
- Glissière réglable en largeur de 150 mm à 328 mm

OPTIONS

- Revêtement tissu
- Extension de dossier
- Ceinture de sécurité
- Accoudoirs
- Version étroite de 390 mm de large

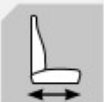



ML 4010



Ce siège est adapté à tous les types de machines agricoles.
Disponible avec plusieurs options.

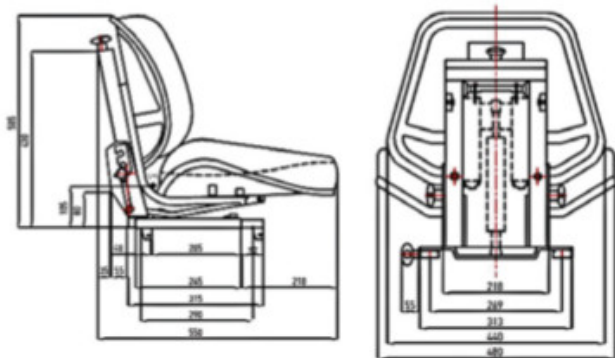

CARACTÉRISTIQUES

- Suspension mécanique basse sur piétement arrière
- Ajustement de poids 50-130 kg
- Hauteur du siège seulement 120 mm
- Course de suspension 60 mm
- Rail de glissière 170 mm
- Revêtement en PVC robuste noir
- Largeur du siège 480 mm

OPTIONS

- Revêtement tissu
- Extension de dossier
- Ceinture de sécurité
- Accoudoirs
- Version étroite de 390 mm de large

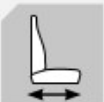



T 600



Ce siège est adapté à tous les types de machines agricoles et autres petites machines. Disponible avec plusieurs options.

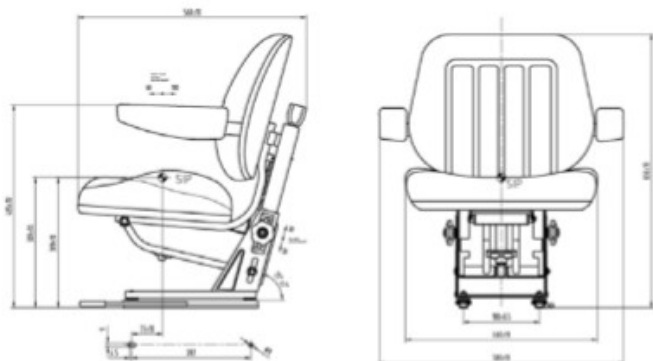

CARACTÉRISTIQUES

- Suspension mécanique sur piétement arrière
- Ajustement de poids 50-120 kg
- Course de suspension 80 mm
- Rail de glissière 160 mm
- Revêtement en PVC robuste
- Largeur du siège 460 mm
- Réglage de hauteur 60 mm
- Ceinture de sécurité
- Accoudoirs

OPTIONS

- Revêtement tissu
- Contacteur de présence





5010 MMF



Ce siège est adapté à tous les types de machines agricoles.
Disponible avec plusieurs options.

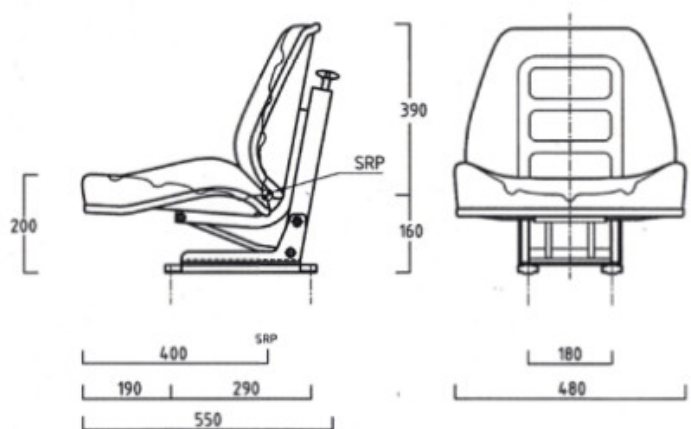

CARACTÉRISTIQUES

- Suspension mécanique sur piétement arrière
- Ajustement de poids 50-120 kg
- Course de suspension 90 mm
- Revêtement en PVC robuste
- Largeur du siège 480 mm

OPTIONS

- Ceinture de sécurité
- Accoudoirs
- Extension de dossier
- Revêtement tissu
- Version étroite 390 mm de large

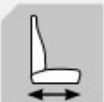



W 700



Ce siège est adapté à tous les types de machines agricoles et autres petites machines. Disponible avec plusieurs options.

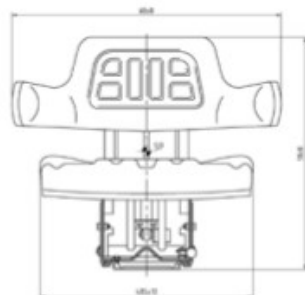
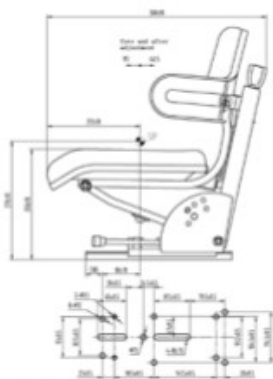

CARACTÉRISTIQUES

- Suspension mécanique sur piétement arrière
- Ajustement de poids 50-120 kg
- Course de suspension 80 mm
- Rail de glissière 150 mm
- Revêtement en PVC robuste noir
- Largeur du siège 485 mm
- Coussin de dossier avec accoudoirs intégrés
- Point de fixation pour ceinture de sécurité
- Plaque de montage réglable Vario

OPTIONS

- Ceinture de sécurité
- Coloris disponibles PVC jaune ou bleu

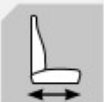



T 700



Ce siège est adapté à tous les types de machines agricoles et autres petites machines. Disponible avec plusieurs options.

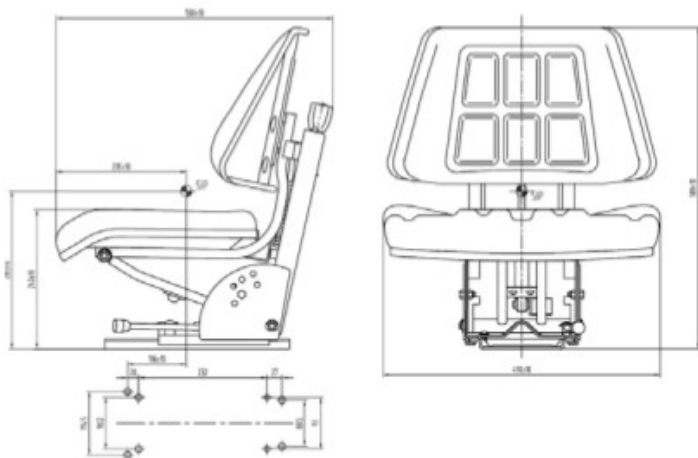

CARACTÉRISTIQUES

- Suspension mécanique sur piétement arrière
- Ajustement de poids 50-120 kg
- Course de suspension 80 mm
- Rail de glissière 150 mm
- Revêtement en PVC robuste noir
- Largeur du siège 485 mm
- Point de fixation pour ceinture de sécurité
- Coussin de dossier plat
- Plaque de montage réglable Vario

OPTIONS

- Ceinture de sécurité

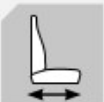



Accoudoirs de luxe



Accoudoirs réglables



Accoudoirs standard



Pod pour joystick



Ceintures statiques



Ceintures à enrouleur ALR



Ceintures avec contacteur



Votre logo





Protection de siège



Plaque tournante

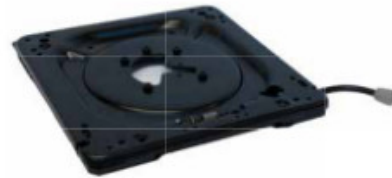

Contacteur de présence



Contacteur delta



Porte documents



Suspension horizontale



Élément chauffant



Signalisation





UNITEDSEATS

Distributeur officiel



**SEATING PRO
CONCEPT**

*Nous assemblons
votre siège*

Zone Industrielle 756 Les Cornuérèdes 83830 FIGANIERES

TEL +33 (0)4 94 70 57 18 seatingproconcept@gmail.com

www.seatingproconcept.com

retrouver-nous sur Facebook et Instagram:



Commercial Sud 06 27 04 68 53

commercial Nord 06 12 31 00 03

Sous réserve d'erreurs typographiques. Illustrations et photos non contractuelles.

NEWS
JUN 2018



New Heavy Duty suspensions



LGV120



**SEATING
PRO
CONCEPT**

LGV120 / C7

Caractéristiques

- Suspension pneumatique
- Réglage du poids 50-150 kg
- Course de suspension 100 mm
- Course de glissière 200 mm
- Revêtement de tissu UnitedSeats
- Dossier haut et réglable
- Largeur du siège de 490 mm
- Réglage d'assise en profondeur et inclinaison

Options

- Garniture en PVC robuste
- Soutien lombaire pneumatique
- Accoudoirs avec bras réglables
- Appuie-tête, Ceinture de sécurité, Contacteur de présence
- Élément chauffant 12, 24 ou 48v
- Plaque tournante, boîte à documents



MGV120 / C7 PRO

Caractéristiques

- Suspension mécanique
- Réglage du poids 50-150 kg
- Course de suspension 100 mm
- Course de glissière 200 mm
- Revêtement de tissu UnitedSeats
- Dossier haut et réglable
- Largeur du siège de 490 mm
- Réglage d'assise en profondeur et inclinaison

Options

- Garniture en PVC robuste
- Soutien lombaire pneumatique
- Accoudoirs avec bras réglables
- Appuie-tête, Ceinture de sécurité, Contacteur de présence
- Élément chauffant 12, 24 ou 48v
- Plaque tournante
- Boîte à documents



SEATING PRO CONCEPT