



CARACTÉRISTIQUES

- Entièrement en acier inoxydable
- Cuve motorisée et basculante
- Quatre roulettes
- Deux moteurs : Cuve et bras
- Machine totalement sécurisée

OPTIONS

- Bras démontable
- 4 roues pivotantes avec freins et 2 fixes

FEATURES

- Full stainless steel
- Motorized and tiltable bowl
- Four wheels
- Two motors : bowl and arm
- Machine fully secure

OPTIONS

- Removable arm
- 4 swivel wheels with brakes and 2 fixed wheels



fabricant

MÉLANGEUR VILLA M125 MEAT MIXER VILLA M125

Fiche technique / Technical sheet

Dimensions en mm

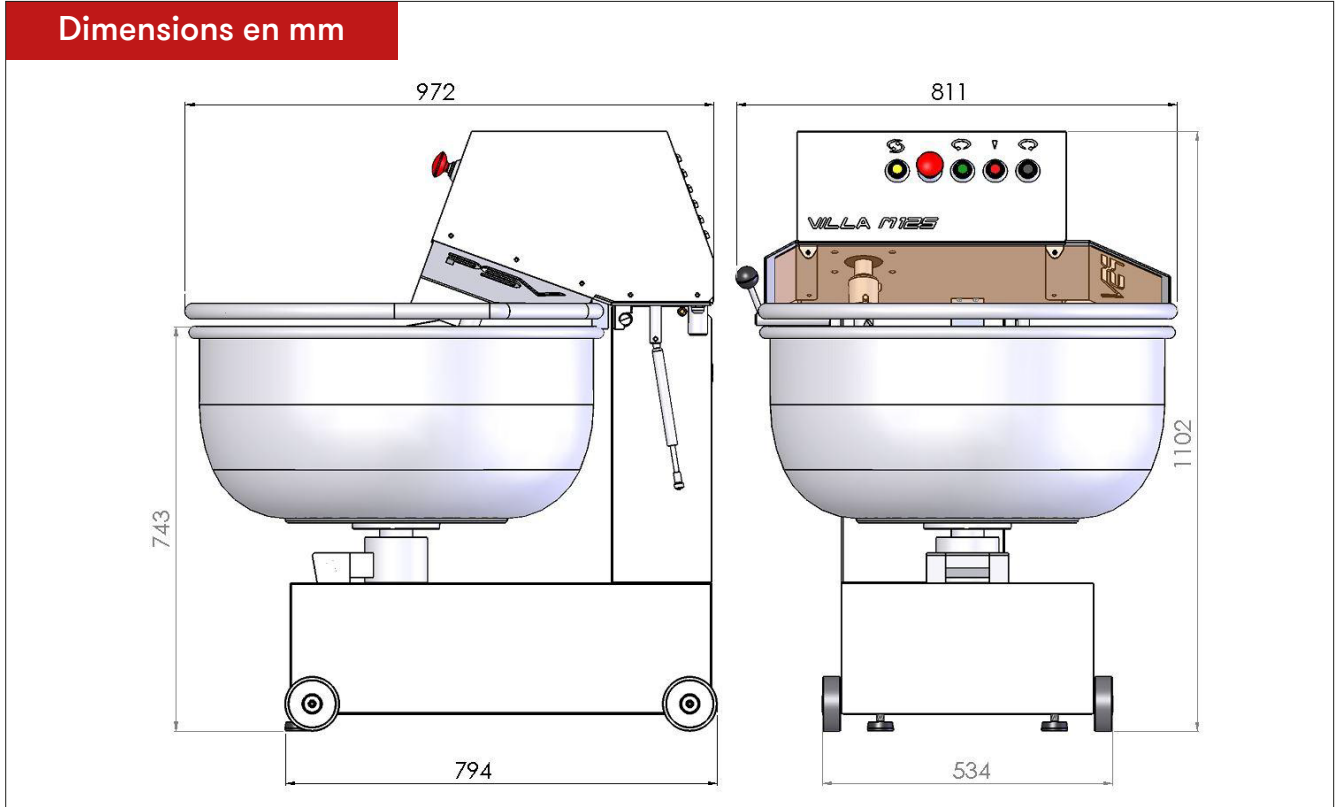

MODÈLE	ENCOMBREMENT (MM)	COLISAGE (MM)	POIDS (KG)	CAPACITÉ (L)	DIMENSIONS DE LA CUVE (MM)	PUISSANCE MOTEUR DE CUVE ET DE BRAS	VITESSE DE ROTATION BRAS ET CUVE (RPM)	TENSION	QUANTITÉ DE MÉLANGE (KG)
MODEL	SIZE (MM)	PACKING DETAILS (MM)	WEIGHT (KG)	CAPACITY (L)	BOWL SIZE (MM)	BOWL MOTOR & KNIVES MOTOR POWER	ROTATION SPEED (RPM)	VOLTAGE	MIX QUANTITY (KG)
M125	972 x 811 x 1102	1000 x 850 x 1200	180	125	720 x 350	Bras/Arm : 0.75 kW Cuve/Bowl : 0.37 kW	Bras/Arm : 47 Cuve/Bowl : 9	3/380V	Mini : 11 Maxi : 70

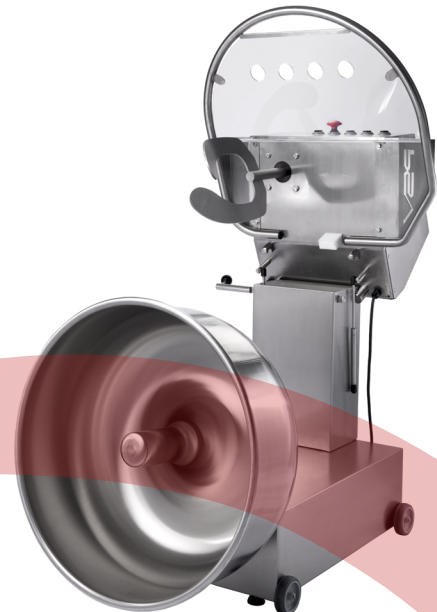

fabricant

Groupe PSV, Usine du Berre au Loup,
D147-BP20 95420 Genainville-France
www.psv-groupe.com