

CARACTERISTICAS / FEATURES

Material hormigón Petra 1
Acabado decapado e hidrofugado
Dimensiones l. 104, a. 89, h. 84 cm
Color ver carta de colores
Fijación simplemente apoyado o mediante resina epoxi
Peso 465 Kg
Palet 120 x 120 cm

Material precast concrete Petra 1
Finish scaled and waterproofed
Dimensions l. 104, w. 89, h. 84 cm
Colour see colour catalogue
Fixing resting on the ground or with epoxy resin
Weight 465 Kg
Pallet 120 x 120 cm

diseñador / design: *Hesús Alfaro, Ana Hurtado*

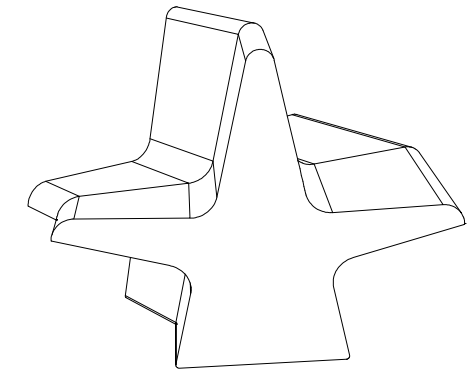
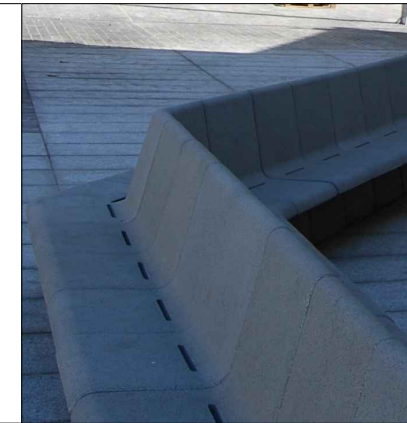

GEOMETRIA / GEOMETRY

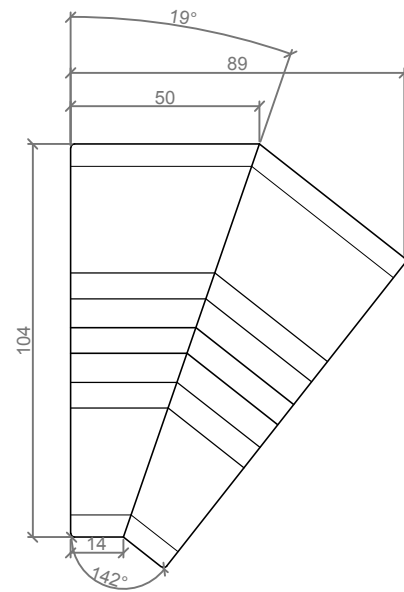

PLANTA / TOP VIEW

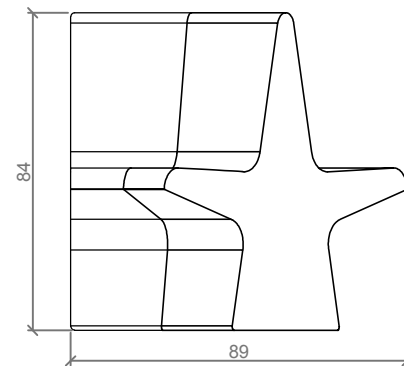

ALZADO / FRONT SIDE

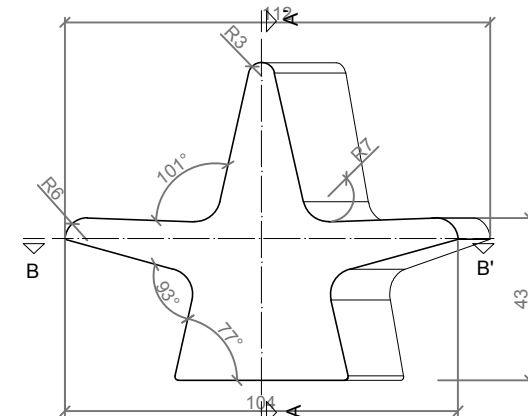

PERFIL / RIGHT SIDE

Buff'Hyères
Collectivités
 MOBILIERS & AMÉNAGEMENTS URBAIN
06 32 46 92 74 - MOBILIER@BHC83.FR

MANIPULACIÓN E INSTALACIÓN / HANDLING AND INSTALLATION

1 Elevar mediante eslingas de poliéster / Lift by polyester slings

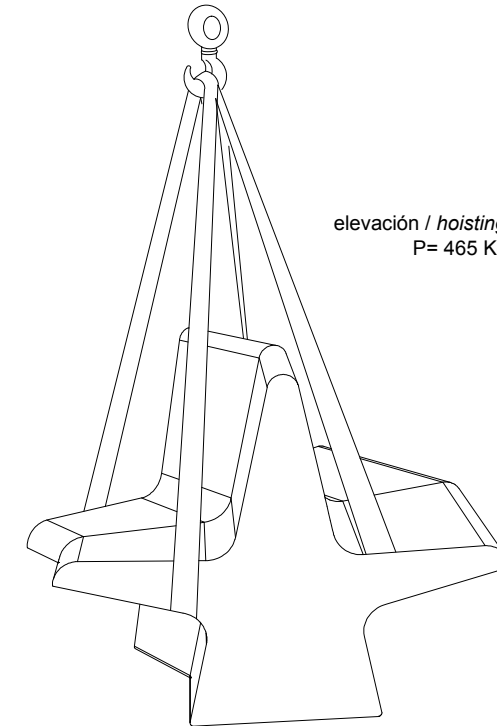

elevación / hoisting
 P= 465 Kg

2 Verter resina epoxy en el pavimento e instalar el banco / Pour epoxy resin on the pavement and install the bench

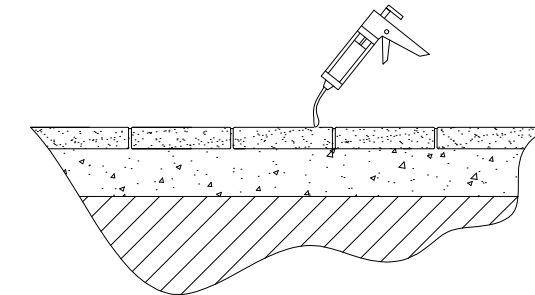

ESCALA / SCALE : 1/ 20

ESPECIFICACIONES / SPECIFICATIONS

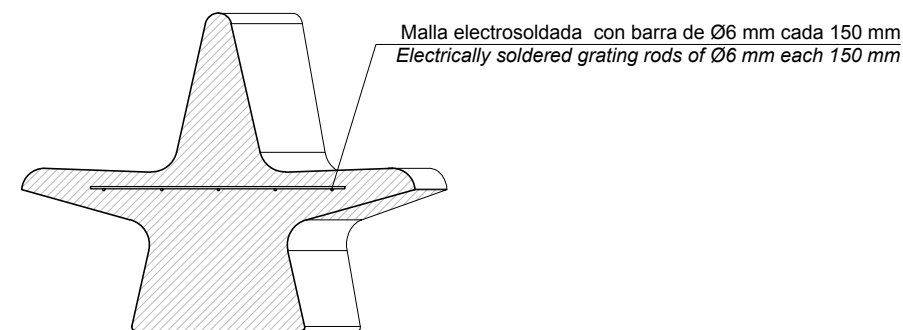

SECCIÓN / SECTION

Malla electrosoldada con barra de Ø6 mm cada 150 mm
 Electrically soldered grating rods of Ø6 mm each 150 mm

ESCALA / SCALE : 1/ 20

CARACTERÍSTICAS / FEATURES

Material hormigón Petra 1
Acabado decapado e hidrofugado
Dimensiones l. 104, a. 106, h. 84 cm
Color ver carta de colores
Fijación simplemente apoyado o mediante resina epoxi
Peso 440 Kg
Palet 120 x 120 cm

Material precast concrete Petra 1
Finish scaled and waterproofed
Dimensions l.104, w.106, h. 84 cm
Colour see colour catalogue
Fixing resting on the ground or with epoxy resin
Weight 440 Kg
Pallet 120 x 120 cm

diseñador / design: *Hesús Alfaro, Ana Hurtado*

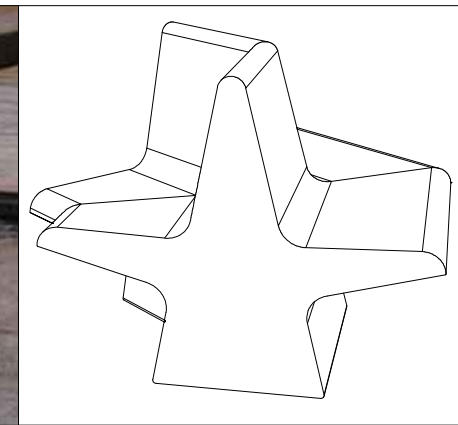

GEOMETRIA / GEOMETRY

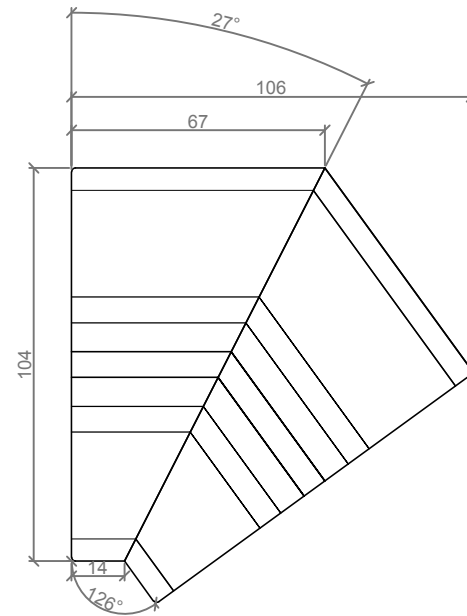

PLANTA / TOP VIEW

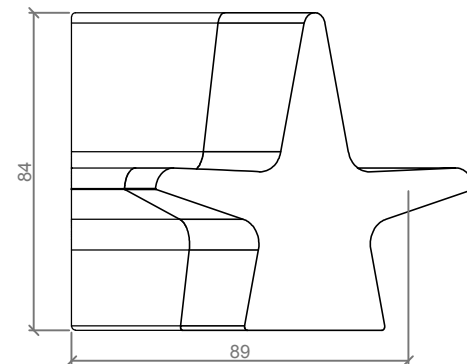

ALZADO / FRONT SIDE

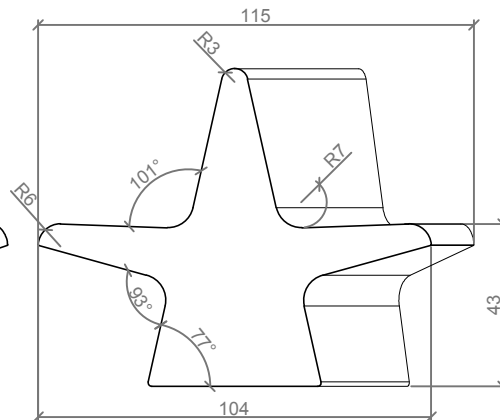

PERFIL / RIGHT SIDE

Buff'Hyères
Collectivités
 MOBILIERS & AMÉNAGEMENTS URBAIN
06 32 46 92 74 - MOBILIER@BHC83.FR

ESCALA / SCALE : 1/ 20

MANIPULACIÓN E INSTALACIÓN / HANDLING AND INSTALLATION

1 Elevar mediante eslingas de poliéster / Lift by polyester slings

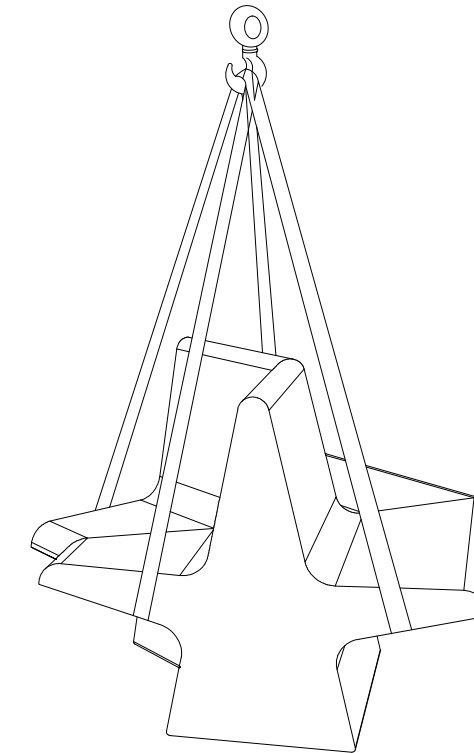

2 Verter resina epoxy en el pavimento e instalar el banco / Pour epoxy resin on the pavement and install the bench

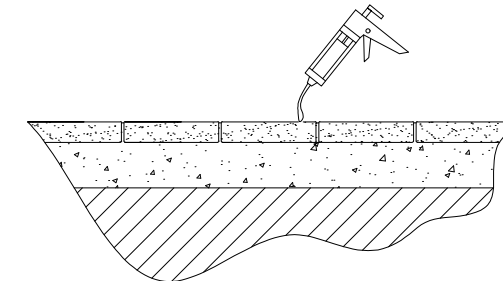

ESPECIFICACIONES / SPECIFICATIONS

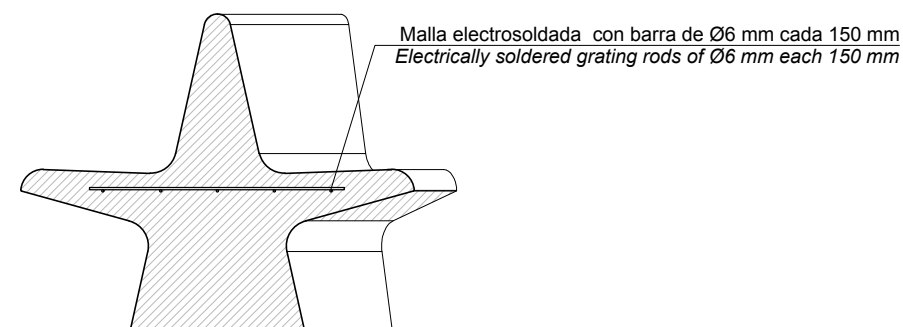

SECCIÓN / SECTION

ESCALA / SCALE : 1/ 20

CARACTERISTICAS / FEATURES

Material hormigón Petra 1
Acabado decapado e hidrofugado
Dimensiones l. 104, a. 50, h. 84 cm
Color ver carta de colores
Fijación simplemente apoyado o mediante resina epoxi
Peso 305 Kg
Palet 110 x 110 cm (2 unidades)

Material precast concrete Petra 1
Finish scaled and waterproofed
Dimensions l.104, w.50, h. 84 cm
Colour see colour catalogue
Fixing resting on the ground or with epoxy resin
Weight 305 Kg
Pallet 110 x 110 cm (2 units)

diseñador / design: *Hesús Alfaro, Ana Hurtado*

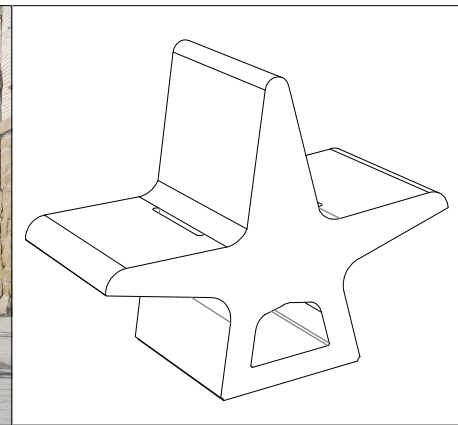

LUCER

GEOMETRIA / GEOMETRY

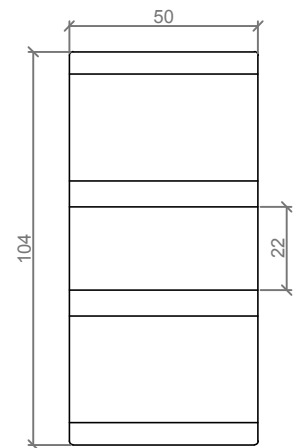

PLANTA / TOP VIEW

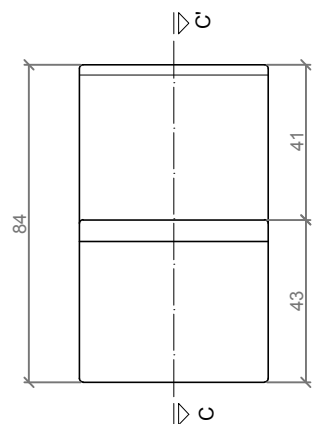

ALZADO / FRONT SIDE

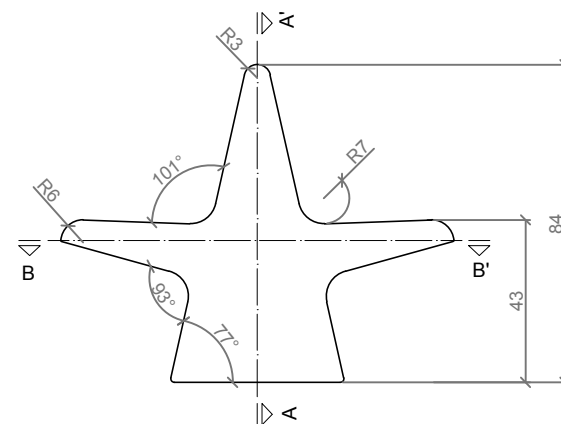

PERFIL / RIGHT SIDE

Buff'Hyères
Collectivités
 MOBILIERS & AMÉNAGEMENTS URBAIN
 06 32 46 92 74 - MOBILIER@BHC83.FR

ESCALA / SCALE : 1/ 20

MANIPULACIÓN E INSTALACIÓN / HANDLING AND INSTALLATION

1 Elevar mediante eslingas de poliéster / Lift by polyester slings

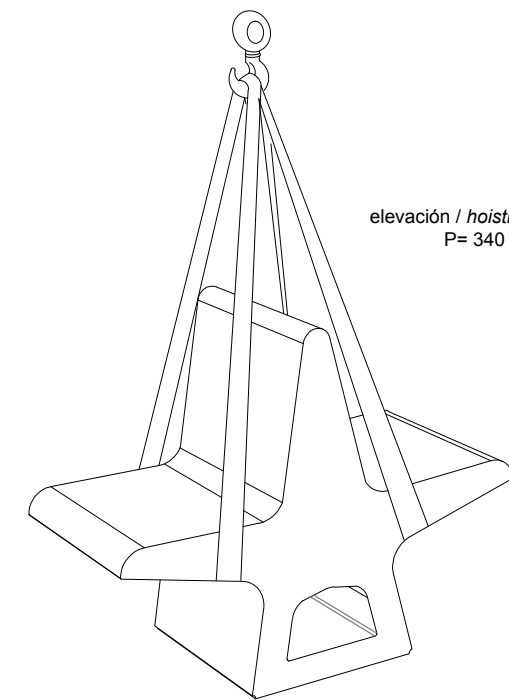

elevación / hoisting
 P= 340 Kg

2 Verter resina epoxy en el pavimento e instalar el banco / Pour epoxy resin on the pavement and install the bench

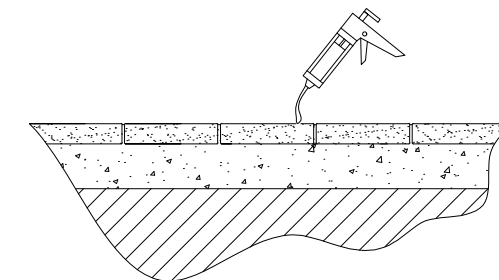

ESPECIFICACIONES / SPECIFICATIONS

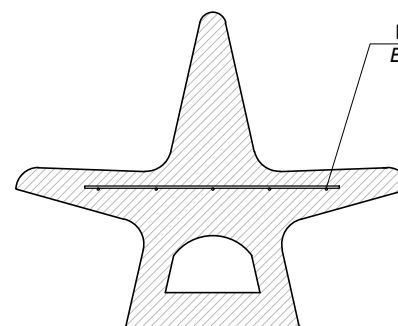

SECCIÓN / SECTION

Malla electrosoldada con barra de Ø6 mm cada 150 mm
 Electrically soldered grating rods of Ø6 mm each 150 mm

ESCALA / SCALE : 1/ 20

CARACTERÍSTICAS / FEATURES

Material hormigón Petra 1
Acabado decapado e hidrofugado
Dimensiones l. 104, a. 50, h. 84 cm
Color ver carta de colores
Fijación simplemente apoyado o mediante resina epoxi
Peso 340 Kg
Palet 110 x 110 cm (2 unidades)

Material precast concrete Petra 1
Finish scaled and waterproofed
Dimensions l.104, w.50, h. 84 cm
Colour see colour catalogue
Fixing resting on the ground or with epoxy resin
Weight 340 Kg
Pallet 110 x 110 cm (2 units)

diseñador / design: *Hesús Alfaro, Ana Hurtado*

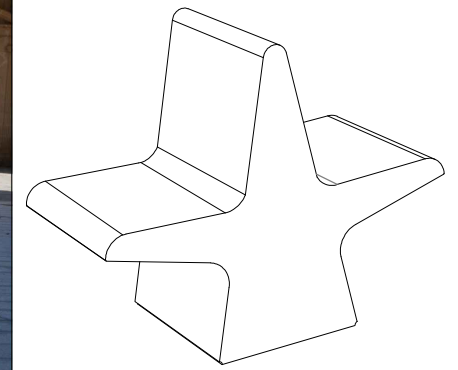

LUCE

GEOMETRIA / GEOMETRY

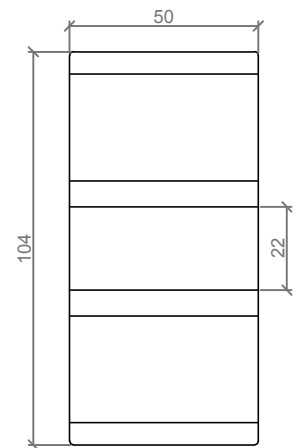

PLANTA / TOP VIEW

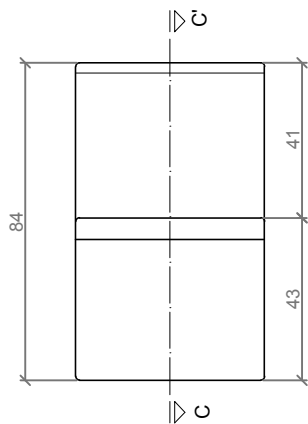

ALZADO / FRONT SIDE

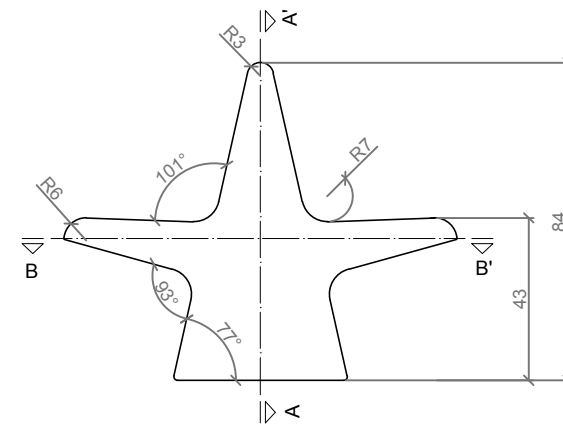

PERFIL / RIGHT SIDE

Buff'Hyères
Collectivités
 MOBILIERS & AMÉNAGEMENTS URBAIN
06 32 46 92 74 - MOBILIER@BHC83.FR

ESCALA / SCALE : 1/ 20

MANIPULACIÓN E INSTALACIÓN / HANDLING AND INSTALLATION

1 Elevar mediante eslingas de poliéster / Lift by polyester slings

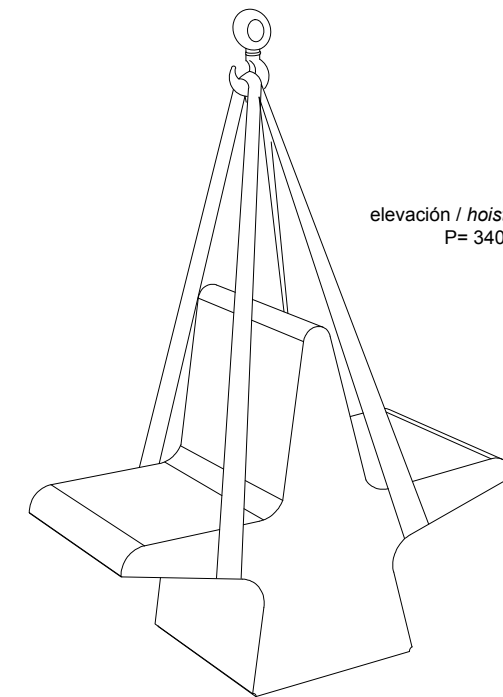

elevación / hoisting
 P= 340 Kg

2 Verter resina epoxy en el pavimento e instalar el banco / Pour epoxy resin on the pavement and install the bench

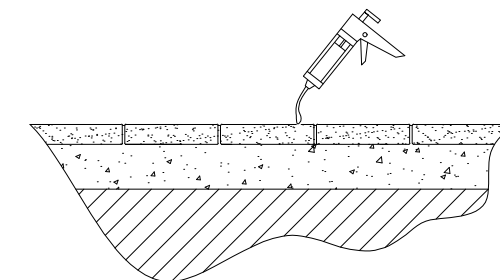

ESPECIFICACIONES / SPECIFICATIONS

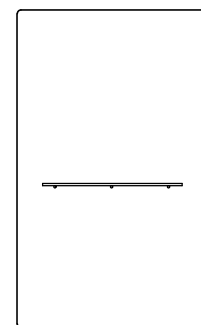

SECCIÓN / SECTION: A-A'

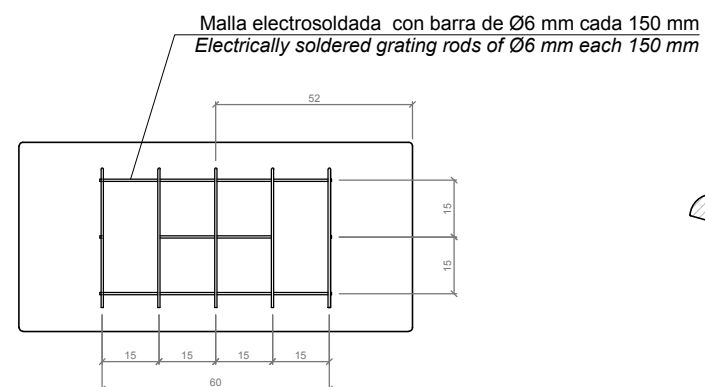

SECCIÓN / SECTION: B-B'

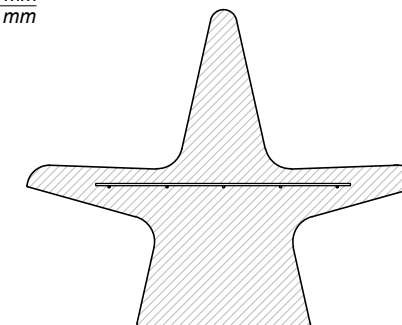

SECCIÓN / SECTION: C-C'

ESCALA / SCALE : 1/ 20

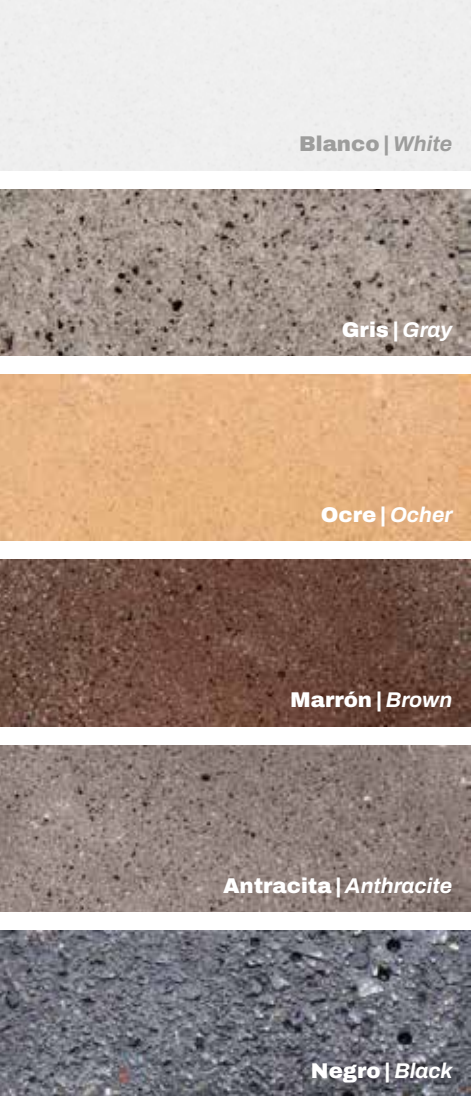

Blanco | White

Gris | Gray

Ocre | Ocher

Marrón | Brown

Antracita | Anthracite

Negro | Black

colores | colours



Amarillo | Yellow

Naranja | Orange

Rojo | Red

Azul | Blue

Verde | Green

colores opcionales (más colores disponibles)
optional colours (more available colours)

Petra 1

Personalizable
Customisable

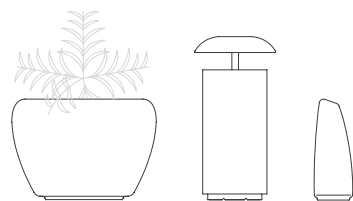
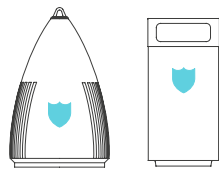

acabados de superficie

Disponibles en:
jardineras, recogida de residuos y límites

surface finishes

Available:
planters, waste collection and bollards



Corten



Negro Grafito | Black Graphite

SMC (UHPC)

acabado liso + antigraffiti

smooth finish + antigraffiti

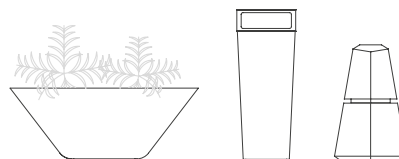

acabados de superficie

Disponibles en:
jardineras, recogida de residuos y límites

surface finishes

Available:
planters, waste collection and bollards



Corten



Golden



Bronce | Bronze



Negro Grafito | Black Graphite

colores | colours

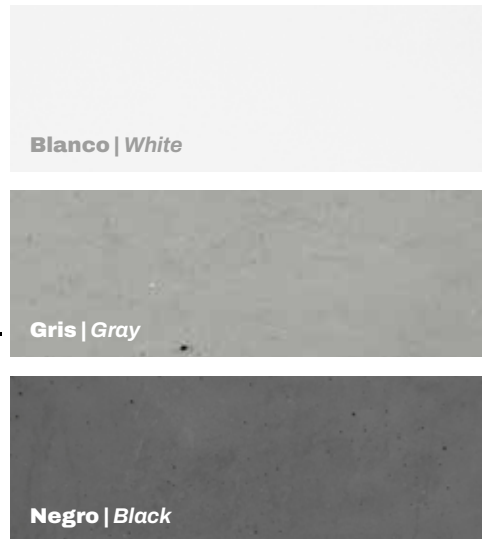

Blanco | White

Gris | Gray

Negro | Black

Buff'Hyères
Collectivités

MOBILIERS & AMÉNAGEMENTS URBAIN

06 32 46 92 74 - MOBILIER@BHC83.FR