

# N 922 STAINLESS STEEL IP 54 SERIES VACUUM PUMPS AND COMPRESSORS



N 922 STE IP 54

## ADVANTAGES

- High operating pressure of max. 6 bar rel.
- High level of gas tightness:  $6 \times 10^{-3}$  mbar x l/s according to type examination
- Dynamically adjustable to the customers' system by using the 3-phase motor in combination with a frequency converter
- Can be used for media and ambient temperatures of up to +60 °C
- Compressor housing can be turned in 90° intervals as required

## POSSIBLE AREAS OF USE

- Environmental monitoring
- Process industry
- Chemical industry

Please visit our website  
[www.knf.com](http://www.knf.com)  
to get more information

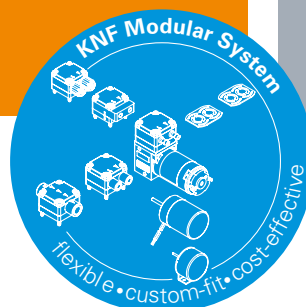

## PERFORMANCE DATA

Series model	N 922 IP 54 - 50 Hz Version			N 922 IP 54 - 60 Hz Version	
	STE	SPE		STE	SPE
Pump head	Stainless steel			Stainless steel	
Diaphragm	PTFE-coated	EPDM		PTFE-coated	EPDM
Valves	Stainless steel			Stainless steel	
Flow rate at atm. pressure (l/min)	21.0 ± 10 %	22.0 ± 10 %		24.0 ± 10 %	25.0 ± 10 %
Ultimate vacuum (mbar abs.)	110			110	
Max. operating pressure (bar rel./psig)	4.0/58.0 6.0/87.0 intermittent			4.0/58.0 6.0/87.0 intermittent	
Permissible ambient temperature (°C)	+5 ... +60 – 0 if frost-free (non-condensing)			+5 ... +60 – 0 if frost-free (non-condensing)	
Permissible media temperature (°C)	0 ... +60			0 ... +60	
Weight (kg/lbs)	8.3/18.3			8.3/18.3	

## ELECTRICAL DATA

Voltage (V)	230	100	115	220	230/400
Motor	Capacitor motor				Three-phase motor
Protection class motor	IP 54				
Protection class pump	IP 54				
Frequency (Hz)	50	50/60	60		50/60
Power P <sub>1</sub> , 50 Hz (W)	130	120	-		205
Power P <sub>1</sub> , 60 Hz (W)	-	185	210	180	145
I <sub>max</sub> (A), 50 Hz	0.65	1.25	-		1.4/0.8
I <sub>max</sub> (A), 60 Hz	-	1.9		0.9	0.95/0.55

# N 922 STE | CAPACITOR MOTOR

## PERFORMANCE DATA

Series model	Flow rate at atm. pressure (l/min) <sup>1)</sup>	Max. operating pressure (bar rel./psig)	Ultimate vacuum (mbar abs.)
N 922 STE- 50 Hz	21.0 ± 10 %	6.0/87.0	110
N 922 STE- 60 Hz	24.0 ± 10 %	6.0/87.0	110

<sup>1)</sup> Flow rate determined at 20 °C, 1013 mbar abs.  
(Pressure 0 to 1013 mbar abs. in accordance with ISO 21360-1/2)

## N 922 STE

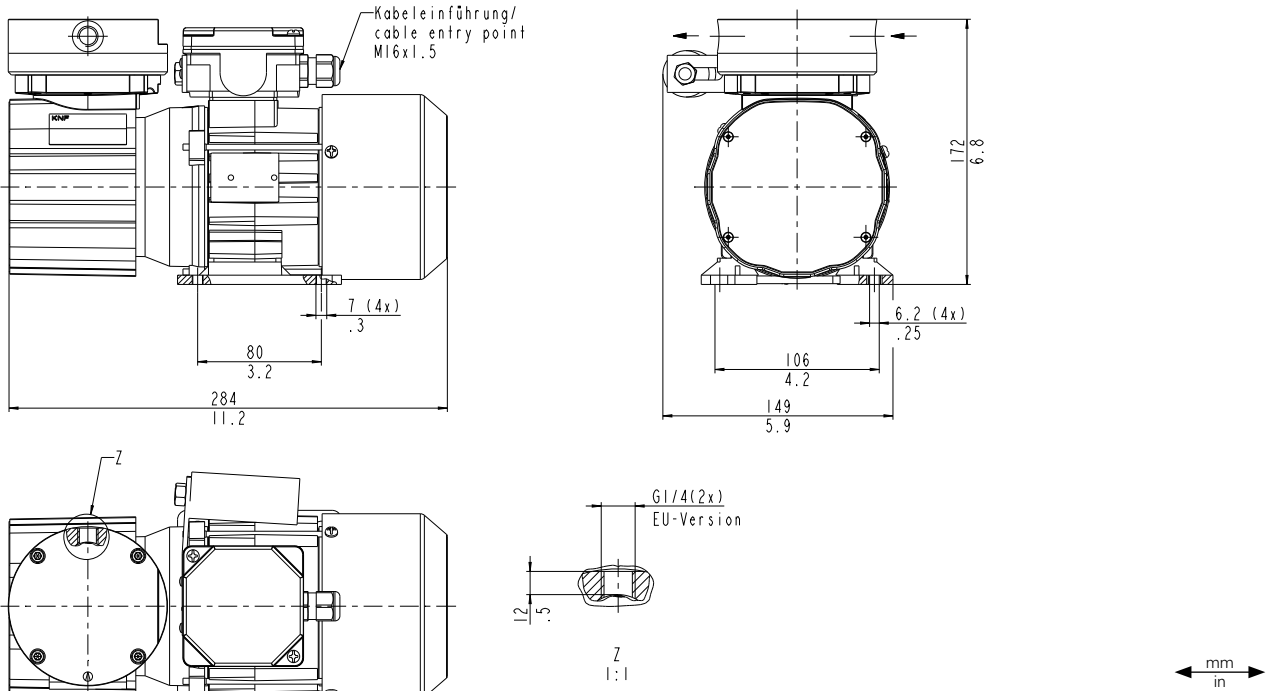

## N 922 STE

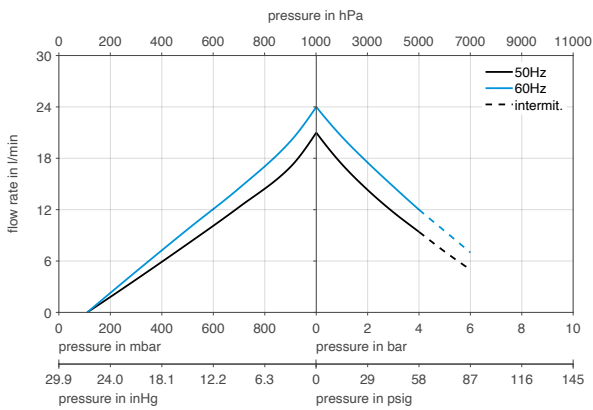

## N 922 STE | PUMP UPTIME FOR 20 LITER VESSEL

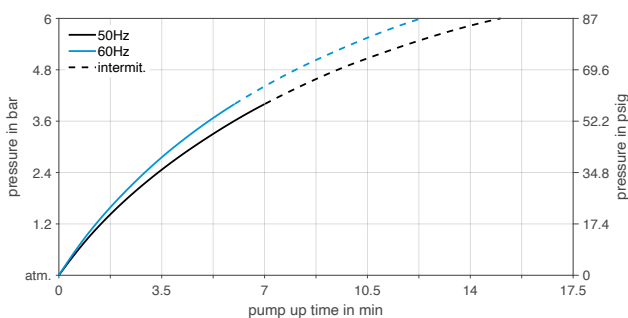

## N 922 STE | PUMP DOWNTIME FOR 20 LITER VESSEL

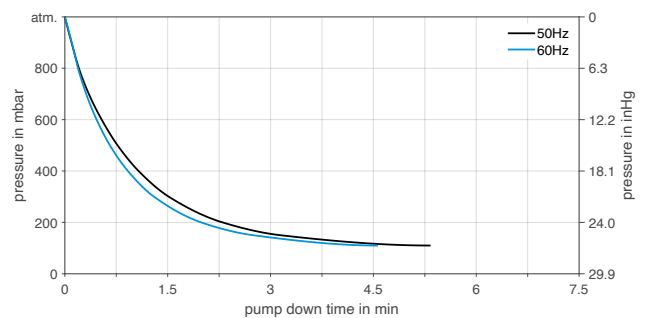

# N 922 STE | THREE-PHASE MOTOR

## PERFORMANCE DATA

Series model	Flow rate at atm. pressure (l/min) <sup>1)</sup>	Max. operating pressure (bar rel./psig)	Ultimate vacuum (mbar abs.)
N 922 STE- 50 Hz	21.0 ± 10 %	6.0/87.0	110
N 922 STE- 60 Hz	24.0 ± 10 %	6.0/87.0	110

<sup>1)</sup> Flow rate determined at 20 °C, 1013 mbar abs.  
(Pressure 0 to 1013 mbar abs. in accordance with ISO 21360-1/2)

## N 922 STE

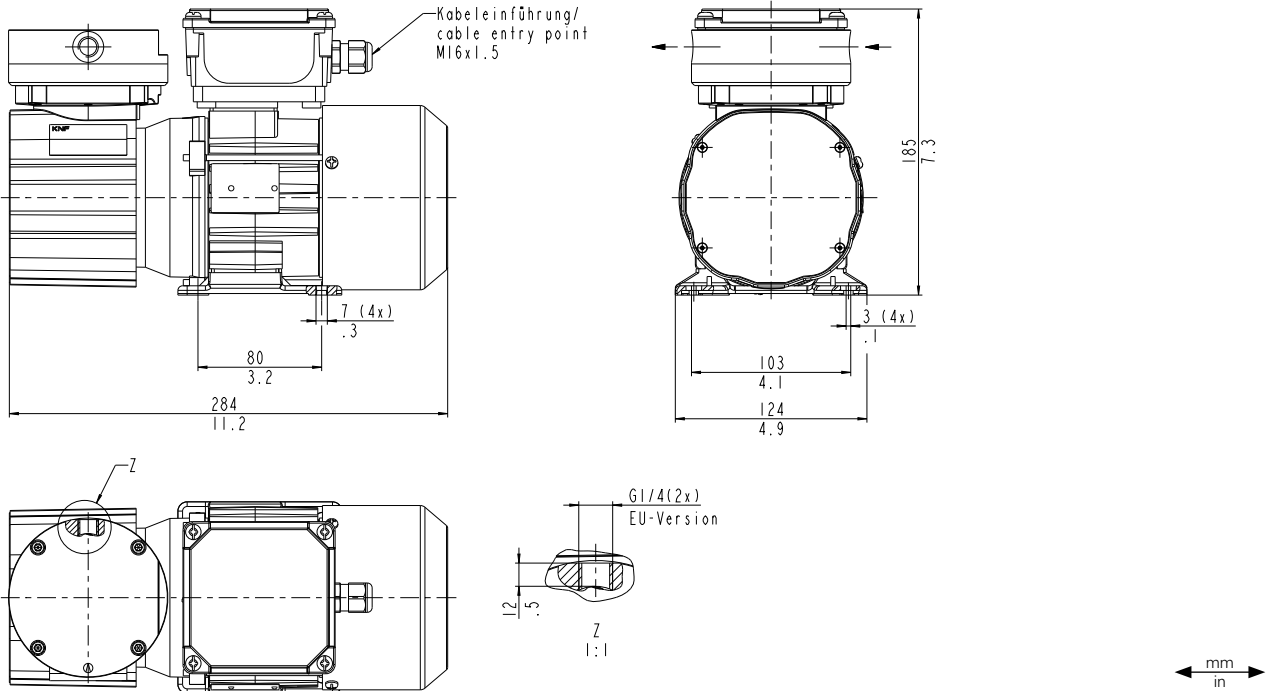

## N 922 STE

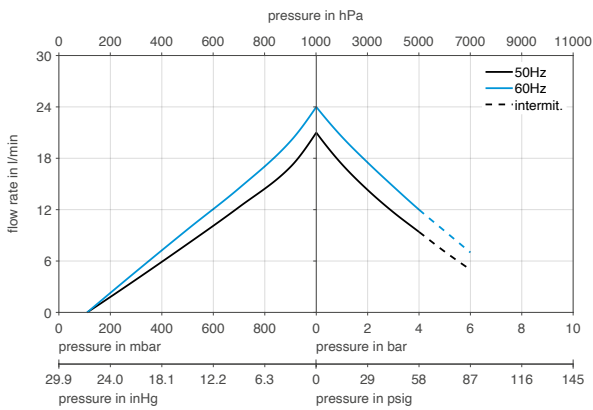

## N 922 STE | PUMP UPTIME FOR 20 LITER VESSEL

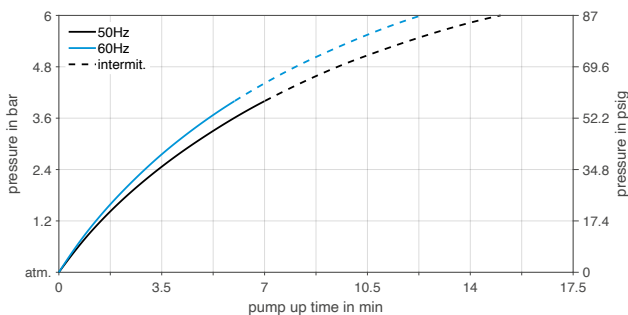

## N 922 STE | PUMP DOWNTIME FOR 20 LITER VESSEL

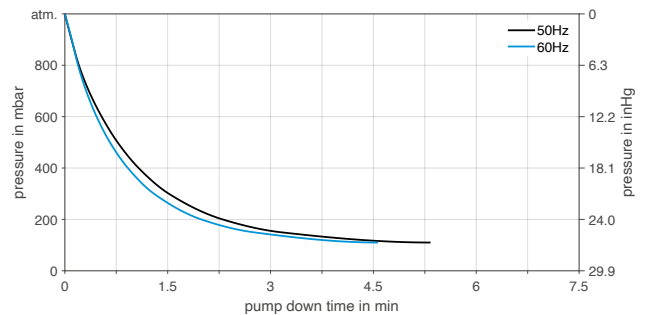

# N 922 SPE | CAPACITOR MOTOR

## PERFORMANCE DATA

Series model	Flow rate at atm. pressure (l/min) <sup>1)</sup>	Max. operating pressure (bar rel./psig)	Ultimate vacuum (mbar abs.)
N 922 SPE- 50 Hz	22.0 ± 10 %	6.0/87.0	110
N 922 SPE- 60 Hz	25.0 ± 10 %	6.0/87.0	110

<sup>1)</sup> Flow rate determined at 20 °C, 1013 mbar abs.  
(Pressure 0 to 1013 mbar abs. in accordance with ISO 21360-1/2)

## N 922 SPE

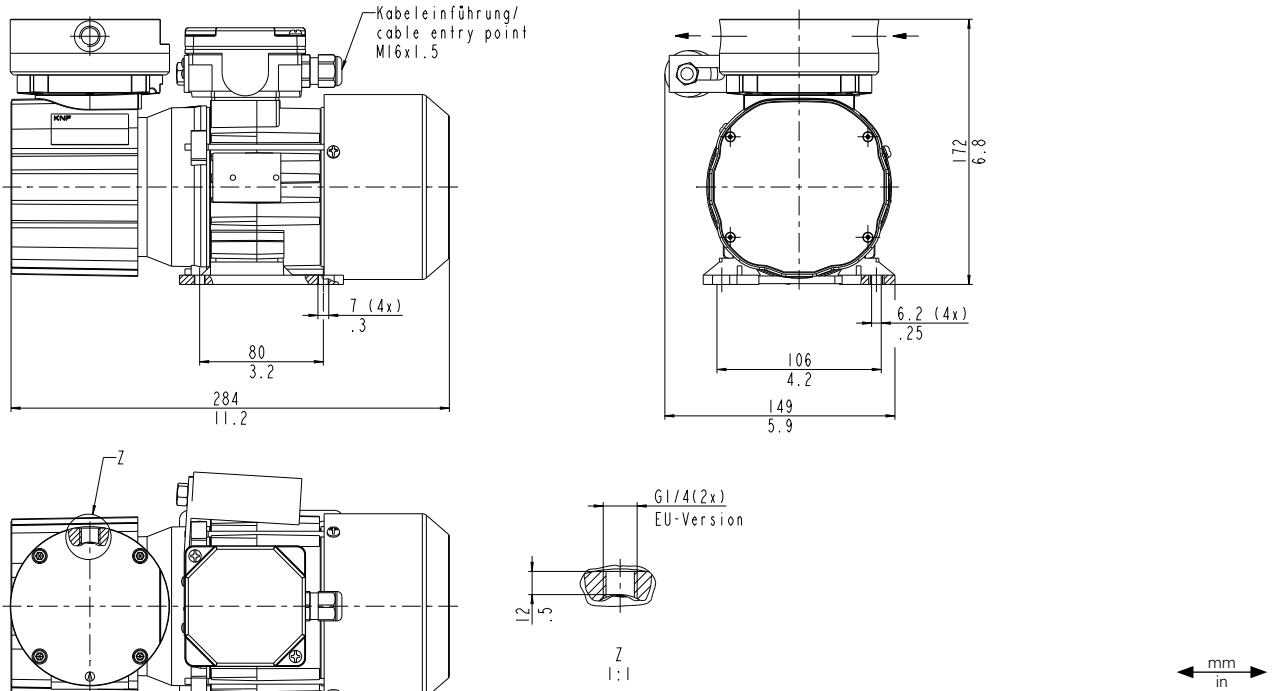

## N 922 SPE

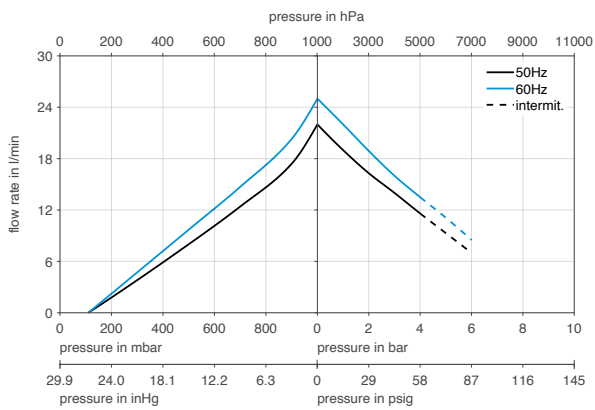

## N 922 SPE | PUMP UP TIME FOR 20 LITER VESSEL

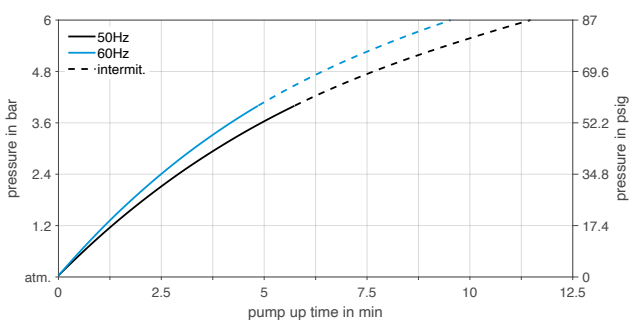

## N 922 SPE | PUMP DOWN TIME FOR 20 LITER VESSEL

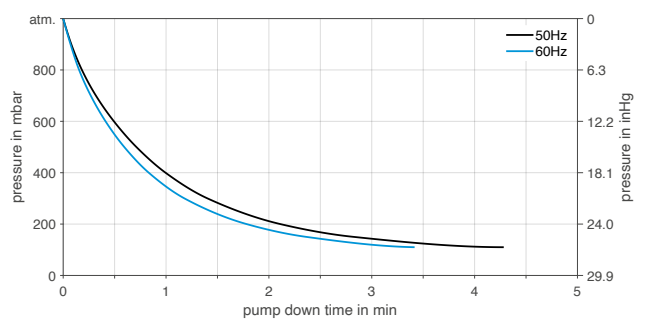

# N 922 SPE | THREE-PHASE MOTOR

## PERFORMANCE DATA

Series model	Flow rate at atm. pressure (l/min) <sup>1)</sup>	Max. operating pressure (bar rel./psig)	Ultimate vacuum (mbar abs.)
N 922 SPE- 50 Hz	22.0 ± 10 %	6.0/87.0	110
N 922 SPE- 60 Hz	25.0 ± 10 %	6.0/87.0	110

<sup>1)</sup> Flow rate determined at 20 °C, 1013 mbar abs.  
(Pressure 0 to 1013 mbar abs. in accordance with ISO 21360-1/2)

## N 922 SPE

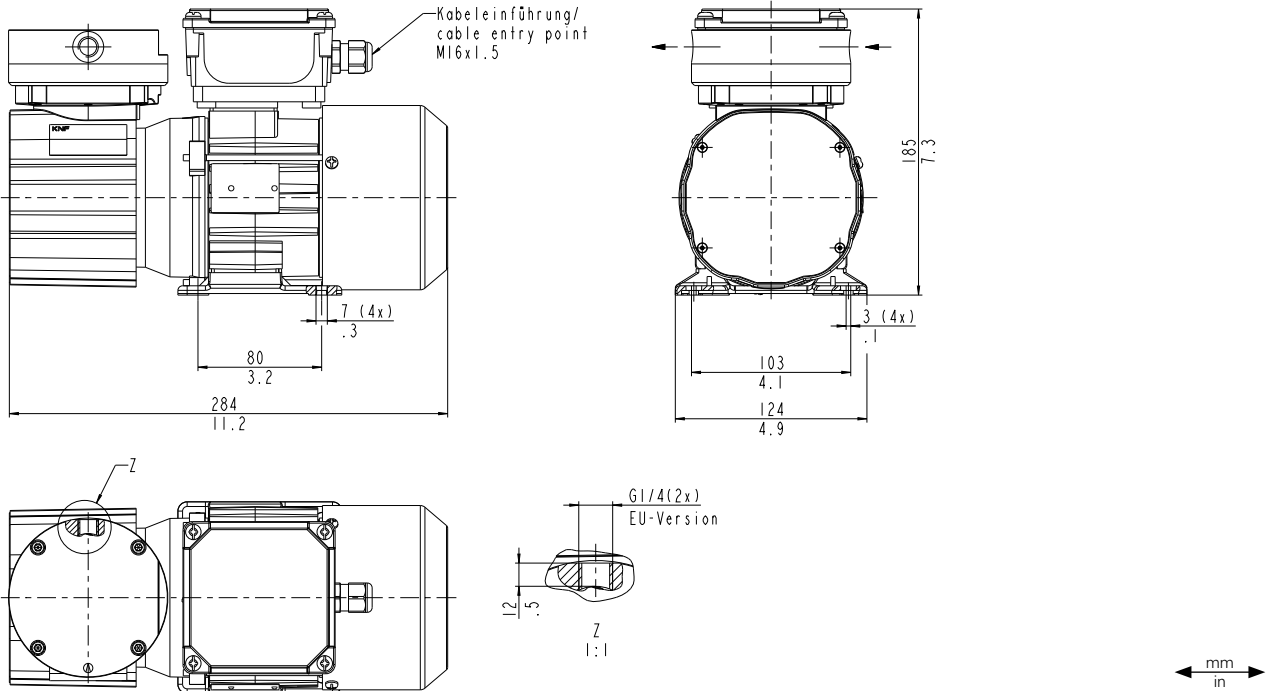

## N 922 SPE

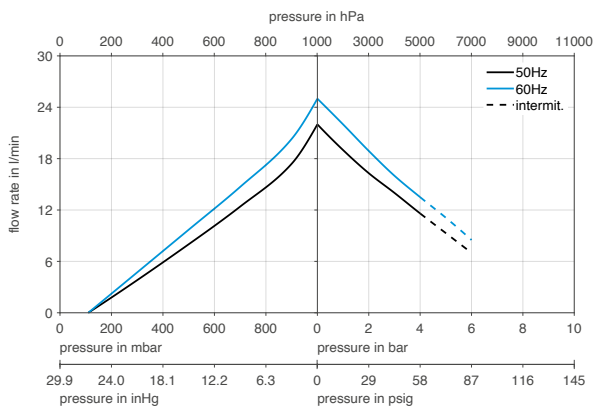

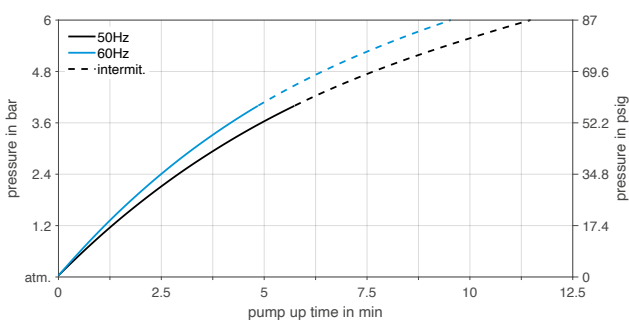

## N 922 SPE | PUMP UP TIME FOR 20 LITER VESSEL

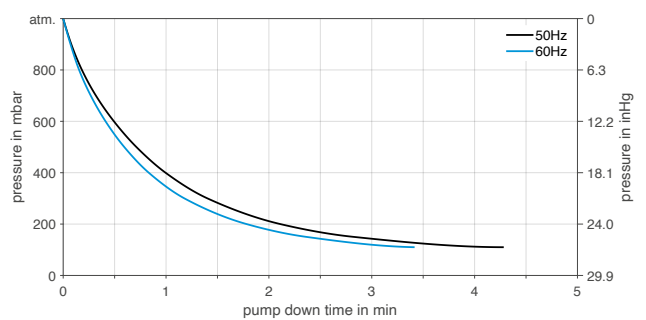

## N 922 SPE | PUMP DOWN TIME FOR 20 LITER VESSEL

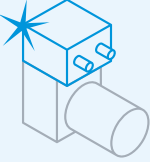

## OPTIONS

Description	Illustration	Details
Mechanical adjustment of pumping capacity		The pumping capacity can be adjusted at the factory to accommodate inlet pressure and for accurate alignment with the customer's system.
Pump housing can be rotated at 90° intervals		Pumps with a pump housing rotated at 90° intervals can be mounted at the factory. The customer may also rotate the pump housing later.
Pump with mounting bracket		The mounting bracket can be mounted at the factory.
Cleaned contact material parts		For the use of the pump with gases with high oxygen concentrations the parts that come into contact with the medium can be cleaned (including cleaning protocol).
Silcotec coating		The head components may be coated with SilcoTek™.

## ACCESSORIES

Description	Illustration	Part No.	Details
Straight compression fitting OD 10		317086	Stainless steel, G 1/4
Elbow compression fitting OD 10		318946	Stainless steel, G 1/4
Mounting kit shock mounts		313180	

## SPARE PARTS

Description	Illustration	Part No.	Details
Spare parts kit N 922 STE		328447	Spare parts kit consists of: 1x diaphragm, 2x reed valve, 2x valve stopper, 2x screw, 3x O-ring. This set is required to maintain the pump.
Spare parts kit N 922 SPE		331313	Spare parts kit consists of: 1x diaphragm, 2x reed valve, 2x valve stopper, 2x screw, 3x O-ring. This set is required to maintain the pump.

The performance values for the series models shown on this data sheet were determined under test conditions. The actual performance values may differ and depend in particular on the usage conditions and therefore on the specific application, on the parameters of the components involved in the user's system and on any technical modifications carried out which deviate from the standard configuration or the as delivered condition.

If individual designs have been created for specific customers on the basis of series models, other technical performance data may apply. Before operation begins, the relevant operating instructions and/or assembly or installation instructions should be read and the safety information contained in these instructions should be noted. KNF reserves the right to make changes to the product and the associated documentation without prior notice to the customer.



[www.knf.com](http://www.knf.com)