



# Bobcat®

COMPACT LOADERS

S450



***One Tough Animal™***

## COMPACT, COMFORT AND CONTROL

Picture the acclaimed cab of the 500 series loaders on this compact machine. For the first time in this class, large machine comfort and technology are built into a compact: for greater operator space, comfort and control.

- New cab-forward design gives you greater visibility and safety.
- Largest cab door on this size of machine.
- HVAC and pressurized cab as a first on a machine of this size.



### Performance and Control

- Redesigned hydraulic and transmission systems for improved productivity.
- New lift arm design for flatter lift curve and use of dual tilt cylinders.
- Optional Selectable Joystick controls have operator seat mounted joysticks for increased control and comfort. Plus, 2-speed option for faster travel speed.



### Uptime

- New frame and lift arms for greater durability in heavy-duty applications.
- Integrated rear bumper extends beyond the frame to protect the tailgate.
- **Long-life hydraulic oil filter extends service intervals.**
- Automatic drive belt tensioner.



### Serviceability

Improvements to key service components:

- Battery access and fuse box.
- Air filter access and cover.
- Hydraulic tank level and filters.
- Easy clean cooling package.
- Simplified grease points.

# S450 — SPECIFICATIONS

## MACHINE RATING

	<b>S450</b>
Rated operating capacity (Bobcat)	608 kg
Tipping load	1215 kg
Pump capacity	64.00 L/min
System relief at quick couplers	22.4-23.1 MPa
Max. travel speed (high range - option)	14.8 km/h
Max. travel speed (low range)	11.4 km/h

## ENGINE

Make / Model	Kubota / V2203-M-DI-E2B-BC-3
Fuel	Diesel
Cooling	Liquid
Power at 2400 RPM	36.4 kW
Torque at 1425 RPM (SAE J1 995 Gross)	150.0 Nm
Number of cylinders	4
Displacement	2196 cm <sup>3</sup>
Fuel tank	54.50 L

## WEIGHTS

Operating weight	2240 kg
Shipping weight	2052 kg

## CONTROLS

Vehicle steering	Direction and speed controlled by two hand levers
Loader hydraulics tilt and lift	Separate foot pedals or optional Advanced Control System (ACS) or Selectable Joystick Controls (SJC)
Front auxiliary (standard)	Electrical switch on right-hand steering lever

## DRIVE SYSTEM

Transmission	Infinitely variable tandem hydrostatic piston pumps, driving two fully reversing hydrostatic motors
--------------	---

## STANDARD FEATURES

- Cushion suspension seat
- Automatically activated glow plugs
- Auxiliary hydraulics: variable flow/maximum flow
- Bob-Tach™ frame
- Bobcat Interlock Control System (BICS)
- 10 x 16.5, 10-ply, Heavy duty tyres
- Deluxe operator cab Includes interior cab foam, side, top and rear windows, Deluxe wire harness, dome light, and electrical power port<sup>1</sup>
- Electrically activated proportional front auxiliary hydraulics
- Engine/hydraulics system shutdown
- Instrumentation
- Lift arm support
- Noise reduction kit
- Operating lights, front and rear
- Parking brake
- Seat belt
- Seat bar
- Spark arrestor muffler
- CE certification
- Warranty: 12 months or 2000 hours (whichever occurs first)

1. Roll Over Protective Structure (ROPS) – meets requirements of SAE-J1040 and ISO 3471; Falling Object Protective Structure (FOPS) – meets requirements of SAE-J1043 and ISO 3449, Level I

## OPTIONS

- Deluxe instrument panel
- Power Bob-Tach™
- Cab enclosure
- Cab enclosure with heating
- Cab enclosure with HVAC
- Hydraulic bucket positioning (including ON/OFF switch)
- 10 x 16.5, 10-ply, Severe duty tyres
- 10 x 16.5, 12-ply, Severe duty tyres, poly filled
- 10 x 16.5, Solid Flex tyres
- Advanced Control System (ACS)
- Selectable Joystick Controls (SJC)
- Air ride seat with 2 point seat belt
- Radio
- Strobe
- Back-up alarm
- Beacon

## ENVIRONMENTAL

Operator LpA(98/37 & 474-1)	87 dB(A)
Noise level LWA(EU Directive 2000/14/EC)	101 dB(A)
Whole body vibration (ISO 2631-1) High speed	1.29 ms-2
Whole body vibration uncertainty	0.52 ms-2
Hand-arm vibration (ISO 5349-1) High speed	1.73 ms-2

## DIMENSION

All dimensions in mm.

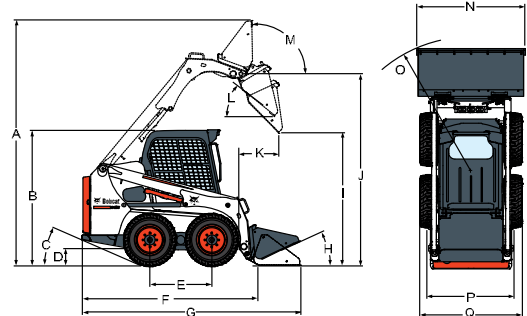

A	3558.0 mm	J	2781.0 mm
B	1976.0 mm	K	587.0 mm
C	23°	L	40°
D	214.0 mm	M	96°
E	900.0 mm	N	1575.0 mm
F	2502.0 mm	O	1940.6 mm
G	3172.0 mm	P	1221.7 mm
H	26°	Q	1490.0 mm
I	2157.0 mm		

## ATTACHMENTS

- |                                   |                               |
|-----------------------------------|-------------------------------|
| Angle Brooms                      | Planers                       |
| Augers                            | Root Grapples                 |
| Backhoes                          | Scarifiers                    |
| Bale Forks                        | Scrapers                      |
| Breakers                          | Seeders                       |
| Brush Saws                        | Skeleton Buckets              |
| Bucket Adapters                   | Snow & Light Material Buckets |
| Concrete Mixers                   | Snow Blades                   |
| Construction / Industrial Buckets | Snowblowers                   |
| Cutter Crushers                   | Snow Pushers                  |
| Diggers                           | Snow V-Blades                 |
| Dozer Blades                      | Sod Layers                    |
| Dumping Hoppers                   | Soil Conditioners             |
| Fertilizer Buckets                | Spare Wheels                  |
| Flail Cutters                     | Spreaders                     |
| General Purpose Buckets           | Stabilizers                   |
| Graders                           | Sweepers                      |
| Grapples, Industrial              | Tillers                       |
| Landplanes                        | Tilt-Tatch                    |
| Landscape Rakes                   | Tracks                        |
| Laser Equipment                   | Trenchers                     |
| Low Profile Buckets               | Utility Forks                 |
| Mowers                            | Utility Frames                |
| Packer Wheels                     | Vibratory Rollers             |
| Pallet Fork Accessories           | Water Kits                    |
| Pallet Forks, Hydraulic           | Whisker Brooms                |
| Pallet Forks, Standard            |                               |

Specifications and design are subject to change without notice. Pictures of Bobcat products may show other than standard equipment.



**Bobcat**®

www.bobcat.eu

gium

## Louer chez Duma Rent - Mini-chargeuses Location Location Mini-chargeuses BOBCAT S450

La mini-chargeuse est l'engin parfait pour tous les chargements ou déplacements de matériaux, travaux de nivellement, de remblayage et de nettoyage. La machine s'accompagne de divers accessoires adaptés tels que des brosses, fourches à palette, fourches à fumier, etc. N'hésitez pas à consulter les numéros de produits se rapportant aux éléments et accessoires souhaités. (Voir colonne de gauche)

[Louer chez Duma Rent - Lire plus](#)