



Potence de soudage avec bras horizontal .

Version avec embase fixe ou mobile sur glissière actionnée par moteur .

Structure robuste pour garantir une flexion minimum du bras

Modèles pour des hauteur jusqu'à 6 mètres

Installations électrique conforme aux normes CEI EN-60204-1

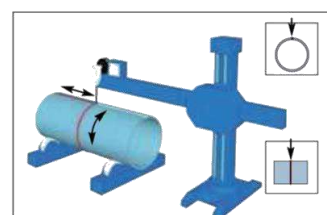

Soudure externe - axe circulaire

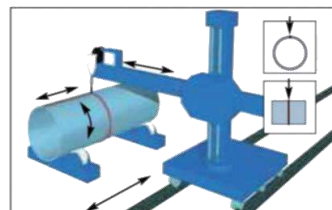

Soudure à partir d'un chariot mobile

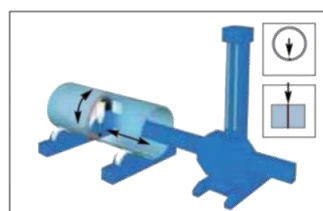

Soudure interne - axiale et circulaire

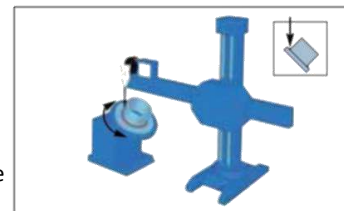

Soudure sur un positionneur à table tournante

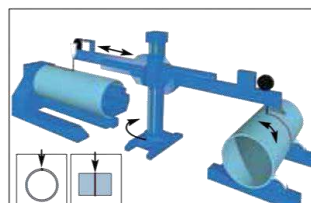

Double bras multi-soudage - soudure trépied axial

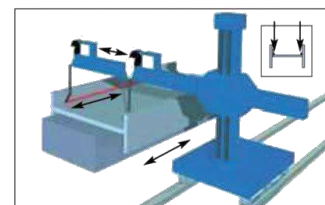

Double tête, soudure longitudinale

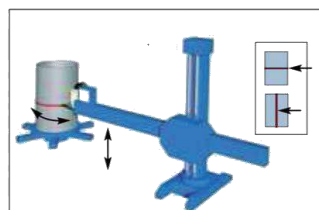

Soudure circulaire et verticale vers le bas, sur la table tournante

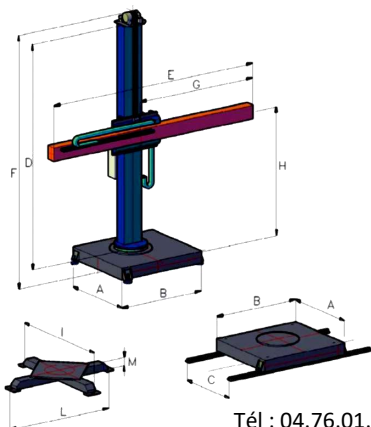

		SMB ALU 1,5x1,5	SMB 2X2	SMB 3X3	SMB 4X4	SMB 5X5	SMB 6X6
A	mm	1320	1500	1750	1800	2050	2500
B	mm	1320	1600	1900	2050	1900	2200
C	mm	- - -	1200	1550	1550	1550	1800
E	mm	2200	3000	4200	5200	7000	8100
F	mm	2760	3350	4750	5750	6800	7950
G	mm	1500	2500	3600	4600	5600	6600
H	mm	810	650	750	800	860	900
I	mm	- - -	1500	1700	2000	2200	2400
L	mm	- - -	1500	1700	2000	2200	2400
M	mm	- - -	160	200	260	280	320
↑ / ↓	mm/min	900		750		750	750
→ / ←	mm/min	1280		MIN/MAX 500/2000		500/2000	500/2000

21 rue de Sassenage – 38600 FONTAINE

Tél : 04.76.01.03.01 – [www.ecofitec.com](http://www.ecofitec.com) – [www.ecofitec-coupage.com](http://www.ecofitec-coupage.com)

info@ecofitec.com

