

CB122410A

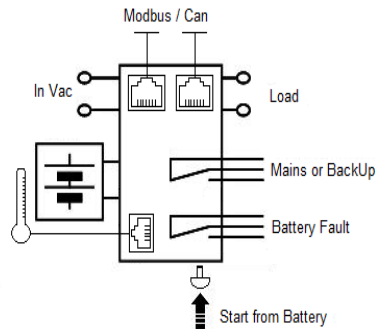

Input: Single-phase 115 - 230 - 277 Vac
Output Selectable Load: 12 Vdc 15A; 24 Vdc 10A
Output Battery charging: 12 Vdc 15A; 24 Vdc 10A
Suited for the following battery types: Open Lead Acid, Sealed Lead Acid, lead Gel and Ni-Cd
Automatic diagnostic of battery status, Battery Life Test function (internal Battery Impedance)
Charging curve IUoU, constant voltage and current
Four charging levels: Boost, Absorption, Float, Recovery
Protected against short circuit and inverted polarity
Signal output: for battery Fault, Mains or Back-Up
Modbus RTU for all parameter battery and system
Protection degree IP20; Space saving

Technical features

Power Management: Thanks to Battery Charger range, it will be possible to optimize power management. The available power is automatically allocated between load and battery, supplying power to the load is the first priority of the unit thus it is not necessary to double the power, because also the power going to the battery will go to the load if the load so requires. The maximum available current on the load output is 3 times the value of the device rated current I_n .

Battery Care: it's the concept base on algorithms that implement rapid and automatic charging, four state of charge, battery charge optimization during time, flat batteries recovery and real time diagnostic during installation and operation. The Real Time Auto-diagnostic system, monitoring battery faults such as, battery Sulfated, elements in short circuit, accidental reverse polarity connection, disconnection of the battery, they can easily be detected and removed by help of Blink Code of Diagnosis Led; during the installation and after sell. The continuous monitoring of battery efficiency, reduces battery damage risk and allows a safe operation in permanent connection. Each device is suited for all battery types, by means of jumpers it is possible setting predefined curves for Open Lead Acid, Sealed Lead Acid, Gel, Ni-Cd(option). They are programmed for two charging levels, boost and float, but they can be changed to single charging level by the user. A rugged casing for DIN rail mounting, IP20 protection degree. They are extremely compact and cost-effective.

Interconnections: The platform communication for ADELSYSTEM devices allows the connection of all components in a simple but very powerful way. A protocol communication based on Modbus RTU. You can select any of the two buses depending on the application. It allows to communicate with all the accessories provided by ADELSYSTEM and to develop an independent system for electrical continuity. At the same time, it allows monitoring and control all parameters in the system, even from the other side of the world, by means of application tools on the cloud. ADELSYSTEM allows you to implement very simple but sophisticated monitoring and control for your energy system and opens your mind to new ways to approach your applications.

Input Data

Nominal Input Voltage (2 x Vac)	115 – 230 – 277
Input Voltage range (Vac)	90 – 305
Inrush Current ($V_n - I_n$ nom. Load) I^2t	$\leq 16 \text{ A} \leq 5 \text{ msec.}$
Frequency	47 ÷ 63 Hz
Input Current (115 – 230 Vac)	3.3 – 2.2 A
Internal fuse (not replaceable)	6.3 A
External Fuse (recommended) MCB curve B	16 A

General Output Data

Select Output Voltage 12 or 24 Vdc. By:	Jumper Enabling
Turn-On delay after applying mains voltage	1 sec. (max)
Start up with Strong Load (capacitive load)	Yes, Unlimited
Efficiency (at 50% of rated current)	$\geq 91 \%$
Dissipation power load max (W)	28
Continuous current (without battery) $I_{load=I_n}$	I_n
Continuous current (With battery) $I_{load=I_n+I_{batt}}$	2 x I_n
Max. current Output Load (Main) I_{load} (4 sec.)	3 x I_n max.
Max. current Output Load (Back Up) I_{load} (4 sec.)	2 x I_n max.
Push Button or Remote Input Control (RTCONN cable)	Start From Battery Without Main
Time Buffering; min (switch output off without main input)	0.5;2;5;10;15; 20; 30; 45;60;∞
Short-circuit protection	Yes
Over Load protection	Yes
Over Voltage Output protection	Yes (typ. 35 Vdc)
Overheating Thermal protection	Yes

General Data

Insulation voltage (IN/OUT)	3000 Vac
Insulation voltage (input / ground)	1605 Vac
Insulation voltage (Output / ground)	500 Vac
Protection Class (EN/IEC 60529)	IP20
Reliability: MTBF IEC 61709	> 300.000 h

Pollution Degree Environment	2
Connection Terminal Blocks screw Type	2.5mm(24–14AWG)
Connection Terminal	IEC
Protection class (PE Connected)	I, with PE
Dimensions (w-h-d) (Approx.)	100x115x135 mm
Weight (Approx.)	0.85 kg

Load Output 24 Vdc (jumper selection)

Output voltage (at I_n)	20 - 28.8 Vdc
Nominal current $I_n = I_{load}$	10 A $\pm 5\% I_n$
Threshold alarm Battery almost flat	20 – 21 Vdc batt
Protections against total discharge	19 – 20 Vdc batt

Load Output 12 Vdc (jumper selection)

Output voltage (at I_n)	10 - 14.4 Vdc
Nominal current $I_n = I_{load}$	15 A $\pm 5\% I_n$
Threshold alarm Battery almost flat	10 – 11 Vdc batt
Protections against total discharge	9 – 10 Vdc batt

Battery Output

Output Voltage Battery	Follow Out Load
Boost charge (25 °C) (at I_n)	2.4 V/cell.
Max. time Boost Charge	15 h
Min. time Boost Charge	1 min.
Jumper Configuration battery type (V cell)	2.23;2.25;2.27;2.3;
Ni-Cd (optional); when Float Charging mode	NiCd:1.5 (20 cell.)
Charging current max I_{batt}	$I_n \pm 5\%$
Charging current limiting I_{adj}	10 ÷ 100 % / I_{bat}
Reverse battery protection	Yes
Sulfated battery check	Yes (by Jumper)
Detection of element in short circuit	Yes
Quiescent Current on the battery	$\leq 100 \text{ mA}$
Charging Curve automatic: IUoU	4 stages
Remote Input Control (RTCONN cable)	Boost /Float

Signal Output (free switch contacts)

Main or Backup Power	Yes
Low Battery	Yes
Fault Battery	Yes

Type of Signal Output Contact

Max. Current can be switched (EN60947.4.1):	
Max. DC1: 30 Vdc 1 A; AC1: 60 Vac 1A	Resistive load
Min.1mA at 5 Vdc	Min permissible load

Signal Input / Output (RJ45)

Temp. Comp. Battery (with external probe)	Yes (Aux 1)
Modbus RTU	Yes..(Aux 2)
Modbus RTU	Yes (Aux 3)

Climatic Data

Ambient temperature (operation)	-25 ÷ +70°C
De Rating $T^a > 50^\circ\text{C}$	- 2.5%(I_n) / °C
Ambient temperature Storage	-40 ÷ +85°C
Humidity at 25 °C no condensation	95% to 25°C
Cooling	Auto convection

Norms and Certifications

In Conformity to: IEC/EN 60335-2-29 Battery chargers; EN60950 Electrical safety; EN54-4 Fire Detection and fire alarm systems; 89/336/EEC EMC Directive; 2014/35/UE (Low Voltage); DIN41773 (Charging cycle); Emission : IEC 61000-6-3; Immunity: IEC 61000-6-2. CE.