



b.o.b. Sistemi Idraulici S.p.A.

Ampliner
 >>>>

COMPANY
 WITH QUALITY SYSTEM
 CERTIFIED BY DNV
 = ISO 9001/2000 =

BRAS DE LEVAGE « TAL 30 »

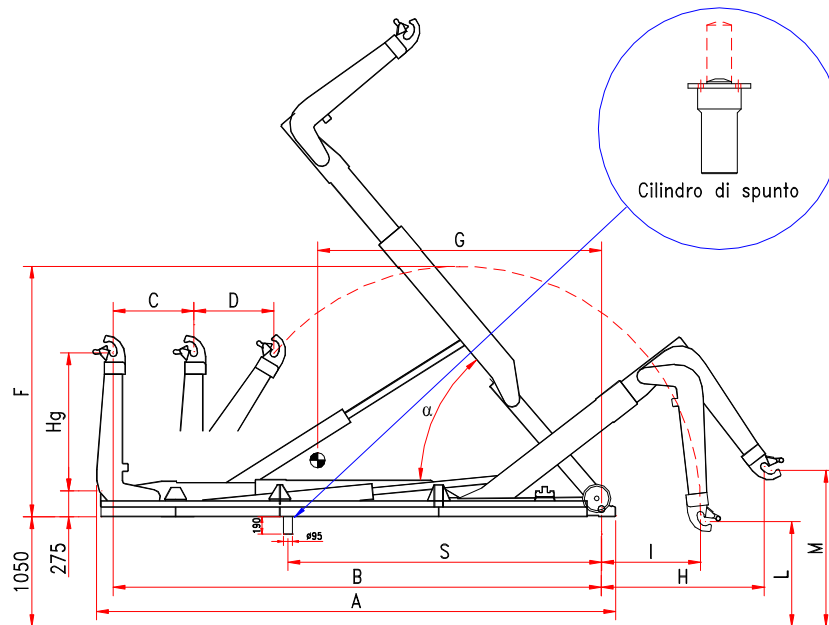

Modèle	Hg	A	B	C	S	F	G	Poids kit	α	Conteneur	min - max
TAL 30 NC	1.425/1.570	6.370	5.960	1.150	3.900	2.785	3.600	3.300 kg	55°		4.400 6.900
TAL 30 N	1.425/1.570	6.570	6.160	1.150	4.100	2.785	3.600	3.350 kg	52°		4.600 7.100
TAL 30 NL	1.425/1.570	6.770	6.360	1.150	4.300	2.785	3.750	3.400 kg	49°		4.800 7.300
TAL 30 L	1.425/1.570	6.960	6.550	1.150	4.500	2.785	3.900	3.450 kg	46°		5.000 7.500

Les données de la présente fiche technique sont indicatives et peuvent être changés par le constructeur sans préavis.

B.O.B. Sistemi Idraulici S.p.A. – Regione Oltre Rea, 61 – 12060 Monchiero (CN) - Italia
 P. I.V.A. 00496180043 - Tel.: +39 (0173) 780002/3 – Fax: +39 (0173) 780004
 Internet: www.bobspa.com - E-mail: info@bobitalev.com