

MÉLANGEUR VILLA M60CM MEAT MIXER VILLA M60CM

Fiche technique / Technical sheet



CARACTÉRISTIQUES

- Entièrement en acier inoxydable
- Cuve motorisée et basculante
- Deux pieds et deux roulettes
- Deux moteurs : Cuve et bras
- Machine totalement sécurisée

OPTIONS

- Bras démontable
- 4 roues pivotantes avec freins et 2 fixes
- Moteur mono

FEATURES

- Full stainless steel
- Motorized and tiltable bowl
- Two feet and two back wheels
- Two motors : bowl and arm
- Machine fully secure

OPTIONS

- Removable arm
- 4 wheels with brakes and 2 fixed wheels
- Single phase motor

MÉLANGEUR VILLA M60CM MEAT MIXER VILLA M60CM

Fiche technique / Technical sheet

Dimensions en mm

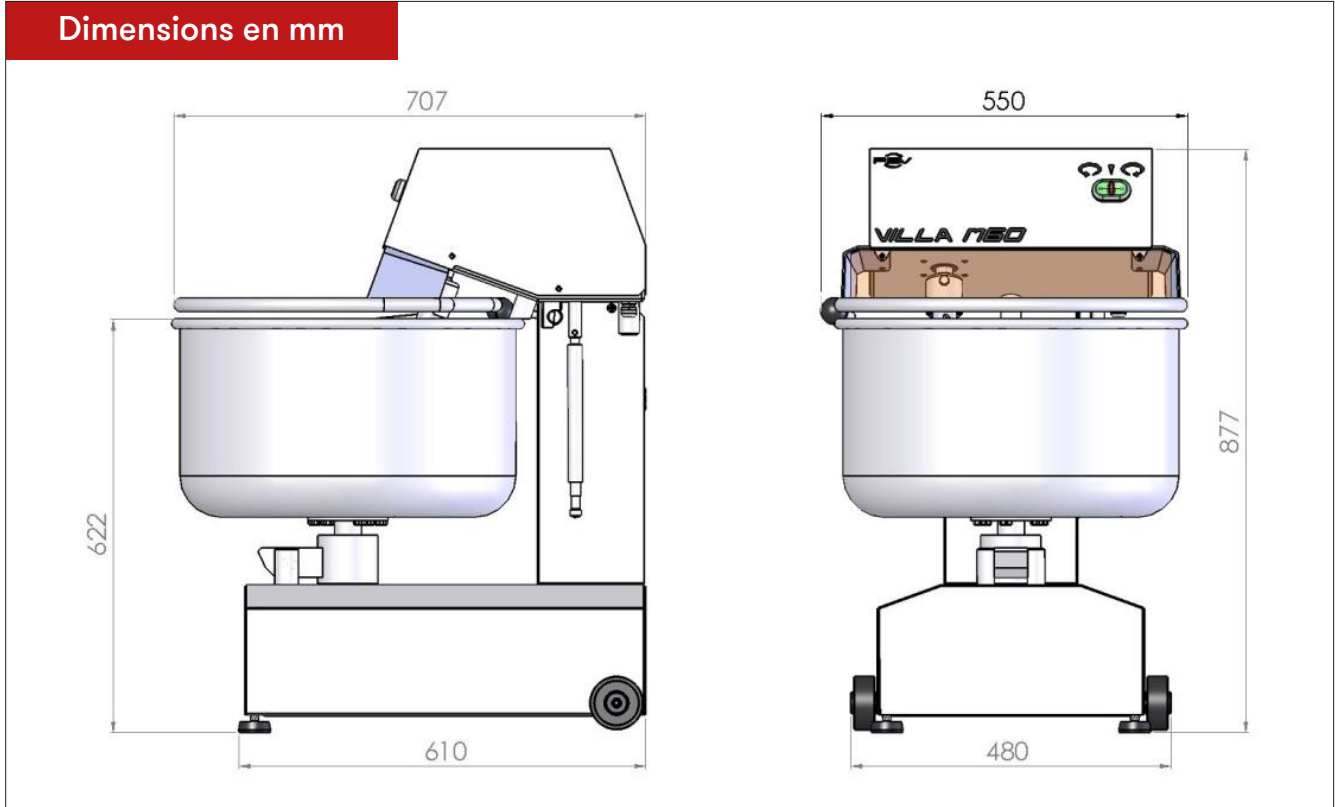

MODÈLE	ENCOMBREMENT (MM)	COLISAGE (MM)	POIDS (KG)	CAPACITÉ (L)	DIMENSIONS DE LA CUVE (MM)	PUISSANCE MOTEUR DE CUVE ET DE BRAS	VITESSE DE ROTATION BRAS ET CUVE (RPM)	TENSION	QUANTITÉ DE MÉLANGE (KG)
MODEL	SIZE (MM)	PACKING DETAILS (MM)	WEIGHT (KG)	CAPACITY (L)	BOWL SIZE (MM)	BOWL MOTOR & KNIVES MOTOR POWER	ROTATION SPEED (RPM)	VOLTAGE	MIX QUANTITY (KG)
M60CM	707 x 550 x 877	900 x 720 x 1250	85	60	500 x 300	Bras/Arm : 0.25kW Cuve/Bowl : 0.12kW	Bras/Arm : 47 Cuve/Bowl : 11	3/380V	Mini : 8 Maxi : 33

