

N 87 SERIES EXPLOSION PROOF PUMPS



N 87 TT.9 E Ex

ADVANTAGES

- High chemical resistance
- Robust design
- Copes well with vapor and condensation
- High level of performance in a compact size
- Excellent price/performance ratio
- Motor approved in accordance with ATEX⁴⁾/IECEx⁵⁾
- High level of gas tightness: 6×10^{-3} mbar x l/s

POSSIBLE AREAS OF USE

- Environmental monitoring – especially in potentially explosive fields
- Process industry
- Chemical industry

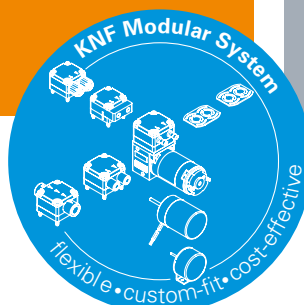

Please visit our website
www.knf.com
to get more information

PERFORMANCE DATA					
Series model	N 87			N 87	
Material design	TT.9 E Ex			TT.9 E 5L Ex	
Pump head	PVDF				
Diaphragm	PTFE-coated				
Valves	FFPM				
Flow rate at atm. pressure (l/min) ¹⁾³⁾	7.5			5.0	
Ultimate vacuum (mbar abs.) ¹⁾	140			170	
Max. operating pressure (bar rel./psig) ¹⁾²⁾	1.5/21.8			1.0	
Permissible ambient temperature (°C) ¹⁾	+5 ... +50			+5 ... +40	
Permissible media temperature (°C) ¹⁾	+5 ... +50			+5 ... +40	
Weight (kg/lbs)	6.7/14.8				
ELECTRICAL DATA					
Voltage (V)	230 ⁴⁾	220 ⁵⁾	115 ⁵⁾	110 ⁵⁾	100 ⁵⁾
Motor	Capacitor motor				
Protection class motor	IP 66				
Protection class pump	IP 55				
Frequency (Hz)	50/60				
Power P ₂ (W)	60	120			
I _N (A)	0.6/0.7	1.09/1.18	2.18/2.12	2.18/2.10	2.28/2.26
Explosion protection pump part	Ex II 2/2G Ex h IIB+H2 T3 Gb			Ex II 2/2G Ex h IIB+H2 T4 Gb	
Explosion protection capacitor motor	Ex II 2G Ex db eb IIC T4 Gb (ATEX) / Ex db eb IIC T4 Gb (IECEx)				

¹⁾expanded performance available upon request | ²⁾bar rel relative to 1013 hPa | ³⁾Flow rate determined at 20 °C, 1000 mbar abs. (Pressure 0 to 1000 mbar abs. in accordance with ISO 21360/ISO 8778) | ⁴⁾ATEX only applies within the EU. | ⁵⁾IECEx only applies outside the EU. Operation of this pump is not permitted in the EU! The pump does not comply with EU directives.

N 87 TT.9 E EX

PERFORMANCE DATA

Series model	Flow rate at atm. pressure (l/min) ³⁾	Max. operating pressure (bar rel./psig) ²⁾	Ultimate vacuum (mbar abs.)
N 87 TT.9 E Ex	7.5	1.5/21.8	140
N 87 TT.9 E 5L Ex	5.0	1.0	170

²⁾bar rel relative to 1013 hPa | ³⁾Flow rate determined at 20 °C, 1000 mbar abs. (Pressure 0 to 1000 mbar abs. in accordance with ISO 21360/ISO 8778)

N 87 TT.9 E EX | TT.9 E 5L EX

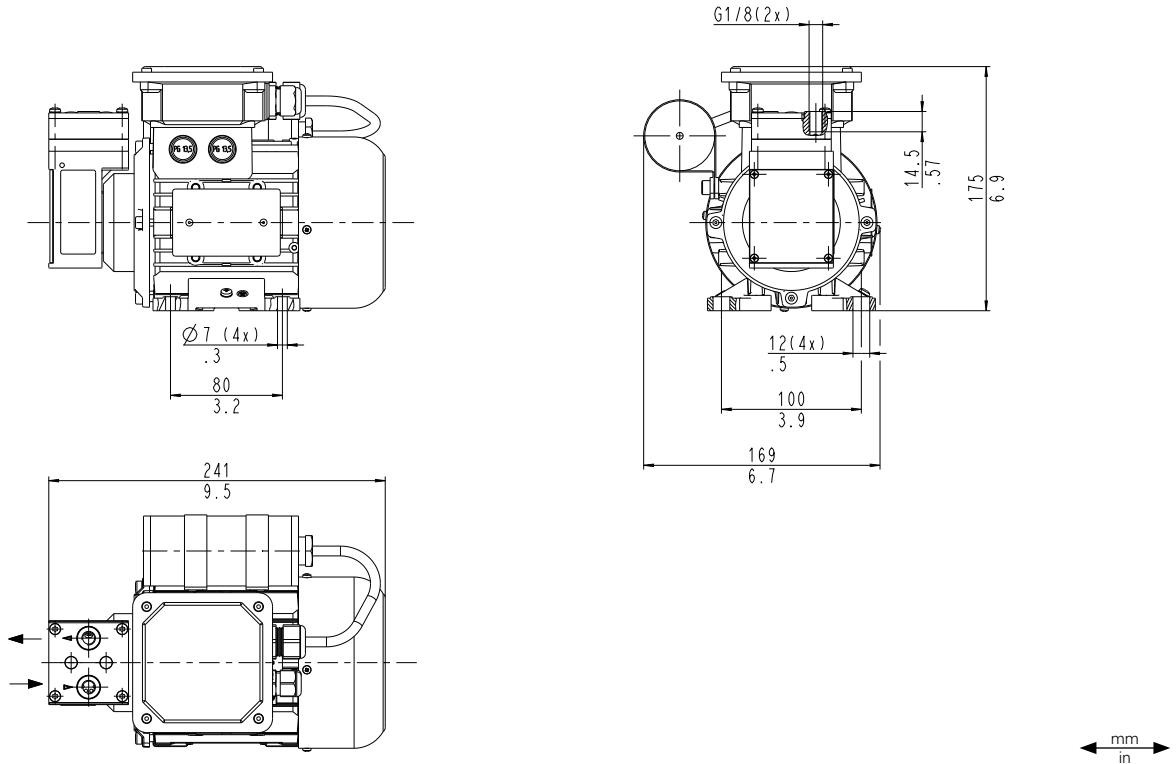

N 87 TT.9 E EX

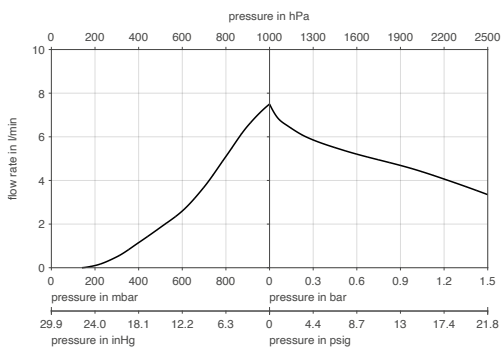

N 87 TT.9 E EX | PUMP DOWN TIME FOR 5 LITER VESSEL

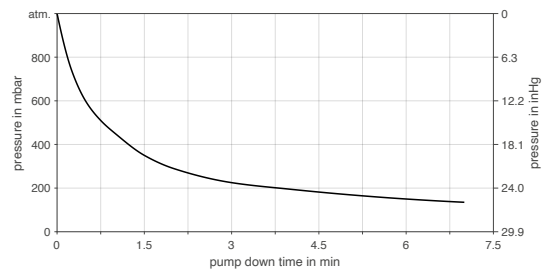



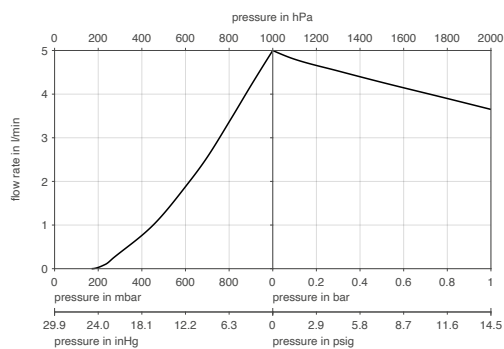

N 87 TT.9 E 5L EX

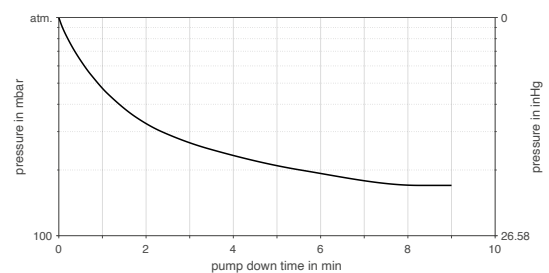

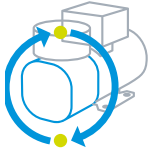
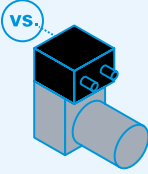

N 87 TT.9 E 5L EX | PUMP DOWN TIME FOR 5 LITER VESSEL

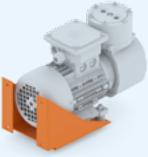

OPTIONS

Description	Illustration	Details
Rotated pump housing		<p>The pump housing may be rotated by 180° at the factory. Any condensate will drain from the pump head, which improves the function of the pump when operating with high condensate concentrations.</p>
Other head materials		<p>The pump head is also available in stainless steel or aluminum for thread fittings or for extreme gas tightness requirements. The gas connections are also available in NPT versions.</p>
Mechanical adjustment of pumping capacity		<p>The pumping capacity can be reduced at the factory to accommodate inlet pressure and for accurate alignment with the customer's system.</p>
Country-specific Ex certificates		<p>Pumps with certificates for KOSHA, PESO, NEPSI, CCC etc. are also available.</p>
Adjustments for higher temperatures		<p>The admissible media and ambient temperature may be increased up to 60 °C by reducing the maximum permitted outlet pressure.</p>
Pump with mounting bracket		<p>The mounting bracket can be mounted at the factory.</p>

ACCESSORIES

Description	Illustration	Part No.	Details
Hose connector for tube ID 6		123363	PVDF, G 1/8
Compression fitting OD 6		014049	PVDF, G 1/8
Set of vibration damping & mounting bracket		313181	

SPARE PARTS:

Description	Illustration	Part No.	Details
Spare parts kit N 87 TT.9 E Ex		322292	Spare parts kit consists of: 1x structured diaphragm, 2x valve plate, 2x cover. This set is required to maintain the pump.

The performance values for the series models shown on this data sheet were determined under test conditions. The actual performance values may differ and depend in particular on the usage conditions and therefore on the specific application, on the parameters of the components involved in the user's system and on any technical modifications carried out which deviate from the standard configuration or the as delivered condition.

If individual designs have been created for specific customers on the basis of series models, other technical performance data may apply. Before operation begins, the relevant operating instructions and/or assembly or installation instructions should be read and the safety information contained in these instructions should be noted. KNF reserves the right to make changes to the product and the associated documentation without prior notice to the customer.



www.knf.com