

N 026.3 SERIES VACUUM PUMPS



N 026.3 ANE with IP 20 motor

ADVANTAGES

- Durable even with difficult operating conditions
- Versatile in vacuum applications

POSSIBLE AREAS OF USE

- Process industry
- Chemical industry

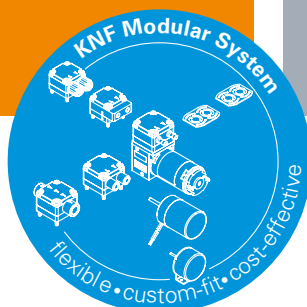

Please visit our website
www.knf.com
to get more information

PERFORMANCE DATA

Series model	N 026.3					
Material design	ANE	AVE	ATE	SNE	SVE	STE
Pump head	Aluminum			Stainless steel		
Diaphragm	CR	FPM	PTFE-coated	CR	FPM	PTFE-coated
Valves	Stainless steel			CR	FPM	PTFE
Flow rate at atm. pressure (l/min)	22.0	19.0	18.0	22.0	19.0	18.0
Ultimate vacuum (mbar abs.)	20	25		20	25	
Permissible ambient temperature (°C)	+5 ... +40					
Permissible media temperature (°C)	+5 ... +40					
Weight (kg/lbs)	5.7/12.6 (IP 20) – 6.6/14.6 (IP 44)			9.0/18.8 (IP 20) – 9.9/21.8 (IP 44)		

ELECTRICAL DATA

Voltage (V)	230					
Motor	Capacitor motor					
Protection class motor	IP 20			IP 44		
Frequency (Hz)	50					
Power P _i (W)	170			180		
I _{max} (A)	0.85			< 1.00		

ACCESSORIES

Description	Part No.	Details
Silencer/Inlet filter	000352	G 1/8
Fine control valve, suction side	011868	with vacuum gauge
Hose connector	000362	G 1/4
Hose connector, stainless steel	020234	G 1/4
Connection box cover	008637	
Wrench for retainer plate	001812	

SPARE PARTS

Description	Part No.	Details
N 026.3 ANE		
Diaphragm	001257	
Countersunk screw	110712	
Reed valve	001288	
Gasket	001273	
N 026.3 ATE		
Diaphragm	001363	
Countersunk screw	110712	
Reed valve	001288	
Gasket	008323	
N 026.3 AVE		
Diaphragm	001391	
Countersunk screw	110712	
Reed valve	001288	
Gasket	008323	
N 026.3 SNE		
Diaphragm	001257	
Countersunk screw	110712	
Reed valve	001272	
N 026.3 STE		
Diaphragm	001363	
Countersunk screw	110712	
Reed valve	001364	
N 026.3 SVE		
Diaphragm	001391	
Countersunk screw	110712	
Reed valve	001392	

The performance values for the series models shown on this data sheet were determined under test conditions. The actual performance values may differ and depend in particular on the usage conditions and therefore on the specific application, on the parameters of the components involved in the user's system and on any technical modifications carried out which deviate from the standard configuration or the as delivered condition.

If individual designs have been created for specific customers on the basis of series models, other technical performance data may apply.

Before operation begins, the relevant operating instructions and/or assembly or installation instructions should be read and the safety information contained in these instructions should be noted.

KNF reserves the right to make changes to the product and the associated documentation without prior notice to the customer.



www.knf.com

N 026.3 ANE | AVE | ATE | SNE | SVE | STE

PERFORMANCE DATA

Series model	Flow rate at atm. pressure (l/min) ¹⁾	Max. operating pressure (bar rel./psig)	Ultimate vacuum (mbar abs.)
N 026.3 ANE	22.0	-	20
N 026.3 AVE	19.0	-	25
N 026.3 ATE	18.0	-	25
N 026.3 SNE	22.0	-	20
N 026.3 SVE	19.0	-	25
N 026.3 STE	18.0	-	25

¹⁾ Liter at STP

N 026.3 A_E (WITH IP 20 MOTOR)

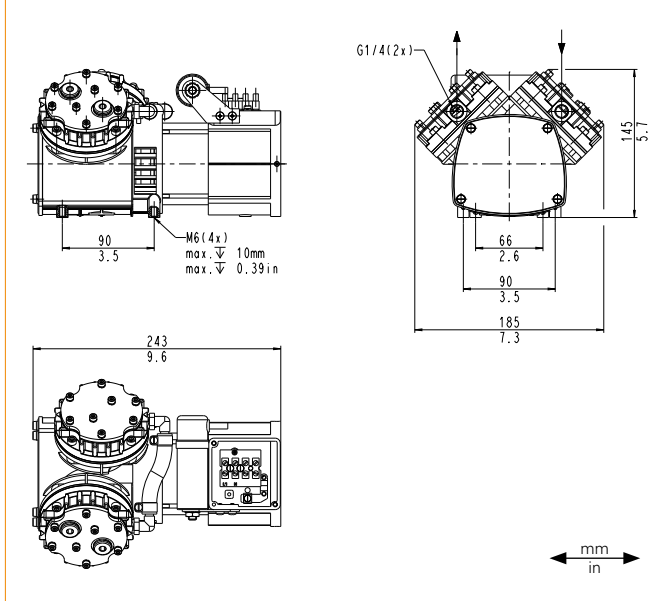

N 026.3 S_E (WITH IP 20 MOTOR)

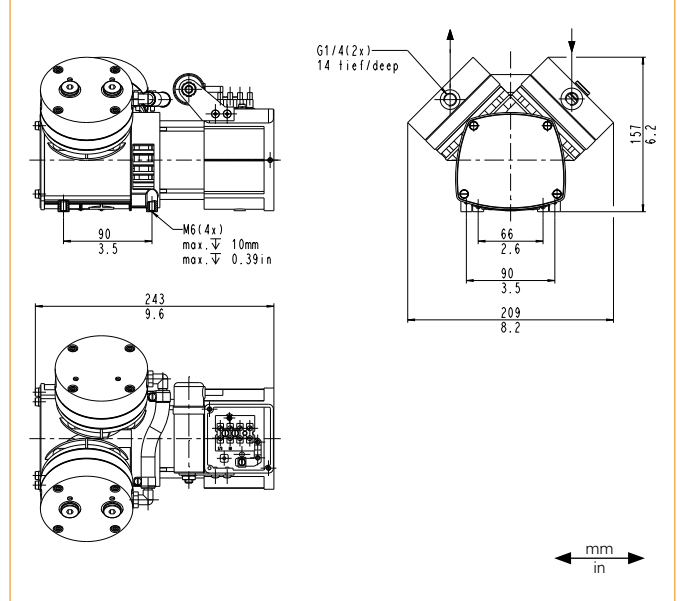

N 026.3 ANE

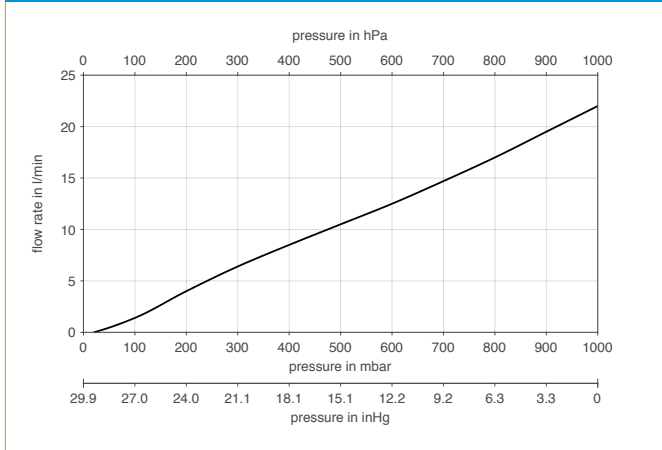

N 026.3 ANE | PUMP DOWN TIME FOR 20 LITER VESSEL

