

MDT 269 J12

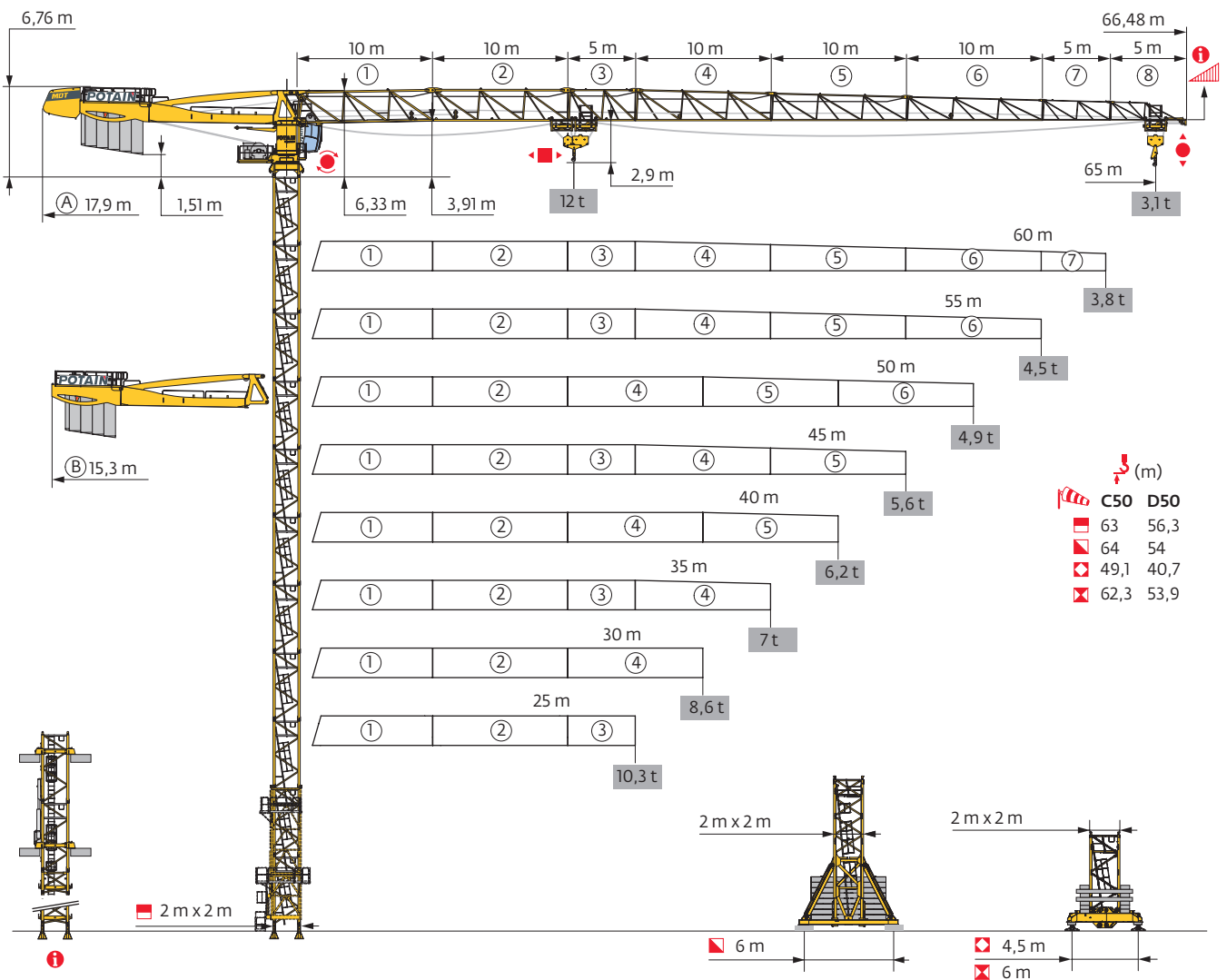

Potain Plus



Power Control

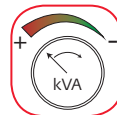

Top Site

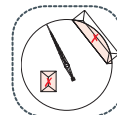

Top Tracing 3

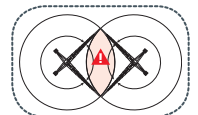

Mât - Réactions / Mast - Reaktionskräfte / Mast - Reactions / Mástil - Reacciones / Torre - Reazioni
 Tramo - Reacções / Реакция опор мачты

| 2 m - P 62B - C50 | | | | | | | | | | |
|-------------------------|--------|------|------|------|------|------|------|------|------|-----|
| AVAIL (m) | 25 | 30 | 35 | 40 | 45 | 50 | 55 | 60 | 65 | |
| (m) | 63 | 63 | 63 | 63 | 63 | 63 | 63 | 63 | 61,3 | |
| /P ₊ (m) | 63 | 63 | 63 | 63 | 63 | 63 | 63 | 63 | 61,3 | |
| | 3,33 m | 2 | 2 | 2 | 2 | 2 | 2 | 2 | 0 | |
| | 5 m | 11 | 11 | 11 | 11 | 11 | 11 | 11 | 12 | |
| F2 (t) | ● | 166 | 164 | 167 | 164 | 165 | 165 | 173 | 174 | 171 |
| | ■ | 305 | 304 | 309 | 306 | 313 | 314 | 313 | 312 | 300 |
| F3 (t) | ● | 116 | 113 | 115 | 112 | 111 | 111 | 117 | 117 | 115 |
| | ■ | 261 | 260 | 263 | 260 | 265 | 266 | 263 | 261 | 250 |
| (m) D50 | 56,3 | 56,3 | 54,6 | 56,3 | 54,6 | 54,6 | 54,6 | 54,6 | 54,6 | |
| /P ₊ (m) D50 | 56,3 | 56,3 | 54,6 | 56,3 | 54,6 | 54,6 | 54,6 | 54,6 | 54,6 | |

| 2 m - V 60A - - C50 | | | | | | | | | |
|-------------------------|--------|------|------|------|------|------|------|------|------|
| AVAIL (m) | 25 | 30 | 35 | 40 | 45 | 50 | 55 | 60 | 65 |
| (m) | 57,3 | 57,3 | 57,3 | 57,3 | 57,3 | 57,3 | 57,3 | 58,9 | 57,3 |
| /P ₊ (m) | 57,3 | 57,3 | 57,3 | 57,3 | 57,3 | 57,3 | 57,3 | 58,9 | 57,3 |
| | 3,33 m | 2 | 2 | 2 | 2 | 2 | 2 | 1 | 2 |
| | 5 m | 9 | 9 | 9 | 9 | 9 | 9 | 10 | 9 |
| F1 (t) | ● | 97 | 96 | 98 | 94 | 98 | 98 | 103 | 99 |
| | ■ | 128 | 127 | 130 | 128 | 132 | 132 | 141 | 133 |
| (m) D50 | 47,3 | 48,9 | 48,9 | 48,9 | 48,9 | 48,9 | 48,9 | 48,9 | 48,9 |
| /P ₊ (m) D50 | 47,3 | 48,9 | 48,9 | 48,9 | 48,9 | 48,9 | 48,9 | 48,9 | 48,9 |

| 2 m - V 63A - - C50 | | | | | | | | | | |
|-------------------------|--------|------|------|-----|------|------|-----|-----|------|-----|
| AVAIL (m) | 25 | 30 | 35 | 40 | 45 | 50 | 55 | 60 | 65 | |
| (m) | 62,3 | 62,3 | 62,3 | 64 | 62,3 | 62,3 | 64 | 64 | 62,3 | |
| /P ₊ (m) | 62,3 | 62,3 | 62,3 | 64 | 62,3 | 62,3 | 64 | 64 | 62,3 | |
| | 3,33 m | 2 | 2 | 2 | 1 | 2 | 2 | 1 | 2 | |
| | 5 m | 9 | 9 | 9 | 10 | 9 | 9 | 10 | 9 | |
| F1 (t) | ● | 113 | 113 | 114 | 115 | 114 | 115 | 119 | 120 | 116 |
| | ■ | 161 | 160 | 163 | 169 | 165 | 165 | 172 | 171 | 166 |
| (m) D50 | 52,3 | 54 | 54 | 54 | 54 | 54 | 54 | 54 | 54 | |
| /P ₊ (m) D50 | 52,3 | 54 | 54 | 54 | 54 | 54 | 54 | 54 | 54 | |

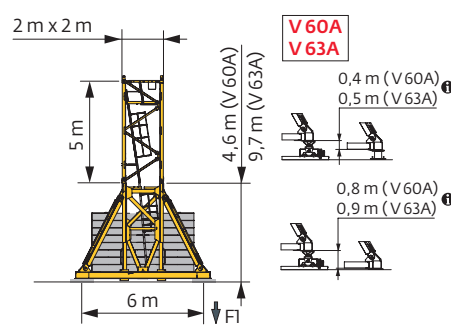
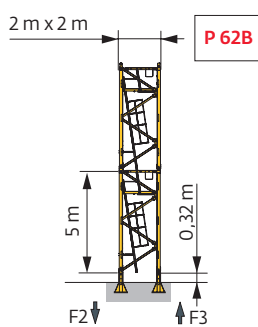

i Accès motorisés types Cab-IN et TCL : compositions de mât, de lest de base et réactions adaptées. / Motorisierter Zugang vom Typ Cab-IN und TCL : Mastzusammensetzung, Grundballast und Reaktionskräfte sind angepasst. / Motorized accesses of Cab-IN and TCL types: Adapted mast composition, base ballast and reactions. / Acceso a cabina con elevador tipo Cab-IN (interno) y tipo TCL (externo): Adaptación de composición de mástil, lastre de base y reacciones. / Accessi motorizzati di tipo Cab-IN e TCL: composizioni elementi torre, zavorre di base e reazioni aggiornate. / Acessos motorizados tipo Cab-IN e TCL: composições de coluna, lastro da base e reacções adaptadas. / Лифты Cab-IN и TCL для подъема крановщиков: адаптированная композиция мачты, базовый балласт и нагрузки.

2 m - ZD 463 - C50

| ΔΔΔ (m) | 25 | 30 | 35 | 40 | 45 | 50 | 55 | 60 | 65 | |
|-------------|--------|------|------|------|------|------|------|------|------|---|
| Δ (m) | 47,4 | 49,1 | 47,4 | 49,1 | 47,4 | 47,4 | 47,4 | 45,7 | 45,7 | |
| Δ/P (m) | 47,4 | 49,1 | 47,4 | 49,1 | 47,4 | 47,4 | 47,4 | 45,7 | 45,7 | |
| Δ | 3,33 m | 0 | 2 | 0 | 2 | 0 | 0 | 0 | 1 | 1 |
| | 5 m | 9 | 8 | 9 | 8 | 9 | 9 | 8 | 8 | |
| Fl (t) | ● 98 | 101 | 99 | 101 | 98 | 98 | 103 | 101 | 102 | |
| | ■ 115 | 124 | 117 | 125 | 119 | 119 | 118 | 108 | 113 | |
| Δ (m) D50 | 40,7 | 40,7 | 40,7 | 40,7 | 40,7 | 40,7 | 40,7 | 40,7 | 40,7 | |
| Δ/P (m) D50 | 40,7 | 40,7 | 40,7 | 40,7 | 40,7 | 40,7 | 40,7 | 40,7 | 40,7 | |

2 m - ZX 6830 - C50

| ΔΔΔ (m) | 25 | 30 | 35 | 40 | 45 | 50 | 55 | 60 | 65 |
|-------------|--------|------|------|------|------|------|------|------|------|
| Δ (m) | 62,3 | 62,3 | 62,3 | 62,3 | 62,3 | 60,6 | 62,3 | 62,3 | 60,6 |
| Δ/P (m) | 62,3 | 62,3 | 62,3 | 62,3 | 62,3 | 60,6 | 62,3 | 62,3 | 60,6 |
| Δ | 3,33 m | 0 | 0 | 0 | 0 | 1 | 0 | 0 | 1 |
| | 5 m | 12 | 12 | 12 | 12 | 11 | 12 | 12 | 11 |
| Fl (t) | ● 111 | 108 | 112 | 109 | 110 | 106 | 113 | 114 | 110 |
| | ■ 156 | 154 | 157 | 155 | 159 | 151 | 158 | 157 | 153 |
| Δ (m) D50 | 53,9 | 53,9 | 53,9 | 53,9 | 53,9 | 53,9 | 53,9 | 53,9 | 53,9 |
| Δ/P (m) D50 | 53,9 | 53,9 | 53,9 | 53,9 | 53,9 | 53,9 | 53,9 | 53,9 | 53,9 |

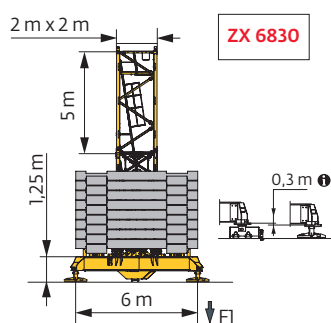
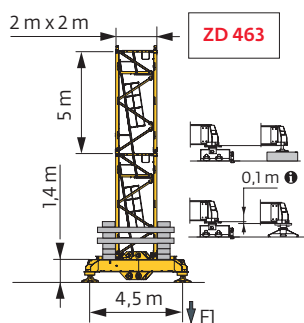

Ancrages / Verankerungen / Anchorages / Anclajes / Ancoraggi
 Ancoragem / нкєра



Lest de base / Grundballast / Base ballast / Lastre de base / Zavorra di base
 Lastro da base / Базовый Балласт

⚖️(t) / 📏2 m - V 60A - 🚛 - C50

| ΔVΔL (m) | 25 | 30 | 35 | 40 | 45 | 50 | 55 | 60 | 65 |
|----------|------|-----|-----|-----|-----|-----|-----|-----|-----|
| 58,9 | 132 | | | | | | | | |
| 57,3 | 132 | 132 | 132 | 120 | 132 | 132 | 120 | 120 | 120 |
| 52,3 | 96 | 96 | 96 | 96 | 96 | 96 | 96 | 96 | 96 |
| 47,3 | 72 | 72 | 72 | 72 | 60 | 72 | 72 | 72 | 72 |
| ↓ (m) | 42,3 | 60 | 60 | 60 | 60 | 48 | 48 | 60 | 60 |
| | 37,3 | 48 | 48 | 48 | 48 | 36 | 36 | 48 | 48 |
| | 32,3 | 48 | 48 | 48 | 48 | 36 | 36 | 36 | 36 |
| | 27,3 | 48 | 48 | 48 | 48 | 36 | 36 | 36 | 24 |
| | 22,3 | 48 | 48 | 48 | 48 | 36 | 36 | 36 | 24 |
| | 17,3 | 48 | 48 | 48 | 48 | 36 | 36 | 36 | 24 |

⚖️(t) / 📏2 m - V 63A - 🚛 - C50

| ΔVΔL (m) | 25 | 30 | 35 | 40 | 45 | 50 | 55 | 60 | 65 |
|----------|------|-----|-----|-----|-----|-----|-----|-----|-----|
| 64 | 180 | | | 180 | | | 180 | | |
| 62,3 | 180 | 180 | 180 | 168 | 180 | 180 | 168 | 168 | 168 |
| 57,3 | 132 | 132 | 132 | 132 | 132 | 132 | 132 | 120 | 132 |
| 52,3 | 108 | 96 | 108 | 96 | 96 | 108 | 96 | 96 | 96 |
| ↓ (m) | 47,3 | 72 | 72 | 72 | 72 | 72 | 72 | 72 | 72 |
| | 42,3 | 60 | 60 | 60 | 60 | 48 | 48 | 60 | 60 |
| | 37,3 | 48 | 48 | 48 | 48 | 36 | 36 | 48 | 48 |
| | 32,3 | 36 | 36 | 36 | 36 | 36 | 36 | 36 | 36 |
| | 27,3 | 36 | 36 | 36 | 36 | 36 | 36 | 36 | 24 |
| | 22,3 | 36 | 36 | 36 | 36 | 36 | 36 | 36 | 24 |

⚖️(t) / 📏2 m - ZD 463 - 🚛 - C50

| ΔVΔL (m) | 25 | 30 | 35 | 40 | 45 | 50 | 55 | 60 | 65 |
|----------|------|-----|-----|-----|-----|-----|-----|-----|-----|
| 49,1 | 125 | | 125 | | | | | | |
| 47,4 | 120 | 120 | 120 | 115 | 115 | 115 | 125 | | |
| 45,7 | 115 | 110 | 115 | 110 | 105 | 105 | 120 | 120 | 120 |
| ↓ (m) | 40,7 | 95 | 95 | 95 | 90 | 85 | 85 | 100 | 100 |
| | 35,7 | 80 | 80 | 75 | 75 | 75 | 75 | 80 | 80 |
| | 30,7 | 80 | 80 | 75 | 75 | 75 | 75 | 70 | 60 |
| | 25,7 | 80 | 80 | 75 | 75 | 75 | 75 | 70 | 60 |
| | 20,7 | 80 | 80 | 75 | 75 | 75 | 75 | 70 | 60 |

⚖️(t) / 📏2 m - ZX 6830 - 🚛 - C50

| ΔVΔL (m) | 25 | 30 | 35 | 40 | 45 | 50 | 55 | 60 | 65 |
|----------|------|-----|-----|-----|-----|-----|-----|-----|-----|
| 62,3 | 171 | 161 | 171 | 161 | 161 | 161 | | 161 | |
| 60,6 | 161 | 151 | 151 | 151 | 151 | 151 | 151 | 141 | 151 |
| 55,6 | 111 | 111 | 111 | 111 | 111 | 111 | 101 | 101 | 111 |
| ↓ (m) | 50,6 | 81 | 81 | 81 | 81 | 81 | 81 | 81 | 81 |
| | 45,6 | 61 | 61 | 61 | 61 | 51 | 51 | 61 | 71 |
| | 40,6 | 51 | 51 | 51 | 51 | 41 | 41 | 51 | 51 |
| | 35,6 | 41 | 41 | 41 | 41 | 41 | 41 | 41 | 41 |
| | 30,6 | 41 | 41 | 41 | 41 | 41 | 41 | 31 | 21 |
| | 25,6 | 41 | 41 | 41 | 41 | 41 | 41 | 31 | 21 |
| | 20,6 | 41 | 41 | 41 | 41 | 41 | 41 | 31 | 21 |

Courbes de charges / Lastkurven / Load curves / Curvas de cargas / Curve di carico / Curvas de carga / Кривые нагрузок



| ↕ (m) | | 17 | 20 | 22 | 25 | 27 | 30 | 32 | 35 | 37 | 40 | 42 | 45 | 47 | 50 | 52 | 55 | 57 | 60 | 62 | 65 | m | |
|-------|------------|-------------|----|------|------|------|-----|-----|-----|-----|-----|-----|-----|-----|-----|-----|-----|-----|-----|-----|-----|------|------|
| ↕ | ↕ 12 t | ↕ | | | | | | | | | | ↕ | | | | | | | | | | | |
| ↕ | ↕ 6 t | ↕ | | | | | | | | | | ↕ | | | | | | | | | | | |
| 65 | 3,1 → 18,9 | 34,8 - 37,1 | 12 | 11,3 | 10,2 | 8,8 | 8,1 | 7,2 | 6,6 | 6 | 6 | 5,5 | 5,2 | 4,8 | 4,5 | 4,1 | 3,9 | 3,6 | 3,5 | 3,3 | 3,1 | 2,95 | t |
| | 3,1 → 20,1 | 36,1 - 38,3 | 12 | 12 | 10,9 | 9,4 | 8,6 | 7,6 | 7 | 6,2 | 6 | 5,8 | 5,4 | 5 | 4,7 | 4,4 | 4,2 | 3,9 | 3,7 | 3,5 | 3,3 | 3,1 | t P+ |
| 60 | 3,1 → 20,2 | 37,2 - 39,2 | 12 | 12 | 10,9 | 9,5 | 8,7 | 7,7 | 7,2 | 6,5 | 6 | 5,9 | 5,5 | 5,1 | 4,8 | 4,4 | 4,2 | 3,9 | 3,7 | 3,5 | | | t |
| | 3,1 → 21,2 | 38,3 - 41 | 12 | 12 | 11,5 | 10 | 9,2 | 8,1 | 7,5 | 6,7 | 6,3 | 6 | 5,8 | 5,3 | 5,1 | 4,7 | 4,5 | 4,2 | 4 | 3,8 | | | t P+ |
| 55 | 3,1 → 20,1 | 36,9 - 40 | 12 | 12 | 10,8 | 9,4 | 8,6 | 7,6 | 7,1 | 6,4 | 6 | 6 | 5,6 | 5,2 | 5 | 4,6 | 4,4 | 4,2 | | | | | t |
| | 3,1 → 21,1 | 39,7 - 43 | 12 | 12 | 11,5 | 10 | 9,2 | 8,2 | 7,7 | 6,9 | 6,5 | 6 | 6 | 5,7 | 5,4 | 5 | 4,8 | 4,5 | | | | | t P+ |
| 50 | 3,1 → 20 | 35,9 - 38,6 | 12 | 11,9 | 10,7 | 9,3 | 8,5 | 7,5 | 6,9 | 6,2 | 6 | 5,8 | 5,5 | 5,1 | 4,8 | 4,5 | | | | | | | t |
| | 3,1 → 20,7 | 38,7 - 42 | 12 | 12 | 11,3 | 9,8 | 9 | 8 | 7,5 | 6,7 | 6,3 | 6 | 6 | 5,5 | 5,3 | 4,9 | | | | | | | t P+ |
| 45 | 3,1 → 20 | 36,2 - 39 | 12 | 12 | 10,8 | 9,3 | 8,5 | 7,5 | 6,9 | 6,2 | 6 | 5,8 | 5,5 | 5,1 | | | | | | | | | t |
| | 3,1 → 20,9 | 39,1 - 42 | 12 | 12 | 11,4 | 9,9 | 9,1 | 8,1 | 7,5 | 6,8 | 6,4 | 6 | 6 | 5,6 | | | | | | | | | t P+ |
| 40 | 3,1 → 20,6 | 38,2 - 40 | 12 | 12 | 11,2 | 9,7 | 8,9 | 7,9 | 7,4 | 6,6 | 6,2 | 6 | | | | | | | | | | | t |
| | 3,1 → 21,8 | | 12 | 12 | 11,9 | 10,3 | 9,5 | 8,5 | 7,9 | 7,1 | 6,7 | 6,1 | | | | | | | | | | | t P+ |
| 35 | 3,1 → 20,1 | | 12 | 12 | 10,9 | 9,4 | 8,7 | 7,7 | 7,1 | 6,4 | | | | | | | | | | | | | t |
| | 3,1 → 21,2 | | 12 | 12 | 11,5 | 10,1 | 9,3 | 8,3 | 7,7 | 6,9 | | | | | | | | | | | | | t P+ |
| 30 | 3,1 → 20,8 | | 12 | 12 | 11,3 | 9,8 | 9 | 8 | | | | | | | | | | | | | | | t |
| | 3,1 → 21,9 | | 12 | 12 | 11,9 | 10,4 | 9,6 | 8,5 | | | | | | | | | | | | | | | t P+ |
| 25 | 3,1 → 20,5 | | 12 | 12 | 11,1 | 9,7 | | | | | | | | | | | | | | | | | t |
| | 3,1 → 21,6 | | 12 | 12 | 11,8 | 10,3 | | | | | | | | | | | | | | | | | t P+ |

$↕ = ↕ - 0,53 \text{ t max.}$



| ↕ (m) | | 17 | 20 | 22 | 25 | 27 | 30 | 32 | 35 | 37 | 40 | 42 | 45 | 47 | 50 | 52 | 55 | 57 | 60 | 62 | 65 | m | |
|-------|------------|-------------|----|------|------|------|-----|-----|-----|-----|-----|-----|-----|-----|-----|-----|-----|-----|-----|------|-----|-----|------|
| ↕ | ↕ 12 t | ↕ | | | | | | | | | | ↕ | | | | | | | | | | | |
| ↕ | ↕ 6 t | ↕ | | | | | | | | | | ↕ | | | | | | | | | | | |
| 65 | 2,4 → 19 | 35,1 - 35,4 | 12 | 11,4 | 10,3 | 8,9 | 8,2 | 7,2 | 6,7 | 6 | 5,7 | 5,2 | 4,8 | 4,4 | 4,1 | 3,8 | 3,6 | 3,3 | 3,1 | 2,95 | 2,8 | 2,6 | t |
| | 2,4 → 20,2 | 36,4 - 36,5 | 12 | 12 | 11 | 9,5 | 8,6 | 7,6 | 7 | 6,3 | 5,9 | 5,4 | 5,1 | 4,7 | 4,4 | 4 | 3,8 | 3,6 | 3,4 | 3,2 | 3 | 2,8 | t P+ |
| 60 | 2,4 → 20,3 | 37,6 - 37,5 | 12 | 12 | 11 | 9,6 | 8,8 | 7,8 | 7,2 | 6,5 | 6,1 | 5,6 | 5,2 | 4,8 | 4,5 | 4,1 | 3,9 | 3,6 | 3,4 | 3,2 | | | t |
| | 2,4 → 21,3 | 38,6 - 39,1 | 12 | 12 | 11,6 | 10,1 | 9,2 | 8,2 | 7,5 | 6,8 | 6,3 | 5,8 | 5,5 | 5 | 4,8 | 4,4 | 4,2 | 3,9 | 3,7 | 3,5 | | | t P+ |
| 55 | 2,4 → 20,2 | 37,2 - 38 | 12 | 12 | 10,9 | 9,4 | 8,7 | 7,7 | 7,1 | 6,4 | 6 | 5,7 | 5,3 | 4,9 | 4,7 | 4,3 | 4,1 | 3,9 | | | | | t |
| | 2,4 → 21,2 | 40 - 40,5 | 12 | 12 | 11,5 | 10,1 | 9,3 | 8,3 | 7,7 | 7 | 6,6 | 6 | 5,8 | 5,4 | 5,1 | 4,7 | 4,5 | 4,2 | | | | | t P+ |
| 50 | 2,4 → 20,1 | 36,2 - 37 | 12 | 12 | 10,8 | 9,3 | 8,5 | 7,5 | 7 | 6,3 | 6 | 5,5 | 5,2 | 4,8 | 4,5 | 4,2 | | | | | | | t |
| | 2,4 → 20,8 | 39 - 39,7 | 12 | 12 | 11,3 | 9,9 | 9,1 | 8,1 | 7,5 | 6,8 | 6,4 | 5,9 | 5,7 | 5,2 | 5 | 4,6 | | | | | | | t P+ |
| 45 | 2,4 → 20,1 | 36,5 - 37,3 | 12 | 12 | 10,8 | 9,4 | 8,6 | 7,6 | 7 | 6,3 | 6 | 5,5 | 5,2 | 4,8 | | | | | | | | | t |
| | 2,4 → 21 | 39,4 - 40,2 | 12 | 12 | 11,4 | 10 | 9,2 | 8,2 | 7,6 | 6,9 | 6,5 | 6 | 5,7 | 5,3 | | | | | | | | | t P+ |
| 40 | 2,4 → 20,7 | 38,5 - 39,3 | 12 | 12 | 11,3 | 9,8 | 9 | 8 | 7,4 | 6,7 | 6,3 | 5,9 | | | | | | | | | | | t |
| | 2,4 → 21,8 | | 12 | 12 | 11,9 | 10,4 | 9,6 | 8,5 | 8 | 7,2 | 6,8 | 6,2 | | | | | | | | | | | t P+ |
| 35 | 2,4 → 20,2 | | 12 | 12 | 10,9 | 9,5 | 8,7 | 7,7 | 7,2 | 6,5 | | | | | | | | | | | | | t |
| | 2,4 → 21,3 | | 12 | 12 | 11,6 | 10,2 | 9,3 | 8,3 | 7,8 | 7 | | | | | | | | | | | | | t P+ |
| 30 | 2,4 → 20,9 | | 12 | 12 | 11,3 | 9,9 | 9,1 | 8,1 | | | | | | | | | | | | | | | t |
| | 2,4 → 22 | | 12 | 12 | 12 | 10,5 | 9,6 | 8,6 | | | | | | | | | | | | | | | t P+ |
| 25 | 2,4 → 20,6 | | 12 | 12 | 11,2 | 9,7 | | | | | | | | | | | | | | | | | t |
| | 2,4 → 21,7 | | 12 | 12 | 11,8 | 10,3 | | | | | | | | | | | | | | | | | t P+ |



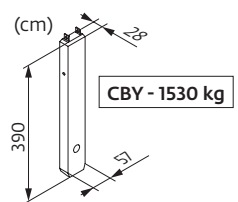
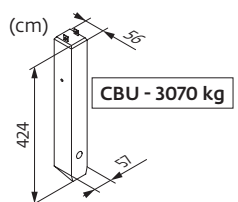
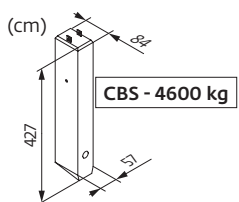

$↕ = ↕ - 0,17 \text{ t max.}$

Poids de flèche & lest de contre-flèche / Auslegergewicht & Gegenauslegerballast / Jib weight & counter-jib ballast / Peso de flecha y lastre de contra-flecha/Peso del braccio & zavorra di contro-braccio/Peso da lança & lastro da contra lança/Вес стрелы и балласт контр-стрелы



| ↕ | ↕ (kg) (+/- 5%) | | | ↕ | | ↕ | | | |
|------|-----------------|-------|-------|---------|---------|--------|---------|---------|--------|
| | ↕ | ↕ | ↕↔↕ | 4600 kg | 1530 kg | ↕ (kg) | 3070 kg | 1530 kg | ↕ (kg) |
| 65 m | 12450 | 12140 | 12525 | 5 | 1 | 24530 | 7 | 2 | 24550 |
| 60 m | 12170 | 11870 | 12230 | 5 | 1 | 24530 | 7 | 2 | 24550 |
| 55 m | 11860 | 11560 | 11920 | 5 | 0 | 23000 | 7 | 1 | 23020 |
| 50 m | 10910 | 10610 | 10970 | 4 | 1 | 19930 | 6 | 1 | 19950 |
| 45 m | 11040 | 10740 | 11100 | 4 | 1 | 19930 | 6 | 1 | 19950 |
| 40 m | 10090 | 9790 | 10150 | 4 | 0 | 18400 | 6 | 0 | 18420 |
| 35 m | 9940 | 9640 | 10000 | 3 | 2 | 16860 | 5 | 1 | 16880 |
| 30 m | 9110 | 8810 | 9170 | 3 | 1 | 15330 | 5 | 0 | 15350 |
| 25 m | 8620 | 8320 | 8680 | 3 | 0 | 13800 | 4 | 1 | 13810 |



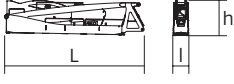

Encombrenment et poids / Abmessungen und Gewicht / Dimensions and weight / Dimensiones y peso / Ingombro e peso
 dimensões e pesos / габаритные размеры и вес

Partie tournante / Drehender Kranteil / Slewing crane part / Parte giratoria
 Parte rotante / Parte rotativa / Поворотная часть :  65 m -  -  -  50 LVF

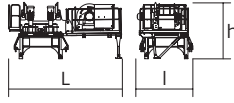
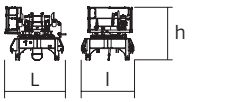
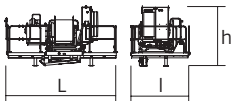
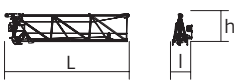
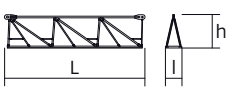
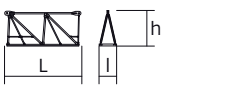
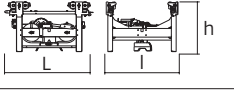
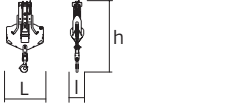
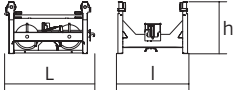
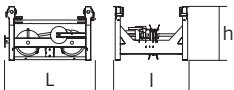
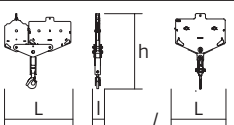

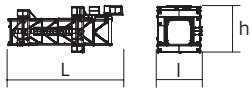
| Partie tournante / Drehender Kranteil / Slewing crane part Parte giratoria / Parte rotante / Parte rotativa Поворотная часть | | L (m) | I (m) | h (m) | kg (+/- 5%) |
|--|---|------------------|--------------------------|-----------------------------|-----------------------------|
| Contre-flèche / Gegenausleger Counter-jib / Contra-flecha Controbraccio / Contra-lança Контр-стрела |  | 11 11 | 1,17 1,17 | 2,47 2,47 | 8715 8450 |
| Mât-cabine + cabine / Kabinenmast + Kabine Cab mast + cab / Mástil-cabina + cabina Portaralla superiore + cabina / Tramo-cabina + cabina Секция мачты кабины + кабина |  | 4,9 | 2,22 | 2,49 | 5300 |
| Pivot + treuil de levage (+ câble) / Krankopf + Hubwerk (+ Seil) Towerhead + Hoisting winch (+ rope) Pivote + Mecanismo de elevación (+ cabo) Portaralla + Argano di sollevamento (+ fune) Pivot + Guincho de elevação (+ cabo) Секция поворотной части + Подъемная лебёдка (+ канатом) |  | 5,14 | 2,51 | 2,76 | 8475 |
| Pivot / Krankopf Towerhead / Pivote Portaralla / Pivot Секция поворотной части |  | 2,83 | 2,46 | 2,47 | 5300 |
| Treuil de levage (+ câble) / Hubwerk (+ Seil) Hoisting winch (+ rope) / Mecanismo de elevación (+ cabo) Argano di sollevamento (+ fune) Guincho de elevação (+ cabo) Подъемная лебёдка (+ канатом) |  | 4,27 | 2,3 | 2,32 | 4500 |
| Elément de flèche / Auslegerement Jib section / Elemento de flecha Elemento di braccio / Elemento de lança Секция стрелы |  | 10,82 | 1,72 | 2,7 | 3520 |
| Elément de flèche / Auslegerement Jib section / Elemento de flecha Elemento di braccio / Elemento de lança Секция стрелы |  | ② ④ ⑤ ⑥ | 1,2 1,2 1,2 1,2 | 2,42 2,39 2,1 1,83 | 2420 1560 1235 795 |
| Elément de flèche / Auslegerement jib section / Elemento de flecha Elemento di braccio / Elemento de lança Секция стрелы |  | ③ ⑦ ⑧ | 1,2 1,2 1,2 | 2,39 1,53 1,39 | 960 310 220 |
| Chariot / Laufkatze Trolley / Carrello Carro / Carro-distribuidor Тележка |  | 1,87 | 1,51 | 1,05 | 400 |
| Moufle / Hubflasche Pulley block / Aparejo Bozzello / Cadernal Полиспаст |  | 1,19 | 0,43 | 2,31 | 455 |
| Chariot / Laufkatze Trolley / Carrello Carro / Carro-distribuidor Тележка |  | 1,57 | 1,51 | 0,98 | 210 |
| Chariot / Laufkatze Trolley / Carrello Carro / Carro-distribuidor Тележка |  | 1,7 1,86 | 1,51 1,51 | 1,03 0,98 | 245 236 |
| Moufle / Hubflasche Pulley block / Aparejo Bozzello / Cadernal Полиспаст |  | 1,65 1,09 | 0,22 0,27 | 1,78 1,62 | 450 265 |

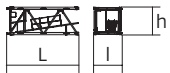
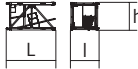
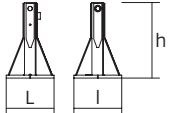
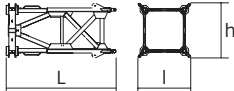
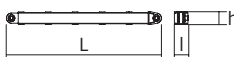
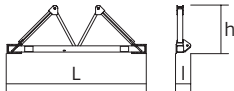
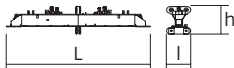
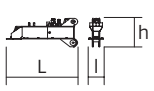
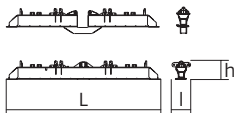
| Pyłone / Kranturm / Crane tower Mástil / Torre / Torre Башня крана | | L (m) | I (m) | h (m) | kg (+/- 5%) | |
|---|---|------------------------------|----------------------------|------------------------------|------------------------------|--------------|
| T 61 |  | 10,83 | 4,14 | 4,47 | 9700 | |
| K 649B KM 649E |  | 10,23 10,29 | 2,07 2,03 | 2,03 2,03 | 5290 4850 | |
| KR 649A KRMT 649A K 649A KMT 649A |  | 5,23 5,23 5,23 5,23 | 2,1 2,1 2,07 2,07 | 2,08 2,08 2,03 2,03 | 3250 3050 2805 2570 | |
| K 649C KRMT 649C |  | 3,57 3,57 | 2,07 2,1 | 2,03 2,08 | 1985 2450 | |
| Pieds de scellement / Verankerungsfüße Fixing angles / Pie de empotramiento Montante da annegare / Angulos fixadores анкера |  | P 62B | 0,65 | 0,65 | 1,27 | 295 |
| Mât-châssis / Grundmasteinheit Basic mast unit / Tramo-chassis Elemento base / Tramo-chassis Мачта для крепления к шасси |  | V 60A V 63A | 5,01 10,02 | 2,41 2,41 | 2,41 2,41 | 4390 7485 |
| Haubans / Mastabstützungen Struts / Tornapuntas Puntoni / Escoras Растяжка |  | V 60A V 63A | 4,51 4,51 | 0,29 0,33 | 0,29 0,33 | 420 515 |
| Sommier / Unterwagenhälfte Half-bearer / Testero Testata / Estrutura base Траверса |  | V 60A V 63A | 6,7 6,7 | 0,7 0,7 | 2,31 2,31 | 1600 1850 |
| Bras de croix / Fundamentkreuzträger Cross girder / Braço en cruz Braccio croce / Braço da cruz Поперечная балка |  | ZD 463 | 7,65 | 1,17 | 1,36 | 3585 |
| 1/2 Bras de croix / 1/2 Fundamentkreuzträger 1/2 Cross girder / 1/2 Braço en cruz 1/2 Braccio croce / 1/2 Braço da cruz 1/2 Поперечная балка |  | ZD 463 | 3,41 | 0,7 | 1,35 | 1655 |
| Bras de croix / Fundamentkreuzträger Cross girder / Braço en cruz Braccio croce / Braço da cruz Поперечная балка |  | ZX 6830 | 9,1 9,1 | 0,76 1,12 | 1,48 1,1 | 5445 5265 |

Mécanismes / Triebwerke / Mechanisms / Mecanismos / Meccanismi
 Механизмы / Механизмы

| 400 V - 50 Hz | | | | | | | | | | | | ch - PS hp | kW | |
|---------------|-------------------------|------------------------|---|-----|------|------|------|---------|---------|-----|----|---------------|-------|--|
| | 50 LVF 30 Optima | m/min | 32 | 41 | 56,5 | 81,5 | 16,5 | 21,5 | 29,5 | 41 | 50 | 37 | 337 m | |
| | | t | 6 | 4,5 | 3 | 1 | 12 | 9 | 6 | 2,3 | | | | |
| | 75 HPL™ 30 | m/min | 44 | 57 | 81 | 137 | 220 | 23 | 30 | 43 | 77 | 110 | 845 m | |
| | | t | 6 | 4,5 | 3 | 1,5 | 0,2 | 12 | 9 | 6 | 3 | 1 | | |
| | 6 DVF 4 Optima | m/min | 0 → 50 (12 t) 0 → 100 (6 t) 0 → 120 (3 t) | | | | | 5,5 | 4 | | | | | |
| | RVF 162 Optima+ | tr/min U/min rpm | 0 → 0,8 | | | | | 2 x 7,5 | 2 x 5,5 | | | | | |
| | | | | | | | | | | | | | | |

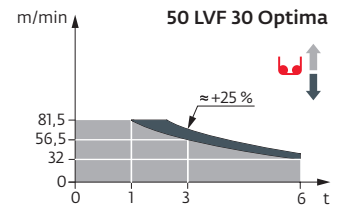

| 400 V (+10% -10%) 50 Hz | 50 LVF : 58 → 38 kVA 75 HPL™ : 78 → 48 kVA |
|-------------------------|---|

| | FR | DE | EN | ES | IT | PT | RU |
|--|--|--|---|---|---|--|---|
| | Profil de vent suivant EN 14439 C50-D50 | Windbedingungen gemäss EN 14439 C50-D50 | Wind conditions according to EN 14439 C50-D50 | Conformidad de los condiciones de viento EN 14439 C50-D50 | Condizioni del vento secondo EN 14439 C50-D50 | Perfil de vento conforme EN 14439 C50-D50 | Ветровой режим в соответствии с EN 14439 C50-D50 |
| | Appel de flèche | Auslegerüberhöhung | Jib elevation | Elevación de la flecha | Inclinazione braccio | Desvio da lança | подъем стрелы |
| | Équipements standards | Standardausrüstungen | Standard equipment | Equipamiento de serie | Equipaggiamento standard | Equipamento de série | Стандартное оборудование |
| | Équipements optionnels | Sonderausrüstungen | Options | Equipamiento opcional | Equipaggiamento in opzione | Equipamento opcional | Дополнительное оборудование (опция) |
| | Fonction Potain Plus : Courbes de charges Plus | Funktion Potain Plus: Plus-Lastkurven | Potain Plus function: Plus load curves | Función Potain Plus: Diagrama de cargas Plus | Funzione Potain Plus: Curve di carico Plus | Função Potain Plus: Diagrama de cargas Plus | Функция контроля мощности Potain Plus: Диаграммы грузоподъемности Plus |
| | Hauteurs sous crochet associées aux courbes de charges Plus | Hakenhöhen mit Plus-Lastkurven | Hook heights with Plus load curves | Altura bajo gancho, usando el diagrama de cargas Plus | Altezze sotto gancio con curve di carico Plus | Altura livre, utilizando o diagrama de cargas Plus | Высота под крюком для диаграмм грузоподъемности Plus |
| | Réactions en service | Reaktionskräfte in Betrieb | Reactions in service | Reacciones en servicio | Reazioni in servizio | Reacções em serviço | Реакция при работе |
| | Réactions hors service | Reaktionskräfte außer Betrieb | Reactions out of service | Reacciones fuera de servicio | Reazioni fuori servizio | Reacções fora de serviço | Реакция в покое |
| | Poids total du lest | Ballast-Gesamtgewicht | Total ballast weight | Peso total del lastre | Peso totale della zavorra | Peso total do lastro | Общий вес балласта |
| | Poids de flèche | Auslegergewicht | Jib weight | Peso de flecha | Peso del braccio | Peso da lança | вес стрелы |
| | Camion 13,4 m | Lkw 13,4 m | Lorry 13,4 m | Camión 13,4 m | Camion 13,4 m | Camião 13,4 m | Рзровой автомобиль 13,4 м |
| | Conteneur High Cube 40', et/ou Flat Rack 20' | Container High Cube 40', und/oder Flat Rack 20' | Container High Cube 40', and/or Flat Rack 20' | Contenedor High Cube 40', y/o Flat Rack 20' | Contentor High Cube 40', e/o Flat Rack 20' | Contentor High Cube 40', e/ou Flat Rack 20' | 40-футовый контейнер повышенной вместимости High Cube, и/или 20-футовая открытая платформа Flat Rack |
| | Levage | Heben | Hoisting | Elevación | Sollevamento | Elevação | Подъем |
| | Distribution | Katzfahren | Trolleying | Distribución | Ditribuzione | Distribuição | Перемещение по стреле |
| | Orientation | Schwenken | Slewing | Orientación | Rotazione | Rotação | Поворот |
| | Translation | Kranfahren | Travelling | Traslación | Traslazione | Translação | Перемещение крана |
| | Puissance requise | Erforderliche Leistung | Required power | Potencia Necesaria | Potenza richiesta | Potência Necessária | Потребляемая мощность |
| | Fonction Power Control : vitesses treuils adaptés à la puissance disponible | Funktion Power Control: Geschwindigkeiten der Triebwerke werden an die verfügbare Leistung angepasst | Power Control Function: winch speeds adapted to the available power | Función Power Control: marchas de los cabrestantes adaptadas a la potencia disponible | Funzione Power Control: velocità degli argani adattate alla potenza disponibile | Função Power Control: velocidades de guincho adaptadas à potência disponível | Функция контроля мощности Power Control: регулировка скорости лебедок в зависимости от доступной мощности |
| | Nous consulter | Auf Anfrage | Consult us | Consultarnos | Consultateci | Consultar-nos | Проконсультируйтесь у нас |
| | Document commercial non contractuel. Pour toute information technique se référer à la notice correspondante. | Unverbindliches Vertriebsdokument. Für technische Informationen, siehe die entsprechenden Anweisungen. | This commercial document is not legally binding. For any technical information, please refer to the corresponding instructions. | Documento comercial no contractual. Para cualquier información técnica, ver la noticia correspondiente. | Documento commerciale non vincolante, per tutte le informazioni tecniche fare riferimento al catalogo istruzioni. | Documento comercial não contratual. Para qualquer informação técnica complementar consultar as respectivas instruções. | Этот коммерческий документ не является юридически обязательным. Для получения технической информации, см. соответствующие инструкции. |

