

AK50

PHOTOELECTRIC ABSOLUTE ROTARY ENCODER



Absolute single turn rotary encoder AK50 is designed to be used in rotary tool changers, it features 8 bit gray or binary code outputs with arbitrary zero position, direction and resolution selection (set via switches), diagnostic facilities (status LED).

Encoder has the following features:

Ability to set arbitrary reference position (accessible via switch).

User selectable number of indexed positions accessible via switch (example: when used in a tool turret with different number of tools) with maximum of 256.

Following diagnostic facilities are provided via two bicolour LEDs:

1. Power supply failure
2. Internal failure (illumination failure, parity error)
3. Reference position indication

MECHANICAL DATA

Maximum shaft speed without counting loss for 8 bit	3000 rpm
Maximum shaft load:	
- axial	80 N
- radial (at shaft end)	100 N
Starting torque at 20 °C	3 Ncm
Rotor moment of inertia	20 gcm ²
Protection (IEC 529):	
- housing	IP66
- shaft	IP65

Maximum weight without cable	0.3 kg
Operating temperature	-20...+80 °C
Storage temperature	-30...+90 °C
Maximum humidity (non-condensing)	98 %
Permissible vibration (55 to 2000 Hz)	≤ 100 m/s ²
Permissible shock (11 ms)	≤ 1000 m/s ²

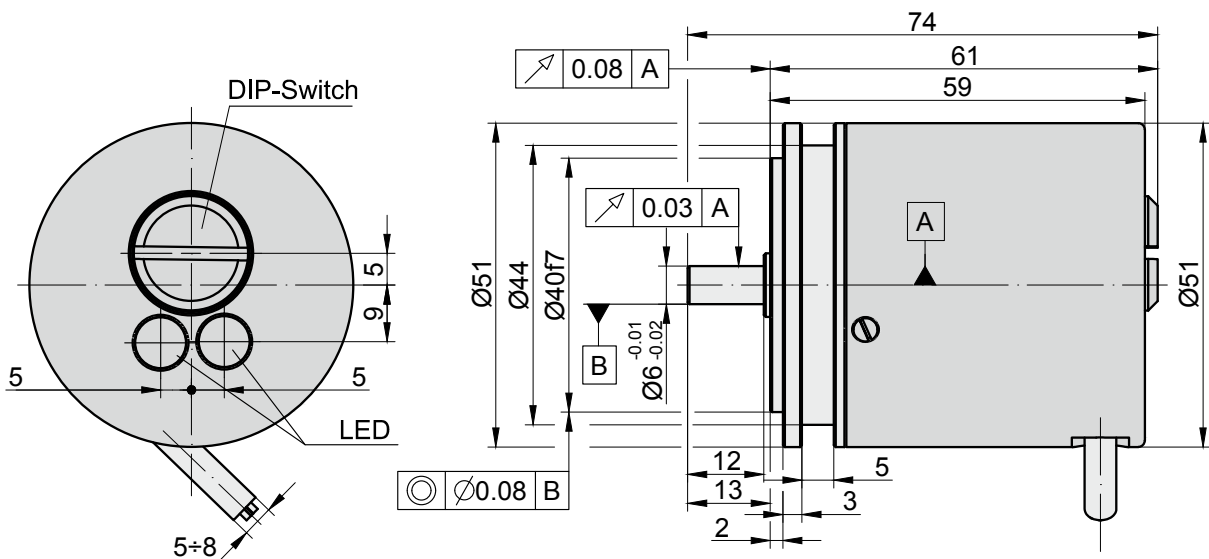

ELECTRICAL DATA

Accuracy	±120 arc. sec
Resolutio	2 ⁸ (256)
Code:	Gray, Binary, Other (custom)
Output signals interface	Parallel
Light source	LED
Supply voltage:	+24 (8...25) V± 5%
- standard	+5 V± 5%
- optional	
Maximum supply current	50 mA
Output signal levels	TTL/HTL
Maximum cable length	25 m

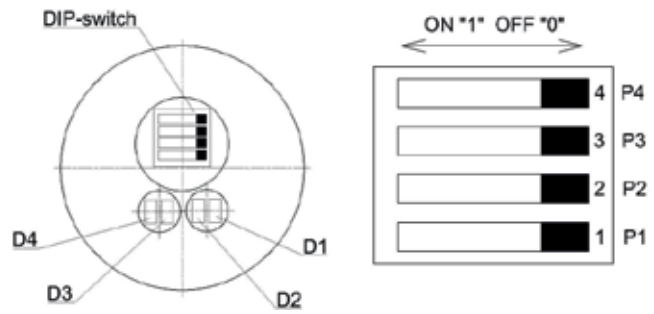

P1, P2, P3, P4 - operating mode and first setting switches;
D1 - green LED for indication of counting origin on code disc;
D2 - yellow LED for indication of specified counting origin;
D3 - red LED for indication of encoder failure:
- incorrect supply voltage,
- counting error,
- LED failure;
D4 - green LED for indication of proper encoder operating



Switches position depending on tool number in tool changer

Tool number in tool changer	Switch P1 position	Switch P2 position
8	0	0
12	0	1
16	1	0
24	1	1

Encoder code full truth table (24 positions)

Function	Indexing position of turret																							
	1	2	3	4	5	6	7	8	9	10	11	12	13	14	15	16	17	18	19	20	21	22	23	24
Strobe	1	1	1	1	1	1	1	1	1	1	1	1	1	1	1	1	1	1	1	1	1	1	1	1
1 Bit	1	0	1	0	1	0	1	0	1	0	1	0	1	0	1	0	1	0	1	0	1	0	1	0
2 Bit	0	1	1	0	0	1	1	0	0	1	1	0	0	1	1	0	0	1	1	0	0	1	1	0
3 Bit	0	0	0	1	1	1	1	0	0	0	0	1	1	1	1	0	0	0	0	1	1	1	1	0
4 Bit	0	0	0	0	0	0	0	1	1	1	1	1	1	1	1	0	0	0	0	0	0	0	0	1
5 Bit	0	0	0	0	0	0	0	0	0	0	0	0	0	0	0	1	1	1	1	1	1	1	1	1
Parity-check	1	1	0	1	0	0	1	1	0	0	1	0	1	1	0	1	0	0	1	0	1	1	0	0

ACCESSORIES

CONNECTORS FOR CABLE	B12 12-pin round connector	C9 9-pin round connector	C12 12-pin round connector	D9 9-pin flat connector	D15 15-pin flat connector	RS10 10-pin round connector	ONC 10-pin round connector
COUPLING	SC30						

ORDER FORM

CONFIGURATION TYPE:	NUMBER OF POSITIONS:	(OR) NUMBER OF BITS:	OUTPUT CODE:	SUPPLY VOLTAGE:	CABLE LENGTH:	CONNECTOR TYPE:	COUPLING:
P - POSITION NUMBER B - BIT NUMBER	2 ... 256 *only for AK50-P	1 2 ... 8 *only for AK50-F	G - gray B - binary O - other	05V - +5V 24V - +(8...25)V	AR01 - 1m AR02 - 2m AR03 - 3m ...	W - without connector B12 - round, 12 pins C9 - round, 9 pins C12 - round, 12 pins D9 - flat, 9 pins D15 - flat, 15 pins RS10 - round, 10 pins ONC - round, 10 pi	0 - without 1 - with coupling
ORDER EXAMPLES:	1) AK50-P-8/12/16/24-G-24V-AR01/W-1 2) AK50-B-8-G-05V-AR02/W-0 3) AK50-P-16/32-B-05V-AR12/C12-0 4) AK50-B-5/6/8-G-24V-AR06/W-1						