

ELEVATORI A TAZZE
BUCKET ELEVATORS
ÉLÉVATEURS À GODETS



SILESFOR 

www.silesfor.com



■ Gli **elevatori a tazze** vengono utilizzati nel trasporto verticale di cereali, prodotti granulari e sfarinati. L'intera serie EL viene realizzata con una finitura di zincatura a caldo su testa e piede, questo consente l'impiego all'aperto. Le canne possono essere fornite a scelta sia con zincatura a caldo che con zincatura in laminazione del tipo SENDZIMIR. Le tazze hanno un profilo ad alto rendimento e possono essere in ferro o PVC, mentre i nastri sono in gomma con rivestimento anti olio e antistatico. La trasmissione di serie avviene mediante motore, motoriduttore e cinghie; su richiesta è possibile avere trasmissione diretta.

■ *The **bucket elevators** are used for vertical transport of cereals, grain, flour products. The entire series EL is realized with dip galvanizing steel, that made this series suitable for outdoor uses. Also legs can be supplied on dip galvanized steel or SENDZIMIR galvanization. Buckets are made of iron or PVC with high efficiency form while belts are made of rubber, with mediately anti-oil and anti-static coating. Drive is made, on standard execution, by motor, anti-return reduction gear, belt drive; if required drive can be direct assembled on shaft.*

■ Les **élévateurs à godets** sont indiqués pour le transport vertical de céréales, de produits granulaires et farines. La totalité de la série EL est réalisée en tôle en acier zingué à chaud sur tête et pied ceci permet l'utilisation à l'extérieur. Aussi les jambes peuvent être fournis en tôle en acier zingué à chaud ou galvanisé SENDZIMIR. Godets sont en fer ou PVC avec profile à haut rendement, alors que bande en caoutchouc présente un revêtement médiamment anti-huile et antistatique.

MOD.	A	B	C	D	E	F	x	y	Ø	T/h*
EL1	765	260	590	320	950	779	144	164	300	10÷20
EL2	945	315	750	366	1.167	970	184	204	400	30÷45
EL3	1.145	355	950	416	1.410	1.180	224	254	500	60÷75
EL4	1.345	405	1.110	466	1.756	1.370	264	304	600	80÷100
EL5	1.483	440	1.308	506	2.000	1.574	300	400	700	150÷200
EL6	1.488	560	1.430	660	2.200	1.500	360	550	760	250÷300

Mais	peso specifico	780 kg/m ³	umidità	15%
Corn	specific weight	780 kg/m ³	moisture	15%
Mais	pois spécifique	780 kg/m ³	humidité	15%

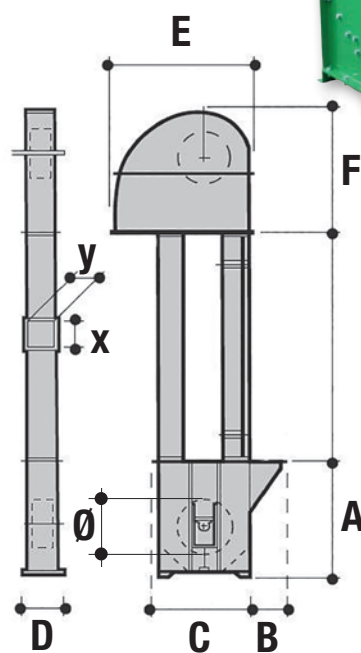

Silesfor DP s.r.l.
 Via Pitagora, 45 - 35030 Rubano - (PD) - ITALY
 Tel. +39 049 897 69 83 - Fax +39 049 63 14 99
silesfor@silesfor.com - www.silesfor.com