

CBI2801224A ALL In One

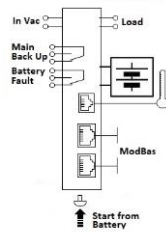

Input: Single-phase 115 - 230 - 277 Vac
 Output Selectable Load: 12 Vdc 15A; 24 Vdc 10A
 Output Battery charging: 12 Vdc 15A; 24 Vdc 10A
 Suited for the following battery types: Open Lead Acid, Sealed Lead Acid, lead Gel and Ni-Cd
 Automatic diagnostic of battery status. Charging curve IUUO, constant voltage and constant current Battery Life Test function (Battery Care)
 Four charging levels: Boost, Absorption, Float, Recovery
 Protected against short circuit and inverted polarity
 Signal output (contact free) for discharged or damaged battery
 Signal output (contact free) for mains or Back-UP
 Modbus RTU for all parameter battery and system
 Protection degree IP20 - DIN rail; Space saving

Technical features

Thanks to the All In One units (DC-UPS), it will be possible to optimize power management. The available power is automatically allocated between load and battery, supplying power to the load is the first priority of the unit thus it is not necessary to double the power, because also the power going to the battery will go to the load if the load so requires. The maximum available current on the load output is 2 times the value of the device rated current I_n . We call "Battery Care" the concept based on algorithms that implement rapid and automatic charging, battery charge optimization during time, flat batteries recovery and real time diagnostic during installation and operation. The Real Time Auto-diagnostic system, monitoring battery faults such as, battery Sulfated, elements in short circuit, accidental reverse polarity connection, disconnection of the battery, they can easily be detected and removed by help of Blink Code of Diagnosis Led; during the installation and after sell. The continuous monitoring of battery efficiency, reduces battery damage risk and allows a safe operation in permanent connection. Each device is suited for all battery types, by means of jumpers it is possible setting predefined curves for Open Lead Acid, Sealed Lead Acid, Gel, Ni-Cd (option). They are programmed for two charging levels, boost and charge, but they can be changed to single charging level by the user. A rugged casing with bracket for DIN rail mounting provide IP20 protection degree. They are extremely compact and cost-effective.

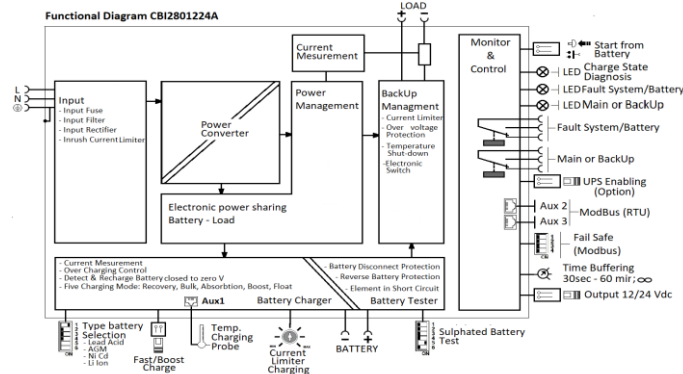

Norms and Certifications

In Conformity to: IEC/EN 60335-2-29 Battery chargers; cULus EN60950 / UL60950-1 and CSA C22.2 No. 60950-1-07 (Information Technology Equipment) – Safety – Part1: General Requirement. Electrical safety; EN54-4 Fire Detection and fire alarm systems; 89/336/EEC EMC Directive; 2014/35/UE (Low Voltage); DIN41773 (Charging cycle); Emission: IEC 61000-6-3; Immunity: IEC 61000-6-2. CE.

Climatic Data

Ambient temperature (operation)	-25 ÷ +70°C
De Rating $T^a > 50°C$	- 2.5% (In) /°C
Ambient temperature Storage	-40 ÷ +85°C
Humidity at 25 °C no condensation	95% to 25°C
Altitude: 0 to 2 000m - 0 to 6 560ft	No restrictions
Altitude: 2 000 to 6 000m - 6 560 to 20 000ft	De-rating 5°C/1000m
Cooling	Auto convention

General Data

Insulation voltage (IN/OUT)	3000 Vac
Insulation voltage (Input / ground)	1605 Vac
Insulation voltage (Output / ground)	500 Vac
Protection Class (EN/IEC 60529)	IP20
Reliability: MTBF IEC 61709	> 300.000 h
Pollution Degree Environment	2
Connection Terminal Blocks screw Type	2,5mm(24-14AWG)
Protection class (PE Connected)	I, with PE
Dimensions (w-h-d)	100x115x135 mm
Weight	0.85 kg

Input Data

Nominal Input Voltage Vac	115 – 230– 277
Voltage range Vac	90 – 135 180 – 305
Inrush Current ($V_n - I_n$ nom. Load) I ² t	≤ 16 A ≤ 5 msec.
Frequency	47 ÷ 63 Hz
Input Current (115 – 230 Vac)	3.3 – 2.2 A
Internal fuse (not replaceable)	6.3 A
External Fuse (recommended) MCB curve B	16 A

Output Data (internal power supply)

Select Output Voltage 12 or 24 Vdc.	By:	Jumper Enabling
Continuous current (without battery) Iload= In		In A

Continuous current (With battery) Iload= In+ I batt	2 x In
Max. current Output Load (Main) Iload (4 sec.)	3 x In max.
Max. current Output Load (Back Up) Iload (4 sec.)	2 x In max.
Start From Battery Without Main (Remote Input Control)	RTCONN (cable) Push Button
Time Buffering; min (switch output off without main input)	0.5; 2.5; 10; 15; 20; 30; 45; 60; ∞
Efficiency (at 50% of rated current)	≥ 91 %
Residual Ripple	≤ 80 mVpp
Turn-On delay after applying mains voltage	1 sec. (max)
Start up with Strong Load (capacitive load)	Yes, Unlimited
Dissipation power load max (W)	28
Short-circuit protection)	Yes
Over Load protection	Yes
Over Voltage Output protection	Yes (typ. 35 Vdc)
Overheating Thermal protection	Yes

Load Output 24 Vdc (jumper selection)

Output voltage (at In)	22 – 28.8 Vdc
Nominal current In = Iload	10 A ± 5% In
Threshold alarm Battery almost flat	20 – 21 Vdc batt
Protections against total discharge	19 – 20 Vdc batt

Load Output 12 Vdc (jumper selection)

Output voltage (at In)	10 - 14.4 Vdc
Nominal current In = Iload	15 A ± 5% In
Threshold alarm Battery almost flat	10 – 11 Vdc batt
Protections against total discharge	9 – 10 Vdc batt

Battery Output

Output Voltage Battery	Follow Out Load
Boost charge (25 °C) (at In)	2.4 V/cell.
Max. Time Boost-Bulk charge (Typ. at In)	15 h
Min. Time Boost-Bulk charge (Typ. at In)	1 min.
Switch Configuration battery type (V cell)	2.23; 2.25; 2.27; 2.3;
Ni-Cd (optional); when Float Charging mode	NiCd: 1.5 (20 cell.)
Charging current max I batt	In ± 5%
Charging current limiting Iadj	10 ÷ 100 % / I batt
Recovery Charge 12V / 24V	2 – 10Vdc / 2 – 20Vdc
Reverse battery protection	Yes
Sulfated battery check	Yes (by Jumper)
Short circuit Element Detection	Yes
Quiescent Current on the battery	≤ 5 mA
Charging Curve automatic: IUUO	4 stage
Remote Input Control (RTCONN cable)	Boost /Float
Threshold alarm Battery almost flat 12V / 24V	10 – 11 / 20 – 21 Vbatt
LVD. (Protections against total Batt. discharge) 12V / 24V	9 – 10 / 19 – 20 Vbatt

Signal Output (free switch contacts)

Main or Backup Input Power	Yes
Low Battery	Yes
Fault Battery or system	Yes

Type of Signal Output Contact

Dry Contact. Current can be switched (EN60947.4.1): Max: DC1: 30 Vdc 1 A; AC1: 60 Vac 1A (Resistive load) Min: 1mA at 5 Vdc (Min permissible load)

Fault System / Low Battery	C	NC	NO
Main or Back Up	C	NC	NO

Signal Input / Output (RJ45)

Temp. Comp. Battery (with external probe)	RJ Temp (cable) Aux 1
Remote monitoring data:	RJ 45 Aux 2 – Aux 3
Protocol:	Modbus RTU
UPS Disabling	Yes (RTCONN cable)