

SCREW JACKS

DESIGN GUIDE



INTRODUCTION

Duff-Norton has been manufacturing linear actuation products since 1883. We have earned a reputation for reliable, high quality products meeting the industrial lifting and positioning needs of our customers worldwide. Duff-Norton has been ISO 9001 registered since 1994.

NOTE

Duff-Norton has made every effort to ensure that the information contained in the publication is accurate and reliable. Determining the suitability of our products for specific applications is the user's responsibility.

WARNING

The equipment shown in this catalog is intended for industrial use only and should not be used to lift, support, or otherwise transport people unless you have written statement from Duff-Norton, which authorizes the specific actuator used in your applications as suitable for moving people.

TABLE OF CONTENTS

Introduction	2
Applications	5-9
Actuator Selection Guide	10-12
Application Analysis Forms	13-14
Imperial Machine Screw Actuators	
Features and specifications	15-17
Dimensional drawings	18-36
Stainless Steel Actuators	
Features, Model Numbers, Performance Specification	37-39
Dimensional Drawings	40-42
Anti-Backlash Actuators	
Features, Model Numbers, Performance Specification	43-46
Dimensional Drawings	47
Anode Jacks	48-49
Micro-Miniature Actuators	50
Imperial Ball Screw Actuators	
Features, Model Numbers, Performance Specification	51-53
Dimensional Drawings	54-71
Continuous Duty Actuators	
Features, Model Numbers, Performance Specification	72-74
Dimensional Drawings	75-77
Metric Machine Screw Actuators	
Features, Model Numbers, Performance Specification	78-80
Dimensional Drawings	81-89
Metric Anti-Backlash Actuators	
Features, Model Numbers, Performance Specification	90
Dimensional Drawings	91
Engineering Guide	
Frequently Asked Questions	92-96
Flange Bolt Information	97
Overhung Load Ratings	98
Lateral Movement Ratings	99
Worm Shaft Rotation Chart	100
Screw Column Strength	101-104
Ball Screw and Nut Life Rating	105
Power Actuator Gear Reducer Driven	
Features, Model Numbers, Performance Specification	106-112
Dimensional Drawings / Positions	113-114
Power Actuator C-Face Driven	
Features, Model Numbers, Performance Specification	116
Dimensional Drawings	117
B-Face Adaptors	118-119
Power Actuator HandWheels	
Features, Model Numbers, Performance Specification	120
Actuator Controls	
Control Panels	121-123
Rotary Limit Switches	124-126
Potentiometer/Transducer	127
Digital Position Indicator (Potentiometer)	128
Encoder - Worm Shaft	129
Encoder - Ring Kit	130
Digital Position Indicator (Encoders)	131
Magnetostrictive Position Sensor	132
Rotary Counters	133
Power Transmission Components	
System Arrangements, Component Selection Guide	134-136
Miter Boxes	137-139
Couplings (Chain, Jaw, Gear)	140-141
Connecting Shafts	142-143
Pillow Blocks	144
Flange Blocks	145
Bellows Boots	146-147
Inverted machine screw actuators	148
Terms of sale	150

WHAT'S NEW

New and Improved

- **B series actuators** – Duff Norton has re-engineered several existing models keeping both customer preferences and performance improvements in mind. In most cases, new drop in equivalents are now available. In a few cases minor dimensional differences exist, but do so with performance improvements in mind. Please see pages: 18, 19, 24, 54 for more information.
- **Expanded actuator worm / gear ratio options** - throughout our standard machine screw, stainless steel, and anti-backlash offerings; we now have expanded our gear set options to make it easier for our customers to achieve their desired performance parameters without involving secondary gearing. Please see pages 17, 39, 45 for more information.
- **Metric G series actuators** – Duff Norton now offers a comprehensive line up of european style metric actuators from 5kN to 500kN capacities. The G series offering includes both standard and anti-backlash models. These have become quite popular globally, and have the added benefit of dropping into the same spot as our traditional imperial actuators with minimal design adjustments. See pages 78-91.
- **IEC Motor adapters** – designed for our G series actuators, these include many of the most common IEC motor sizes. See pages 118-119.
- **Upgraded controls capabilities.** See pages 121-122.
- **Upgraded Magnetostrictive Position Sensing capabilities.** See page 132.



APPLICATIONS

Packaged Solutions, Countless Applications

Duff-Norton mechanical actuators, screw jacks and power transmission products are the best packaged solution for your linear actuation needs. With capacities ranging from 500 lb. to 250 tons, no one offers a broader range of solutions for your application needs. This extensive selection is designed to meet the requirements of the most challenging applications. Benefiting from the latest in advanced design techniques, manufacturing methods, and over 100 years experience, Duff-Norton Mechanical Actuators last longer and run smoother with little maintenance and no headaches. If you have a linear actuation application, Duff-Norton has the packaged solution for you.

Duff-Norton Customer Service Programs

Duff-Norton gives you the benefit of over a century of customer service. From stocking distributor programs, to expert application engineering, Duff-Norton is committed to providing you with the right solution every time. Our staff works hard to make sure you always get the product you need, when you need it.

The answer to all of your questions are always just a phone call away. Our Application Engineers and Customer Service Reps are ready to answer any question you may have about price, volume orders, availability or delivery. Additionally, there is always a District Sales Manager near you, ready to discuss your application and any special requirements you may have. Duff-Norton's Application Engineers will apply their years of experience to determine the right product to fit your needs, or to design a complete system to fulfill all of your requirements. This saves you time and money in the design, specification, procurement and installation of system components. Also, please visit our website and design your system online with our 3-D modeling software.

Whether you need a packaged solution, or one that has been custom designed to fit your specifications, Duff-Norton offers the expertise that comes from working closely with our worldwide customers. Combined with this history is a commitment to technology. We strive to constantly improve our manufacturing methods and stay ahead of industry trends in both our products and our philosophies. This comprehensive approach to customer service makes Duff-Norton actuators an exceptional value; we are always aware that we must provide the right solution every time.

Next time you have a linear motion need, call Duff-Norton first. Our Customer Service staff will take it from there!

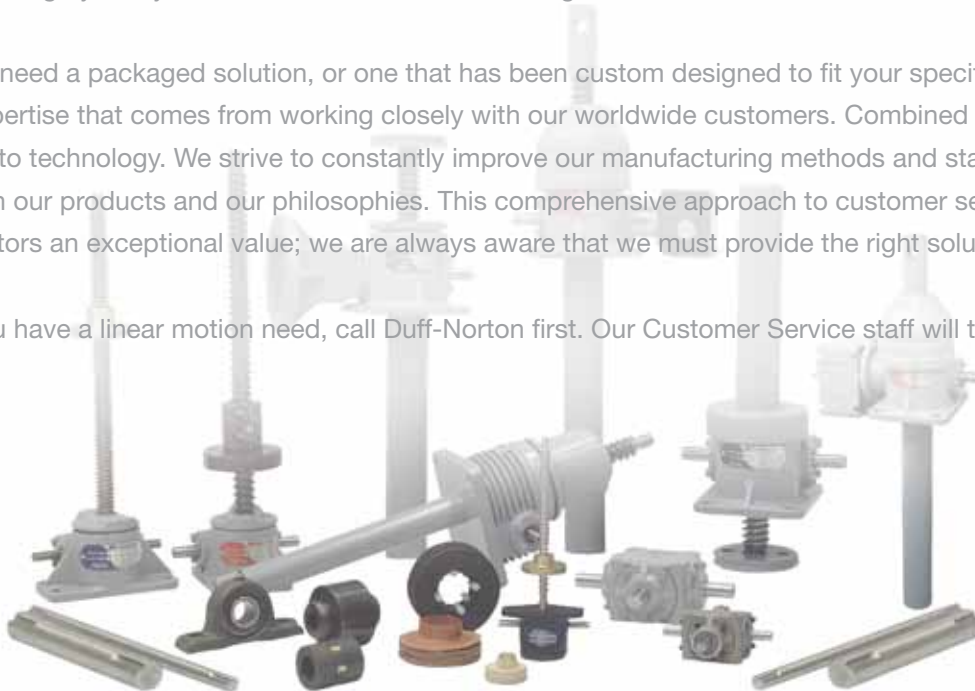

APPLICATIONS

Large satellite dish antenna movement (x, y, z axis)
Workplace table adjustments
Drive wheel adjustment to change conveyor flow stops
Conveyor lifts, diverters
Knife blade filter drum skimmer
Furnace combustion gun adjustment
Mechanical clutch linkage
Vacuum furnace lid lifters
Roll lifts
Mandrel pushers sluice gates
Low temperature valve operators
Unwind stands
Calender stacks
High voltage switch gear die set tables
Electron beam adjustments
Horizontal presses
Saw blade tension
Stage lifts for scenery changes
Robotics manipulator
Disc refiner blade adjustment
Blast door locks

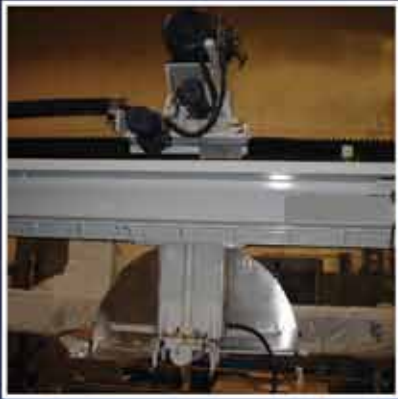

APPLICATIONS

Headbox unit for paper machine
Tooling machine bed adjustment
Textile, steel, rubber, plastics skewing roll adjustments
Pinch valve control actuation, gate and ball valve
Tension testing machines
Packaging machinery
Diagnostic scanners
Work platforms
Injection molding machines-head adjustment
Mechanical brake linkage adjustment
Curing processes-constant speed
Feed rate movement
Air dampers
Sheet slitter
Angle tilt adjustments with double clevis models
Remote contamination lifts
Precision closures
Solar panel actuation
Tension adjustment of cables
Welding positioners
Centerless grinder positioner
Locking indexing pins
Batch control
Palletizer indexing
Oven lifters
Door openers



SELECTION GUIDE

1. Define the application's operating parameters:

- Total load
- Load per actuator (if more than one is required)
- Desired lifting speed
- Travel (distance to move the load)
- Load type (tension, compression, guided, unguided)
- Ambient temperatures (-20° to 120°F, -29° to 50°C)

2. Determine which actuator type best suits the application:

Ball screw or machine screw? There are a wide variety of factors which influence the type of actuator selected. When comparing the two actuator types at the same capacity level; ball screw actuators, being much more efficient, require less motor horsepower to move the same load than do the equivalent machine screw actuators. However, many machine screw actuators are inherently load holding, offer a broader capacity range and a greater selection of special features or materials. Machine screw actuators are often favored in applications subject to constant vibration.

Ball Screw Actuator



- Continuous Duty models available
- Anti-Rotation models available, contact the factory for details
- Move loads and apply force more efficiently than machine screw actuators
- Require less power by reducing screw friction
- Permit faster operation and longer life under load
- Long predictable ball screw and ball nut life
- Handles full load in tension or compression

Machine Screw Actuators



- Anti-backlash models available for 1/4 to 150 Ton capacities
- Stainless steel and metric models available for most capacities
- Precise positioning within thousandths of one inch
- Self locking - models featuring higher gear ratios are inherently load holding as long as the actuator is not subject to vibration
- Uniform lifting speeds - since many actuators feature the same gear ratios different capacities can be used in the same application to lift unevenly distributed loads with uniform speeds

3. Calculate actuator performance:

Find an actuator model with Capacity greater than the actuator load. Go to the applicable Actuator Performance Specification table and find Turns of Worm for 1" Raise, Worm Torque at No Load, and Worm Torque at Full Load.

A. For loads greater than 25% of actuator capacity, consider torque to be proportional to load:

$$\text{Actuator torque(in-lb)} = \frac{\text{Actuator Load(lbs)} \times \text{Worm Torque at Full Load}}{\text{Actuator Capacity (lbs)}}$$

For loads less than 25% of actuator capacity, add "Worm torque at no load" to the above calculated torque, to account for frictional losses.

B. Calculate input RPM. Shaft input should not exceed 1800 rpm.

$$\text{Input RPM} = \text{Desired Lifting Speed(in/min)} \times \text{Turns of Worm for 1" Raise}$$

C. Calculate actuator input HP.

$$\text{Actuator Input HP} = \frac{\text{Actuator torque(in-lb)} \times \text{rpm}}{63,000}$$

USERS GUIDE FOR SELECTING A MECHANICAL ACTUATOR

Compare required Input HP to the Maximum HP per Actuator shown in the Performance Table. If Required HP exceeds Maximum HP, an actuator with greater HP rating must be chosen to obtain the speed and capacity rating desired.

If using a gear reducer, motor horsepower must be multiplied by reducer efficiency to obtain reducer output (actuator input) horsepower.

D. Multiple actuator arrangements:

Two or more actuators are often shaft driven from one motor or gear reducer. For multiple actuator arrangements, sum the input HP requirement of all actuators. If using mitre gear boxes, allow for 2% power loss through each 90° turn in the power path.



Upright Translating



Inverted translating



Upright Rotating



Inverted Rotating

4. Determine the actuator configuration:

Considering capacity, speed, and duty cycle requirement, select the actuator type and configuration which most closely matches your application's configuration requirements.

5. Un-attached or un-guided load considerations:

If your application involves a load which is un-attached or the load is free to rotate, the translating screw actuator must be configured so that the lifting screw will extend when the actuator is in motion. To prevent the translating screw from rotating, machine screw actuators are supplied with a keyed shell and screw, and ball screw actuators are supplied with a square nut on the lifting screw's end, inside a square cover pipe. Both of these configurations ensure the actuator will properly perform for this type of application.



Anti-Rotating Ball Screw

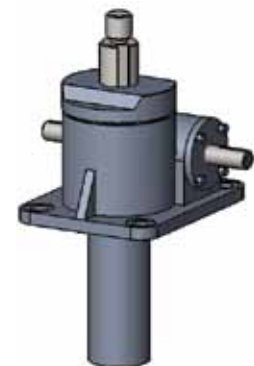

Keyed Machine Screw

SELECTION GUIDE

6. Verify the actuator selection:

Double check your application's travel requirements, and the actuator's ratio. Verify the actuator's capacity and speed. Also, determine which of the following actuator end fittings best suits your application's requirements.



Top Plate



Clevis End



Threaded End

Please see pages 92-105 for more detailed engineering information such as:

- Flange bolt information
- Overhung loads
- Lateral movement ratings
- Screw column strengths

Note

Please refer to our "Column Strength Charts" (pages 101-104) if the lifting screw is loaded in compression. It may be necessary to select a larger actuator if the maximum recommended screw length, regardless of load, or maximum load has been exceeded.

Note

As duty cycles are intermittent, there is an inverse relationship regarding an actuators maximum duty cycle and the load being moved. Please consult our application engineers for assistance in determining the most appropriate actuator.

WARNING

- Input RPM should not exceed 1800 RPM.
- Never exceed the actuator's static and dynamic capacity.
- Never exceed the horsepower listed in our actuator specification tables. If the maximum horsepower recommendation is exceeded, reduce the lifting speed, use a larger capacity actuator, choose another actuator ratio, or consider a more efficient actuator type such as a Ball Screw or Continuous Duty Actuator.
- Ball Screw and Continuous Duty Actuators are inherently self-lowering. Should one of these models be the best fit for an application, a brake motor with sufficient torque is required. Please contact our application engineers for assistance.

Screw Jack Application Analysis Form

Duff-Norton engineers will be pleased to make recommendations for your specific requirements. Complete this form and mail or fax it to the Duff-Norton Company. There is no obligation for this service. Use a separate sheet to sketch your application, or send us your design drawings in complete confidence. P.O. Box 7010 • Charlotte, NC 28241-7010 • Ph: 800-477-5002 • Fax: 704-588-1994 • duffnorton@cmworks.com

Company: _____

Address: _____

Phone Number: _____ Fax Number: _____

Contact: _____

Email Address: _____

1. Type of application: _____

2. How many actuator units are needed? _____

3. Stroke (Raise) / Unit: _____ in. _____

4. How many mitre gear boxes are needed? _____

5. Total working load: _____ Working load per unit: _____

6. Total static load: _____ Static load per unit: _____

7. Side thrust on lifting screw: Yes No _____ lbs.

Off-center load on lifting screw: Yes No _____ in. / lbs.

8. Operating Cycles: _____ per hour _____ hours per day _____ days per week

9. Life expectancy: _____ in. (inches per cycle x cycles per hour x hours per day x days per years x years of service required)

10. Lifting speed desired: _____ in./min.

11. Are controls required for your system: Yes No

12. Drive: Manual Motor-driven

13. Mounting Position

Limit Switch (pg. 125) RH Side _____ (1, 2, 3, 4)

LH Side _____ (1, 2, 3, 4)

Reducer* (pg. 114) RH Side _____ (1, 2, 3, 4)

LH Side _____ (1, 2, 3, 4)

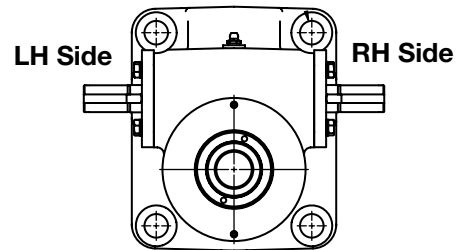

**(On select models this is required to allow for proper lubrication of the gearbox. Choose the option that most closely matches the actual installed position.)*

14. Load type: Guided Unguided Compression Tension Both compression & tension

15. Conditions: Vibration Impact Wet Corrosive Explosion Proof Other

16. Temp. Range: _____

17. Std. actuator model best suited to application: _____

18. Ultimate use of actuator units: In-plant Resale Lift people

19. Quotation desired on the following quantities: Total Per System

Screw Jack Controls

Duff-Norton engineers will be pleased to make recommendations for your specific requirements.

Complete this form and mail or fax it to the Duff-Norton Company. There is no obligation for this service.

Use a separate sheet to sketch your application, or send us your design drawings in complete confidence.

P.O. Box 7010 • Charlotte, NC 28241-7010 • Ph: 800-477-5002 • Fax: 704-588-1994 • duffnorton@cmworks.com

Company: _____

Address: _____

Phone Number: _____ **Fax Number:** _____

Contact: _____

Email Address: _____

1. Comments: _____

2. If the environment is explosive or hostile, where will the operator be located? _____

3. Motor Enclosure: Open Drip Proof Totally Enclosed Wash Down

4. Controls Enclosure: NEMA 1 NEMA 12/13 NEMA 4 NEMA 4X NEMA 3R

5. Motor Mounting: Separate C-Face Right Angle In Line Other _____

6. Additional Gearing: None In Line Right Angle Integra Ratio

7. Orientation (description): _____

8. Controls Mounting: Wall Floor Free Standing Pedestal Console Other _____

9. Control Requirements: _____ Volts _____ Phase _____ Hz

10. Operation: Variable Speed Constant Speed Multiple Speed Inch/Jog

Maintained Position Velocity Torque

11. Features: Soft Start; Acceleration Rate _____ in/min² Remote Control

Soft Start/Stop; Acceleration Rate _____ in/min²

Soft Start/Stop; Acceleration Rate _____ in/min²

Indicators (specify): _____

Alarms (specify): _____

Communication (specify): _____

Limit Switches (specify voltage & mounting position if mounted on actuator worm shaft extension): _____

Accuracy for positioning (in.): _____

Number of positions: _____

Velocity Regulation: _____

Duty Cycle (from above): _____

Acceleration and Deceleration rates (from above): _____

Line Shaft Accuracy: _____

Load Conditions (from above): _____

Duff-Norton Actuators most appropriate for this application: _____

Controls Needed: _____

MACHINE SCREW ACTUATORS

1/4 to 250 Tons

Because the Duff-Norton machine screw mechanical actuator is produced in many standard models with a wide range of capacities, there is a standard model for almost any requirement. Models can be furnished to 250 Tons capacity.

Operated manually or by means of gear motors, machine screw actuator models can be used singly, in tandem or in multiple arrangements (see page 133). Since most capacities have a uniform lifting speed, added economy can be realized in raising unevenly distributed loads by operating the different capacities in union.

Most Duff-Norton machine screw actuator models with higher ratios are self-locking and will hold heavy loads in position indefinitely without creep. They can be used to push, pull, apply pressure and as linear actuators. They are furnished with standard raises in increments of 1 inch. Depending upon size and type of load, models are available with raises up to 20 feet.

Top Plate

Must be bolted to lifting member to prevent rotation except when screw is keyed.

Lifting Screw

Available with threaded end or clevis end instead of top plate.

Shell Cap

Locked into place by set screws.

Load Bearings

Bearings, top and bottom to take loads in either direction.

Thrust Bearing & Grease Seals

At each end of worm. 1/4, 1/2 and 1-Ton models do not have seals.

Worm Gear

Wear resistant Bronze. Accurately hobbled for greater gear contact.

Worm

Available with double or single shaft extension.

Housing

Aluminum on 1/4 to 1-Ton models. Ductile iron or cast steel 2-Ton through 250-Ton models.

Coverpipe

Protects lifting screw threads.

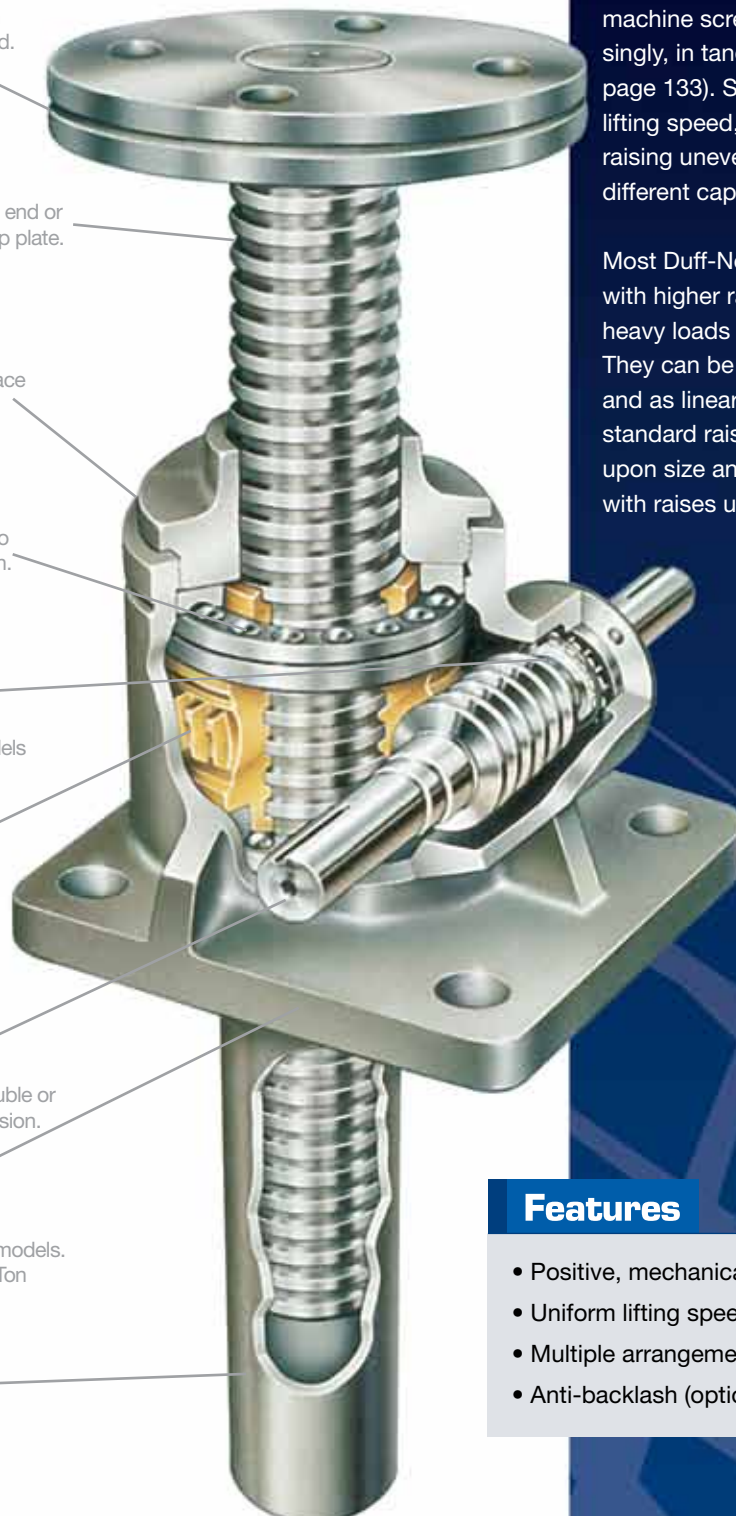

Features

- Positive, mechanical positioning
- Uniform lifting speed
- Multiple arrangements
- Anti-backlash (optional)

MACHINE SCREW ACTUATORS

Model Numbering System

FL - TKM - 9002 - 6 - 1R

Model Prefix

R - Reducer
F - C-face Adapter
H - Hand Wheel
L - Limit Switch
E - Encoder
J - Rotary Counter

Screw End & Configuration

T - Threaded End
C - Clevis End
M - Top Plate
P - Plain End
K - Keyed Screw
CC - Double Clevis
D - Inverted Rotating
U - Upright Rotating
N - Numeric Ratio

Series & Capacity No.

Series:

Machine Screw
 (90xx, 18xx, 70xx, 25xx)
 Special MS
 (100xx, 20xx, 80xx, 35xx)

(1800 series base configurations are available only on 2 and 50 Ton models)

Capacities:

Upright model suffixes end with the capacity number. Inverted model suffixes lower the capacity number by one digit. Rotating model suffixes raise the capacity number by one digit.

M - Base Model

Travel

1" increment travels are always represented using the exact travel amount.

Travels with fractional lengths are quoted using that length, but are serialized when the order is processed.

Serialized digits in this position may also be used for other models containing special features

Model Suffix

B - Boot
L - Single End Worm Ext. Left
R - Single End Worm Ext. Right
1 - Optional Ratio #1
2 - Optional Ratio #2
X - Supplied without cover pipe

B9003 TV - 10.50 - LX2 - BFL

Capacity

B9225 - 500 Lbs
B9250 - 1000 Lbs
B9003 - 3 Ton

Screw End

C - Clevis End Screw
CC - Double Clevis Ends
M - Top Plate Screw
P - Plain End Screw
T - Threaded End Screw

Travel

1" Incremental travels are always represented using the exact travel amount. Fractional lengths are represented and processed to the nearest 100ths.

Base Model

None - Upright Translating
D - Inverted Rotating
K - Keyed, anti-rotation
U - Upright Rotating
V - Inverted Translating

Key Accessories

B - Boot
E - Encoder
F - C-face Adapter
H - Hand Wheel
J - Rotary Counter
L - Limit Switch
R - Reducer

Model Suffix

L - Single End Worm Extension Left
N - Numeric Gear Ratio - 100 turns/inch
R - Single End Worm Extension Right
X - Supplied without Cover Pipe
1 - Alternate Gear Ratio #1
2 - Alternate Gear Ratio #2

Alphabet characters representing features and suffixes should always be used in alphabetic order to avoid questions of hierarchy.

Models for actuators with specialized features will have a serialized suffix such as B9225T-0001.

Machine Screw Actuator Performance Table

Performance Table Instructions – pgs. 17, 39, 45, 53 and 74

When reviewing any Duff-Norton Actuator Performance Specifications Table, as part of the process of selecting the best-suited actuator for your application, there are several important worm-gear ratios to consider.

Standard Ratio – is frequently chosen when higher speeds and efficiency ratings are desired.

Optional Ratio – is frequently chosen when the application requires higher lifting capacities, lower speeds, or to ease the use of a handwheel.

Numeric Ratio – is frequently chosen for applications requiring fine adjustments, higher lifting capacities, lower speeds, the easy use of a handwheel, self locking applications, and also offers the benefit of an even number of worm input turns per inch of stroke.

Specifications - Standard, Optional, and Numeric Ratios																	
Capacity (Tons)	1/4	1/2	1	2	3	5	10	15	20	25	35	50	75	100	150	250	
Max. Speed C-face Driven (in/min)** page 116	—	—	—	72.0	72.0	108.0	108.0	108.0	108.0	107.5	107.5	—	—	—	—	—	
Max. Speed Red. Driven (in/min)** page 108-109	—	—	—	14.4	21.9	21.9	21.9	21.9	21.9	22.2	22.4	12.2	—	—	—	—	
Dimensional Information Shown on page	18	19	20	21-23	24	25	26	27	28	29	30	31-32	33	34	35	36	
Lifting Screw	Diameter (in)	5/8	5/8	3/4	1	1	1 1/2	2	2 1/4	2 1/2	3	3 3/4	4 1/2	5	6	7	9
	Pitch (Std.&Opt.)	0.250	0.125	0.200	0.250	0.250	0.375	0.500	0.500	0.500	0.666	0.666	0.666	0.666	0.750	1.000	1.000
	Pitch (Numeric)	—	—	—	—	—	0.250	0.250	0.250	0.250	0.320	0.320	0.320	—	—	—	—
	Type	ACME	ACME	ACME	ACME	ACME	ACME	ACME	ACME	ACME	ACME	ACME	Mod. Sq.	Mod. Sq.	Mod. Sq.	Mod. Sq.	Mod. Sq.
Worm Gear Ratios	Std.	5:1	5:1	5:1	6:1	6:1	6:1	8:1	8:1	8:1	10 2/3:1	10 2/3:1	10 2/3:1	10 2/3:1	12:1	12:1	50:1
	Optional No. 1	—	—	20:1	24:1	24:1	24:1	24:1	24:1	24:1	32:1	32:1	32:1	32:1	36:1	36:1	—
	Optional No. 2	—	—	—	12:1	12:1	12:1	—	—	—	—	—	—	—	—	—	—
	Numeric Ratio	—	—	20:1	25:1	25:1	25:1	25:1	25:1	32:1	32:1	32:1	—	—	—	—	—
Turns of Worm for 1" Stroke	Std.	20	40	25	24	24	16	16	16	16	16	16	16	16	12	50	
	Optional No. 1	—	—	100	96	96	64	48	48	48	48	48	48	48	48	36	—
	Optional No. 2	—	—	—	48	48	32	—	—	—	—	—	—	—	—	—	—
	Numeric Ratio	—	—	100	100	100	100	100	100	100	100	100	100	—	—	—	—
Worm Torque at No Load (in-lb)	Std.	2	2	5	5	5	10	20	20	30	40	50	100	150	200	250	200
	Optional No. 1	—	—	5	5	5	10	20	20	30	40	50	100	150	200	250	—
	Optional No. 2	—	—	—	5	5	10	—	—	—	—	—	—	—	—	—	—
	Numeric Ratio	—	—	5	5	5	10	20	20	30	40	50	100	—	—	—	—
Maximum Horsepower per Actuator	Std.	1/3	1/3	1/2	2	2	4	5	5	8	8	15	15	25	25	35	
	Optional No. 1	—	—	1/4	1/2	3/4	3/4	1 1/2	1 1/2	1 1/2	2 1/2	2 1/2	6	6	11	11	—
	Optional No. 2	—	—	—	3/4	1 1/4	2	—	—	—	—	—	—	—	—	—	—
	Numeric Ratio	—	—	1/4	1/2	1/2	3/4	1 1/2	1 1/2	1 1/2	2 1/2	2 1/2	6	—	—	—	—
Worm Torque at Full Load* (in-lb)	Std.	13	21	55	120	165	450	750	1430	1811	2220	4000	7500	12000	16000	28110	20000
	Optional No. 1	—	—	25	50	75	185	400	820	1035	1401	2400	4200	6601	8600	15500	—
	Optional No. 2	—	—	—	75	105	275	—	—	—	—	—	—	—	—	—	—
	Numeric Ratio	—	—	25	48	72	175	370	640	925	1500	2411	4040	—	—	—	—
Efficiency Rating (%)	Std.	30.6	18.9	23.1	22.1	24.2	22.1	26.5	20.9	22.0	22.4	17.4	13.3	12.4	12.4	14.2	8.0
	Optional No. 1	—	—	12.7	13.3	13.3	13.4	16.6	12.1	12.8	11.8	9.7	7.9	7.5	7.7	8.6	—
	Optional No. 2	—	—	—	17.7	19.0	18.1	—	—	—	—	—	—	—	—	—	—
	Numeric Ratio	—	—	12.7	13.3	13.2	9.1	8.6	7.5	6.9	5.3	4.6	3.9	—	—	—	—
Key Torque (in-lb)	Std & Opt. 1 & 2	40	70	175	460	670	1750	4700	7580	10625	14000	26500	47110	73000	118200	216000	423300
	Numeric Ratio	—	—	175	460	670	1599	4077	6645	9369	11474	18561	30970	—	—	—	—
Max Worm Speed at Full Load (rpm)	Std.	1616	1000	573	1051	766	560	420	220	174	227	126	126	79	98	56	110
	Optional No. 1	—	—	630	630	631	278	236	115	91	112	66	90	57	81	45	—
	Optional No. 2	—	—	—	630	751	458	—	—	—	—	—	—	—	—	—	—
	Numeric Ratio	—	—	630	657	437	270	256	148	102	105	65	94	—	—	—	—
Max Load at Full Horsepower and 1750 rpm (lb)	Std.	455	527	520	2332	2521	3047	4386	3406	3370	5691	4220	5949	4939	8865	7003	26780
	Optional No. 1	—	—	400	1156	1888	1064	1791	1276	956	1839	1193	2831	1537	4670	2875	—
	Optional No. 2	—	—	—	1258	2402	2339	—	—	—	—	—	—	—	—	—	—
	Numeric Ratio	—	—	400	1210	1162	1031	1944	1646	1074	1714	1187	2946	—	—	—	—
Weight with 6" Stroke (Raise) (lb)	2	2	5	17	17	35	52	66	93	160	240	410	650	1200	1350	2700	
Weight per Additional 1" Stroke (Raise) (lb)	0.1	0.1	0.3	0.3	0.3	0.9	1.4	1.5	2.6	2.5	3.7	5.5	6.5	9.0	12.6	23.0	

*For loads from 25% to 100% of actuator capacity, torque requirements are approximately proportional to the load.

** Speed is a function of how the actuator is driven. Please see the indicated pages for more information.

Note: All actuator units can be supplied with standard raises up to 24 inches. Special raises up to 20 feet are available upon request. Closed height dimensions may increase for actuators supplied with bellows boots. See pages 146-147.

MACHINE SCREW ACTUATORS

500 lb Capacity

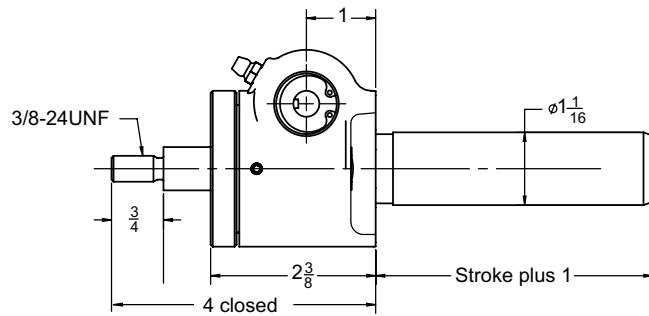
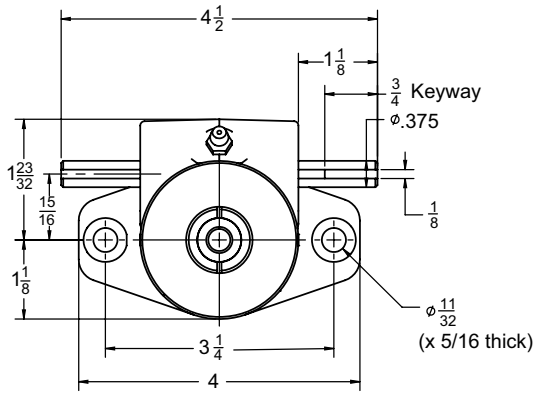

Upright: B9225T

5/8 Diameter x .250 Lead Lifting Screws

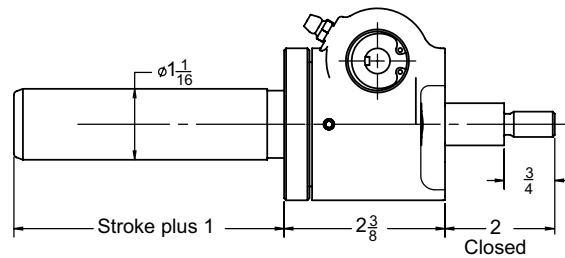
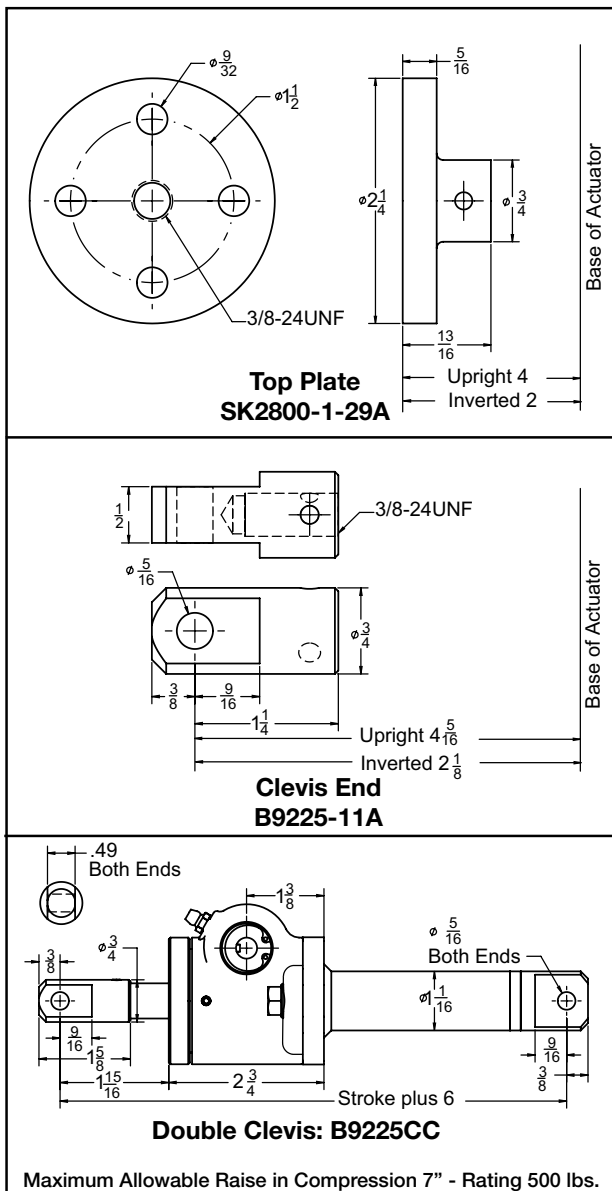

Inverted: B9225TV

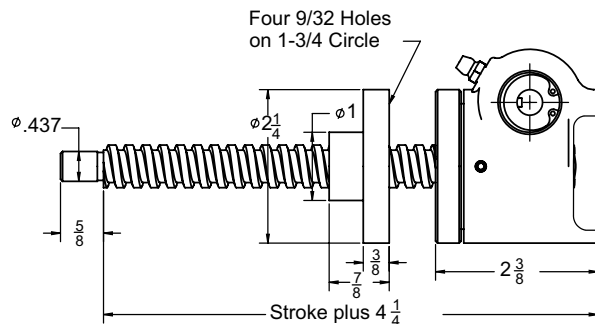

Upright Rotating: B9225U

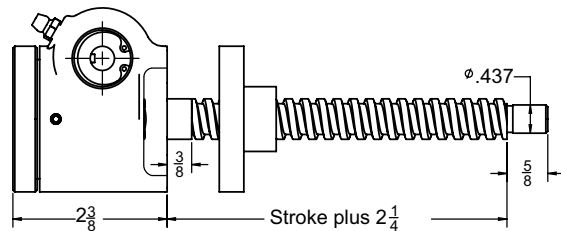

Inverted Rotating: B9225D

Note: Lifting screw is not keyed. Top should be secured to a lifting member to prevent rotation. When a Bellows Boot is required, see pages 146-147. Dimensions are subject to change without notice. When the lifting screw is keyed, the holes in the top plate will not necessarily be in the position shown.

1000 lb Capacity

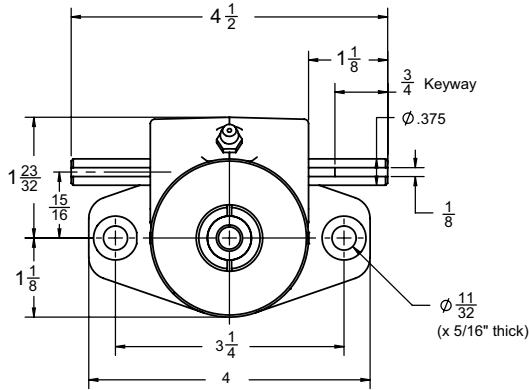

5/8 Diameter x .125 Lead Lifting Screws

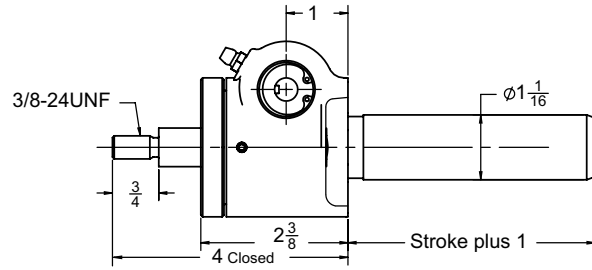

Upright: B9250T

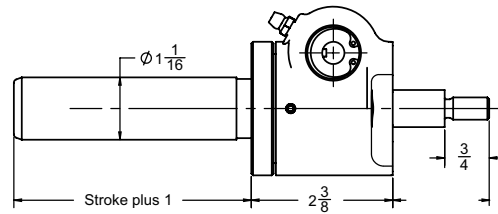
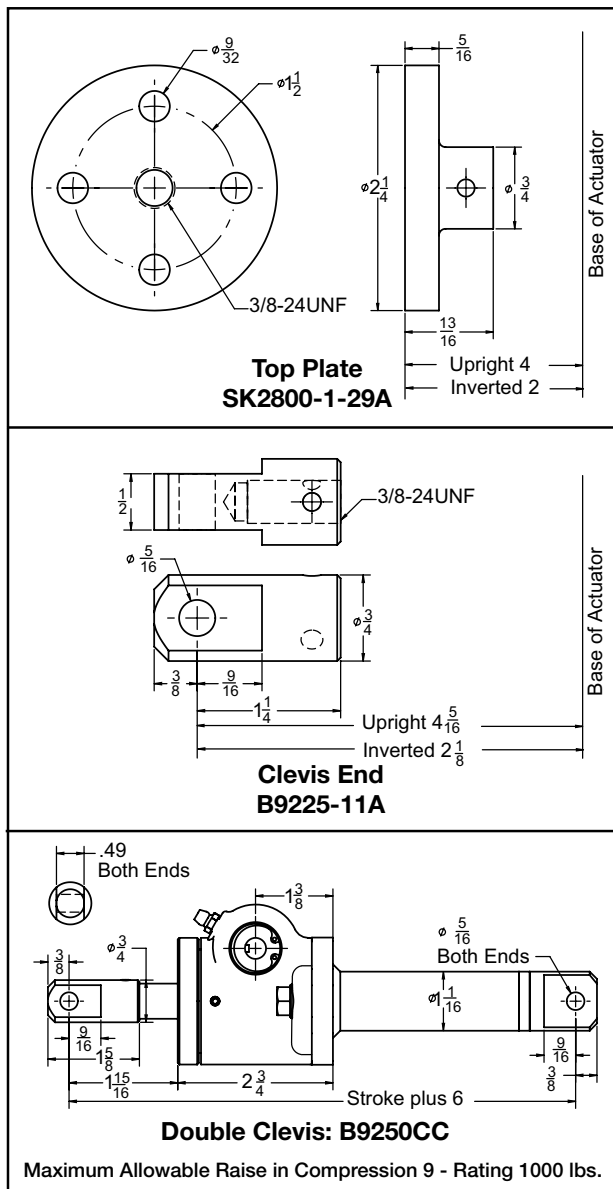

Inverted: B9250TV

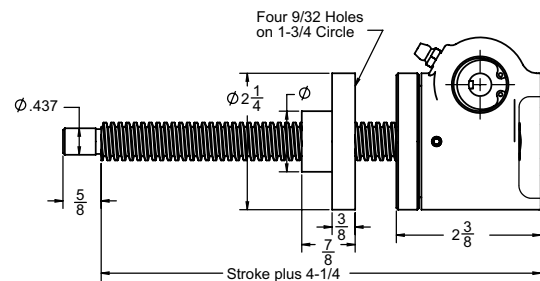

Upright Rotating: B9250U

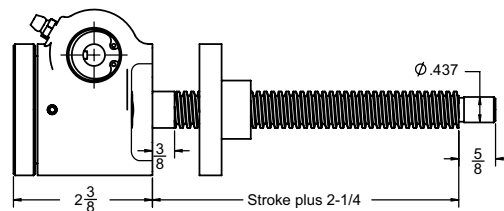

Inverted Rotating: B9250D

Note: Lifting screw is not keyed. Top should be secured to a lifting member to prevent rotation. When a Bellows Boot is required, see pages 146-147. Dimensions are subject to change without notice. When the lifting screw is keyed, the holes in the top plate will not necessarily be in the position shown.

MACHINE SCREW ACTUATORS

1 Ton Capacity

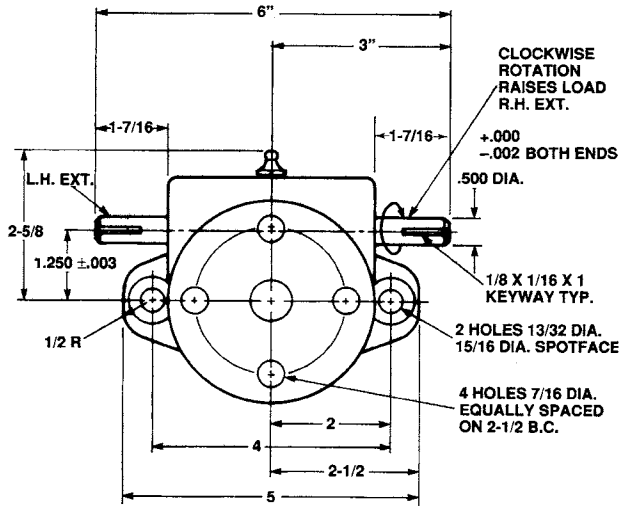

3/4" Diameter x .200 Lead Lifting Screws

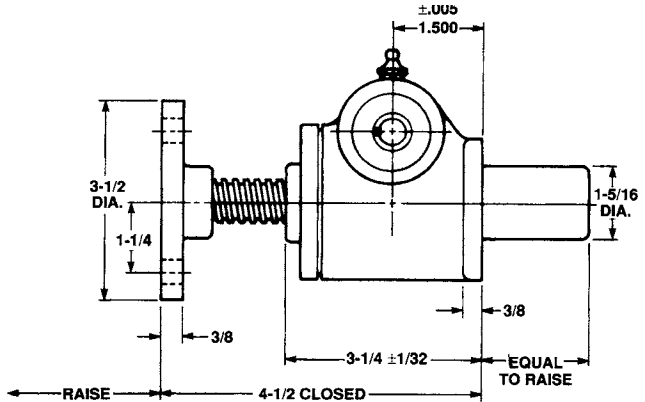

Upright: M-2501

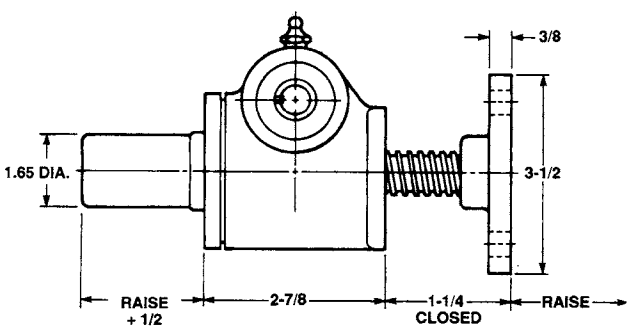

Inverted: M-2500

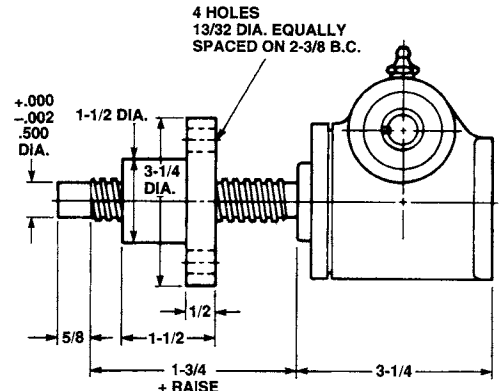

Upright Rotating: UM-2502

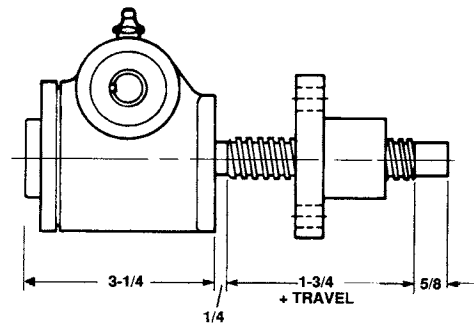

Inverted Rotating: DM-2502

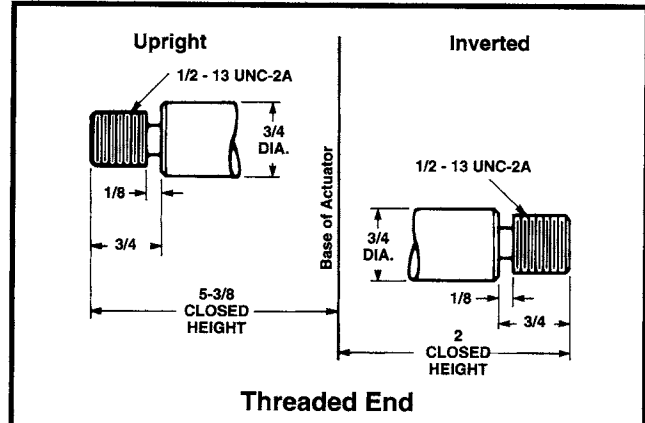

Threaded End

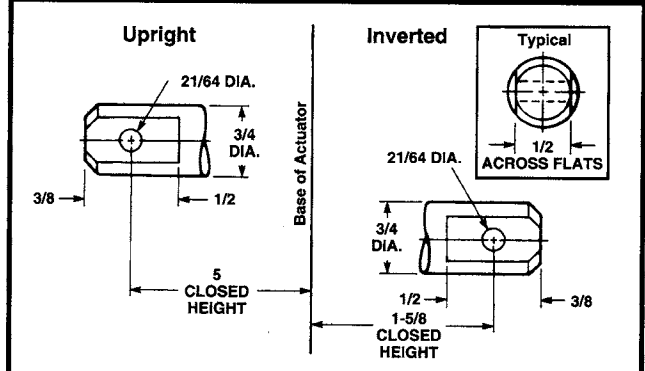

Clevis End

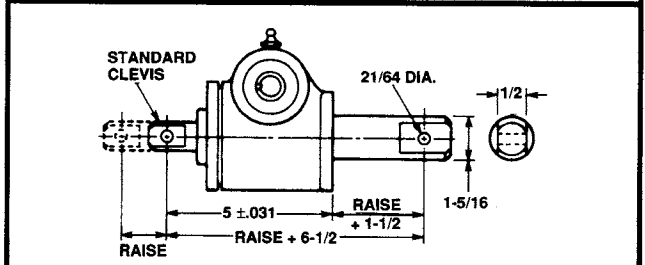

Double Clevis: CCM-2501

Maximum Allowable Raise in Compression 10" —Rating 1500 Lbs.
Maximum Raise at Rated Load in Compression 8"

Note: Lifting screw is not keyed. Top should be secured to a lifting member to prevent rotation. When a Bellows Boot is required, see pages 146-147. Dimensions are subject to change without notice.

2 Ton Capacity, 9000 Series

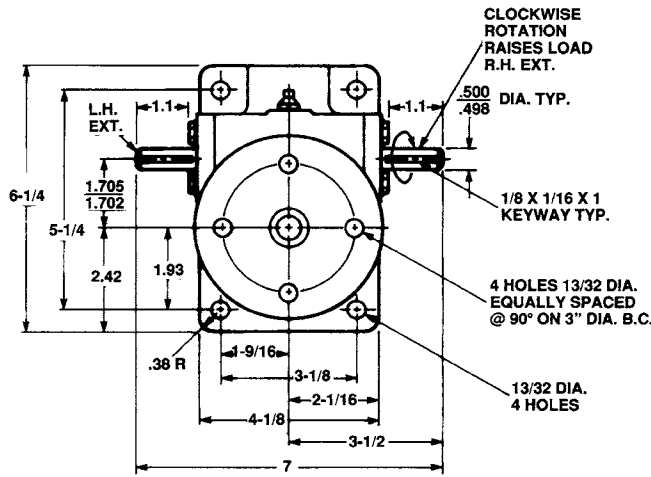

1" Diameter x .250 Lead Lifting Screws

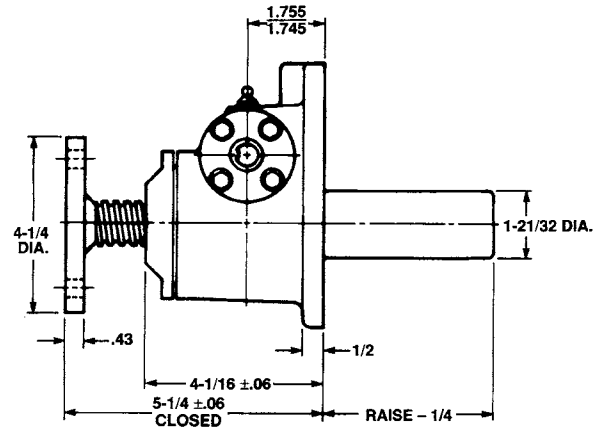

Upright: M-9002

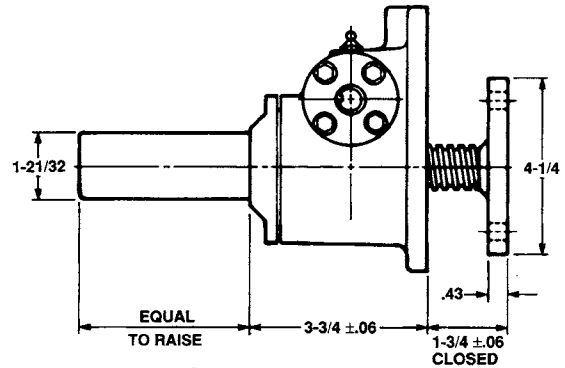

Inverted: M-9001

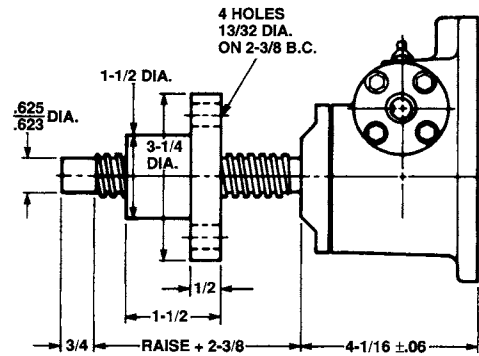
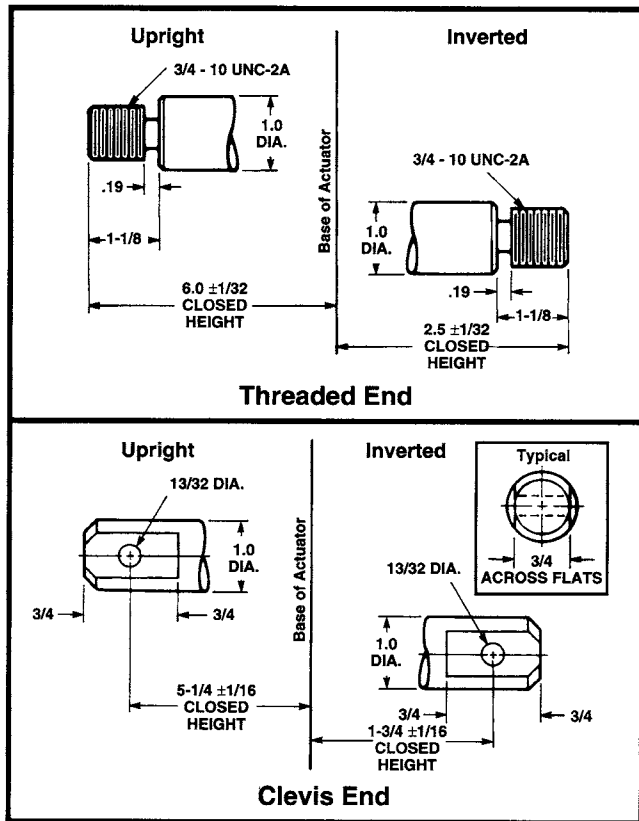

Upright Rotating: UM-9003

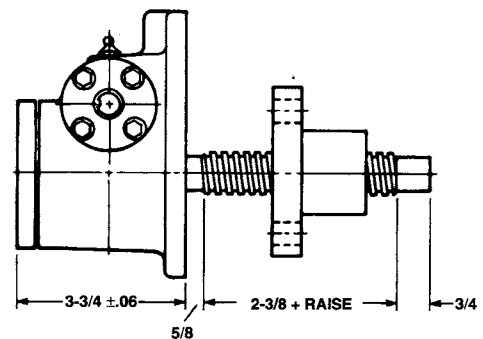

Inverted Rotating: DM-9003

Note: Lifting screw is not keyed. Top should be secured to a lifting member to prevent rotation. When a Bellows Boot is required, see pages 146-147. Dimensions are subject to change without notice.

MACHINE SCREW ACTUATORS

2 Ton Capacity, 7000 Series

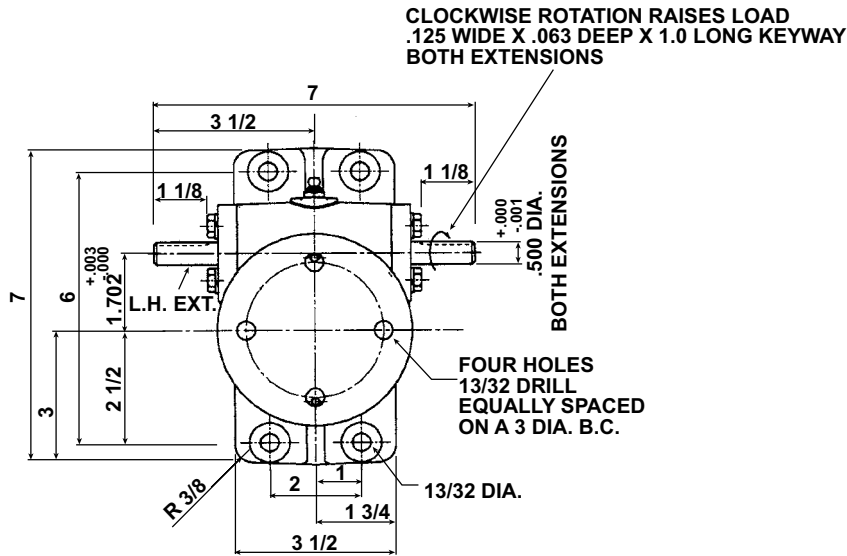

1" Diameter x .250 Lead Lifting Screw

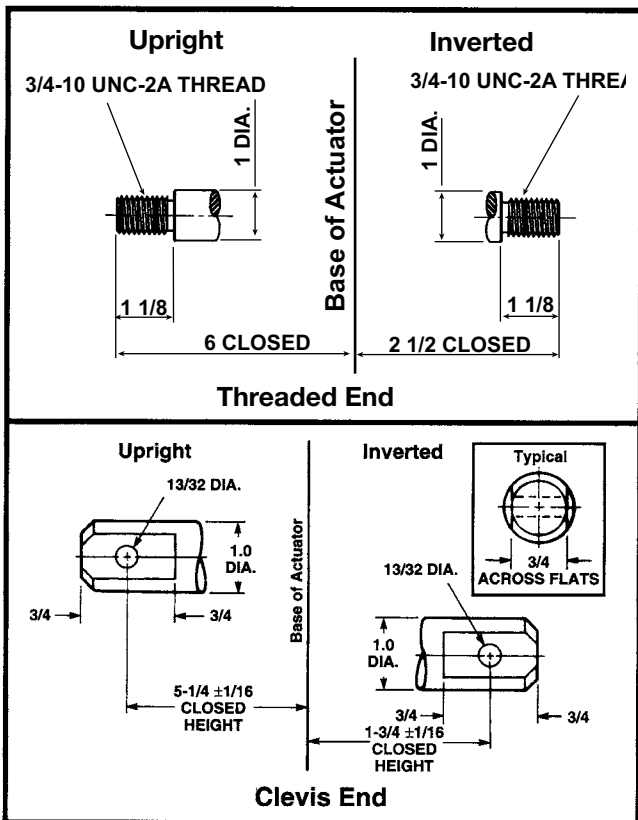

Note: Lifting screw is not keyed. Top should be secured to a lifting member to prevent rotation. When a Bellows Boot is required, see pages 146-147. Dimensions are subject to change without notice.

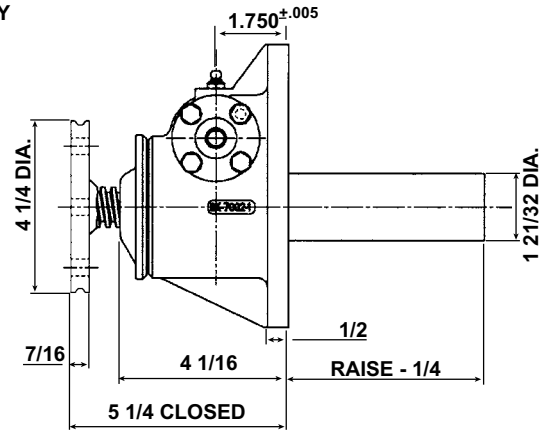

Upright: M-7002

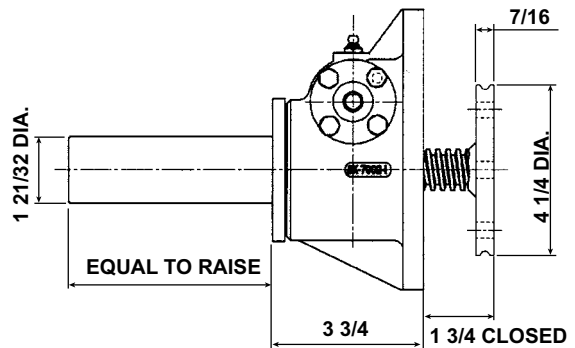

Inverted: M-7001

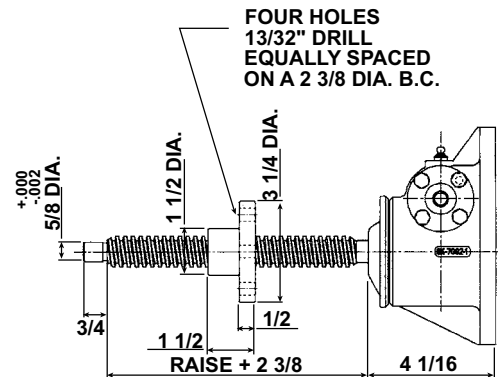

Upright Rotating: UM-7003

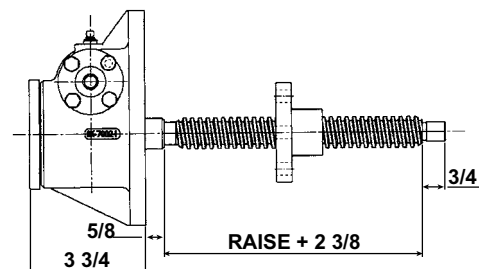

Inverted Rotating: DM-7003

2 Ton Capacity, 1800 Series

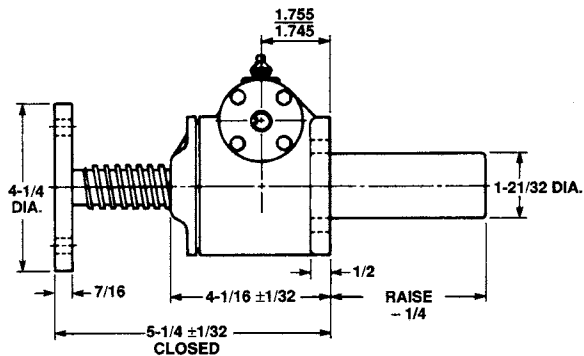
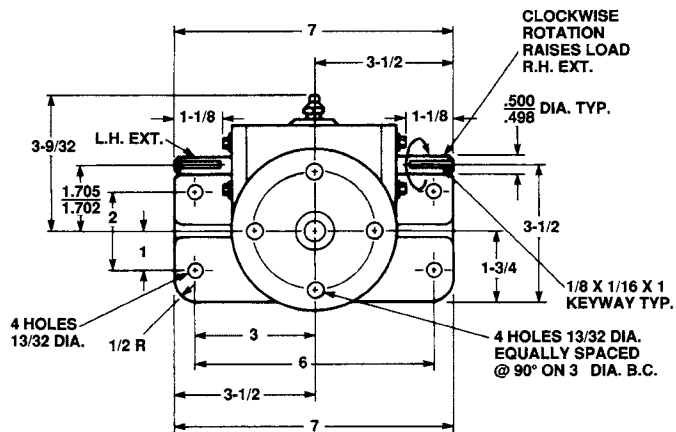

Upright: M-1802

1" Diameter x .250 Lead Lifting Screws

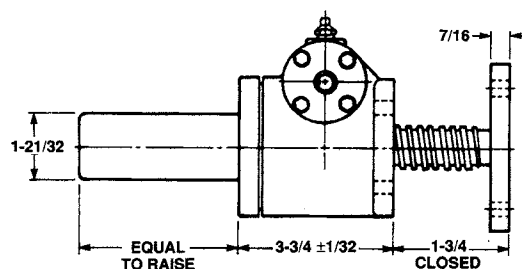
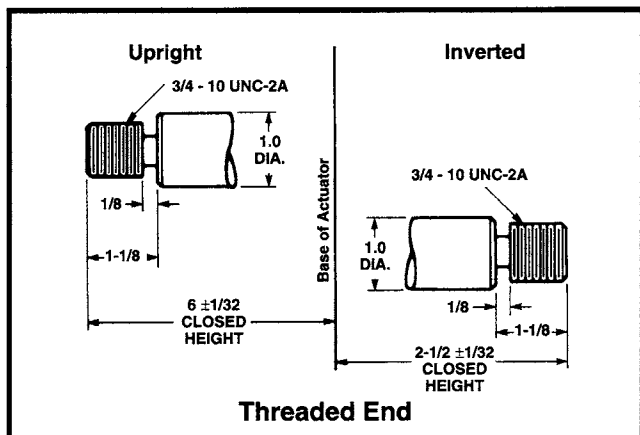

Inverted: M-1801

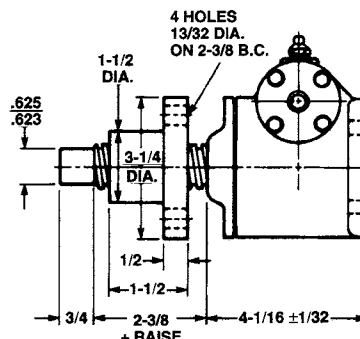
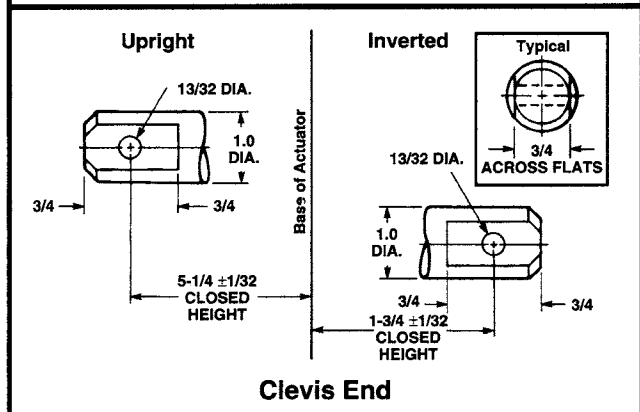

Upright Rotating: UM-1803

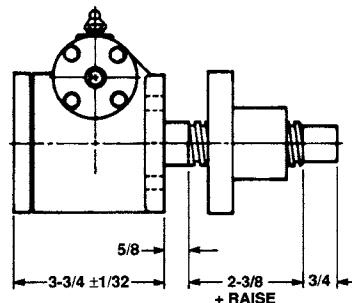
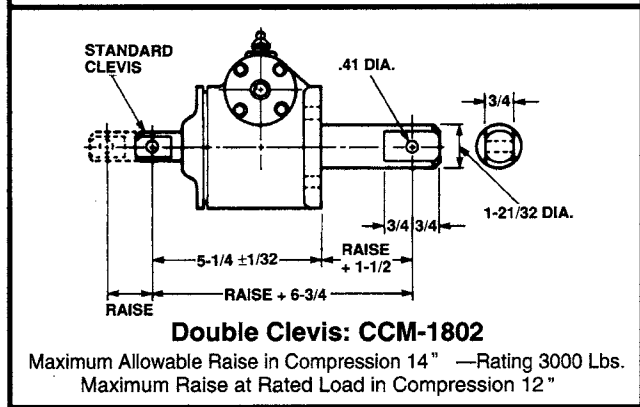

Inverted Rotating: DM-1803

Note: Lifting screw is not keyed. Top should be secured to a lifting member to prevent rotation. When a Bellows Boot is required, see pages 146-147. Dimensions are subject to change without notice.

MACHINE SCREW ACTUATORS

3 Ton Capacity

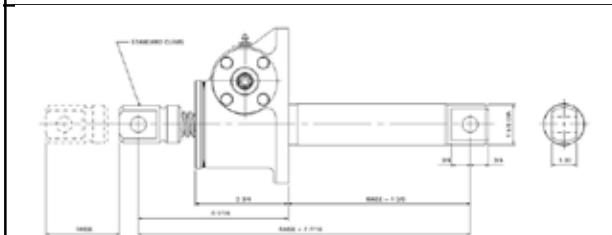
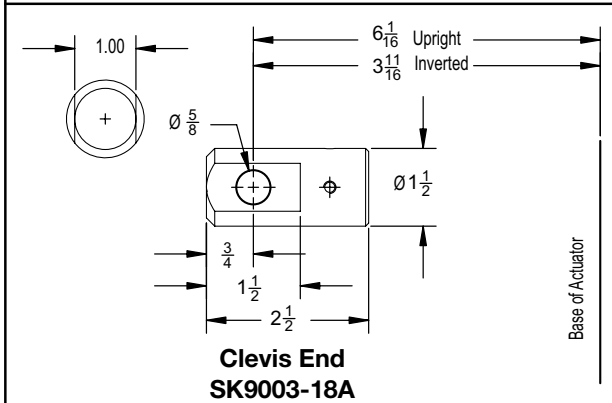
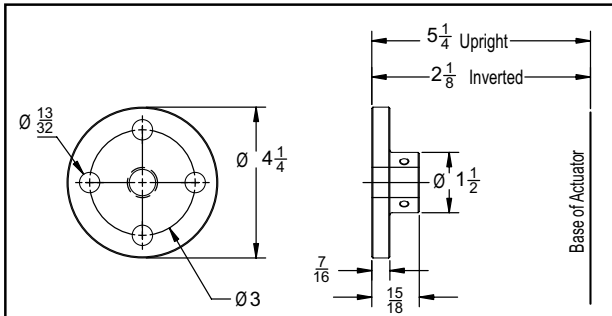
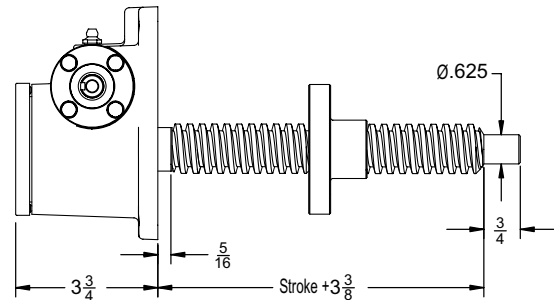
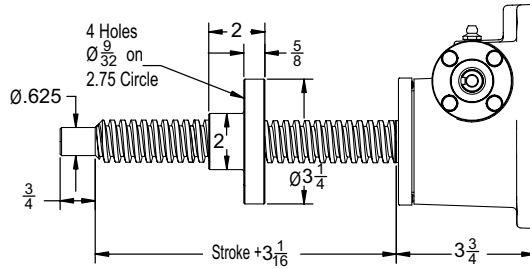
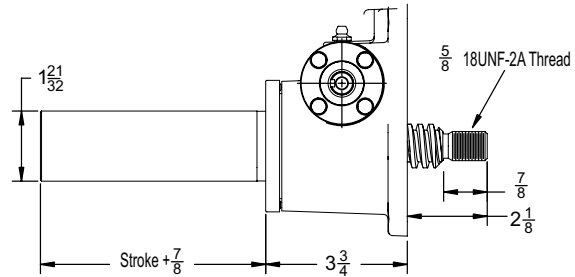
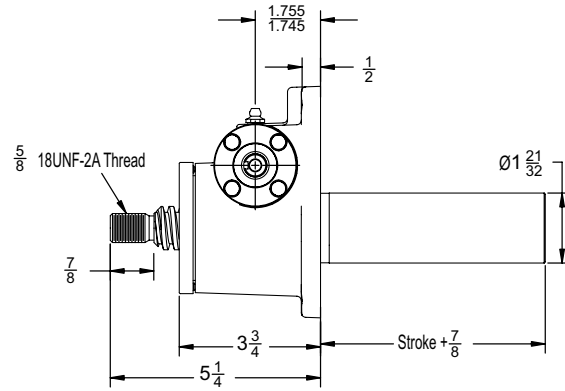
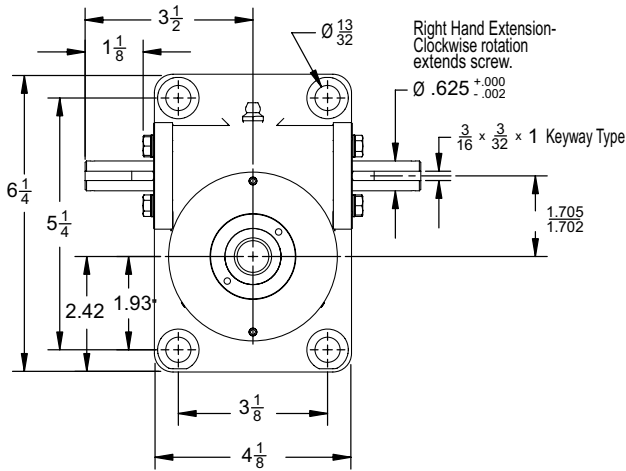

Maximum allowable raise in compression 14" - rating
3000 lbs maximum raise at rated load in compression 9"

Note: Lifting screw is not keyed. Top should be secured to a lifting member to prevent rotation. When a Bellows Boot is required, see pages 146-147. Dimensions are subject to change without notice.

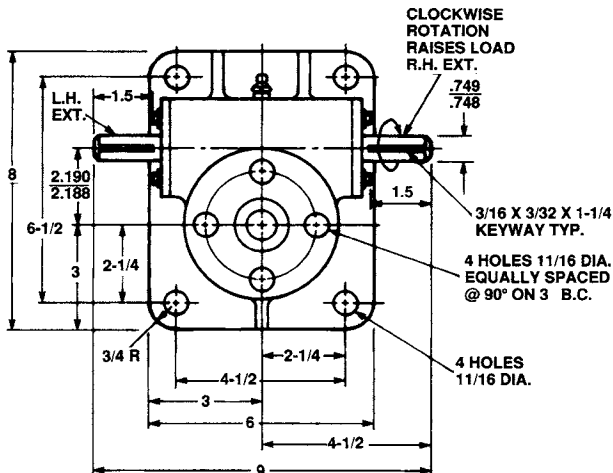

1 1/2" Diameter x .375 Lead Lifting Screws

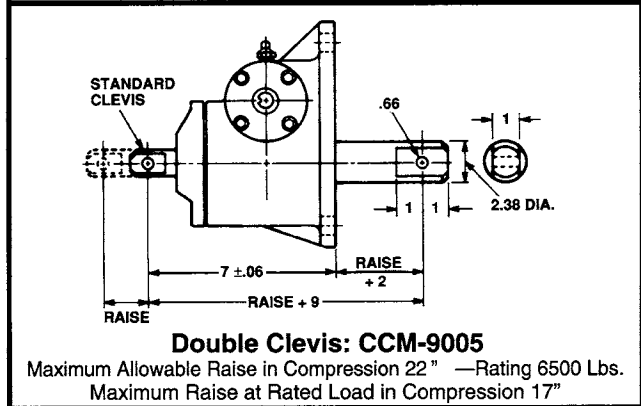
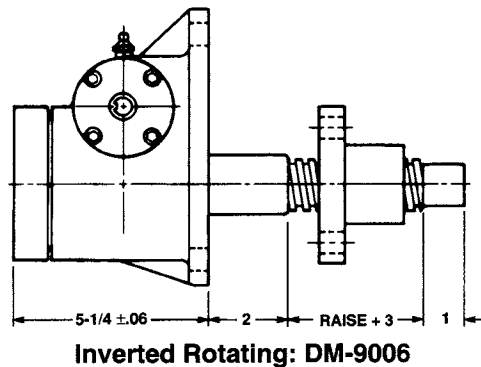
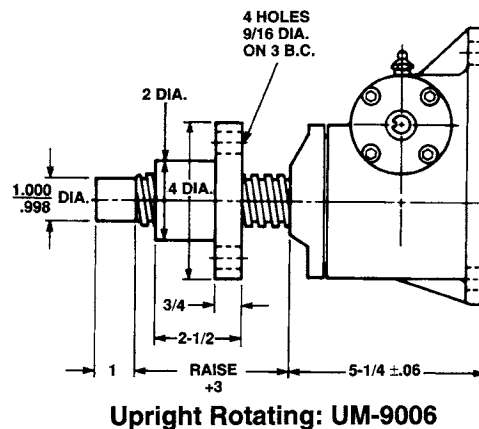
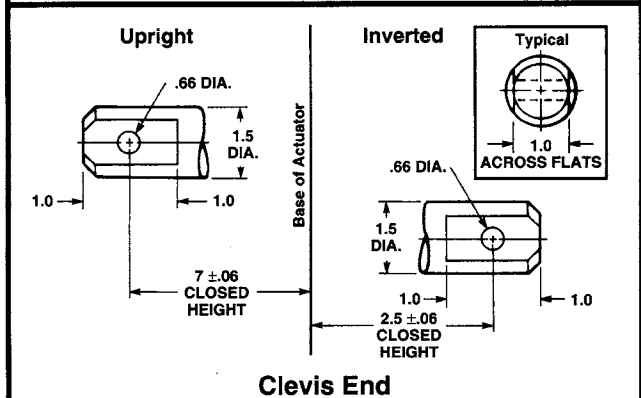
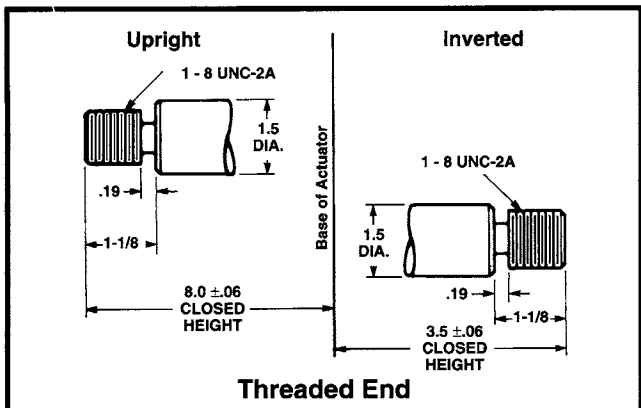
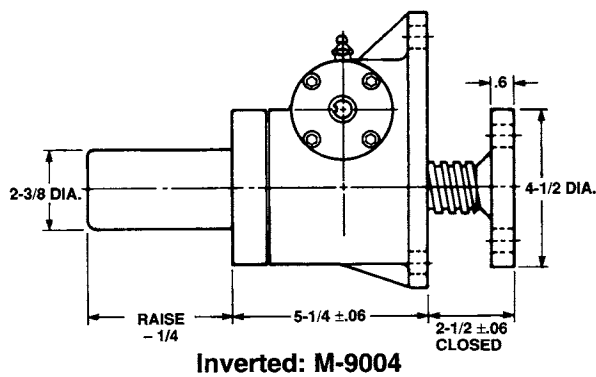
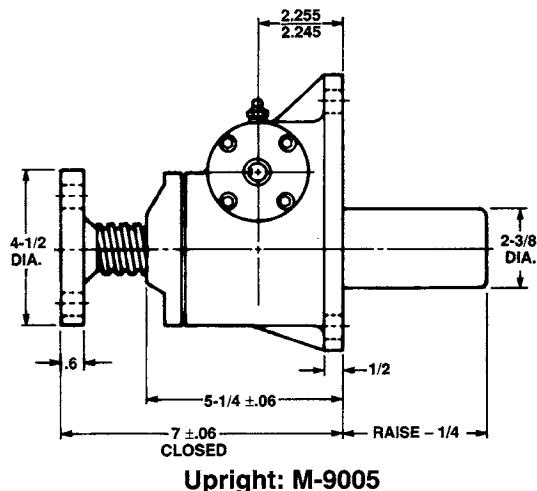

Note: Lifting screw is not keyed. Top should be secured to a lifting member to prevent rotation. When a Bellows Boot is required, see pages 146-147. Dimensions are subject to change without notice.

MACHINE SCREW ACTUATORS

10 Ton Capacity

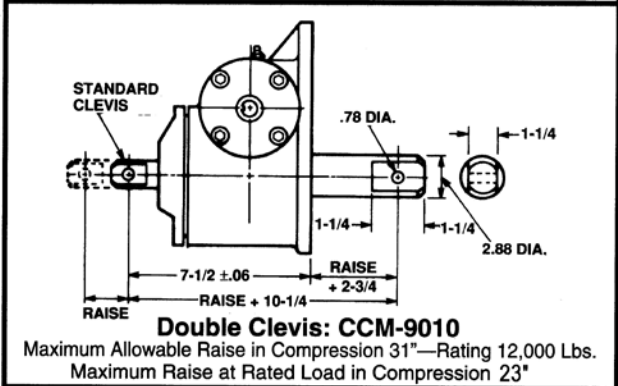
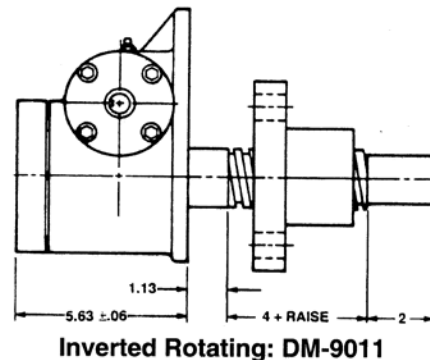
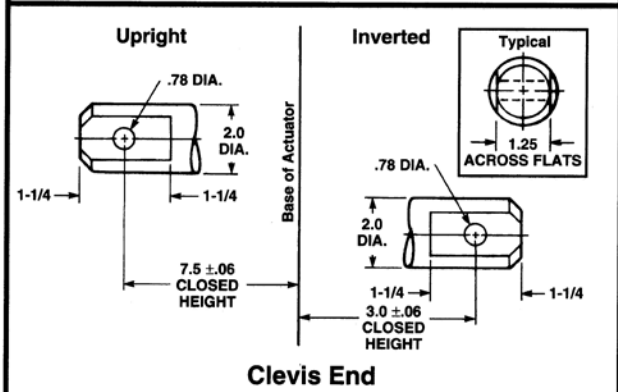
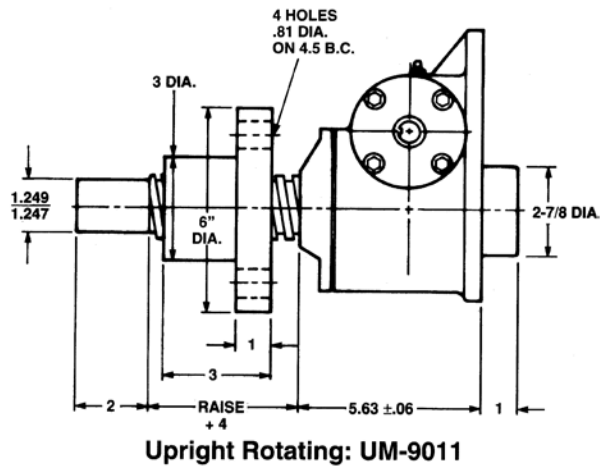
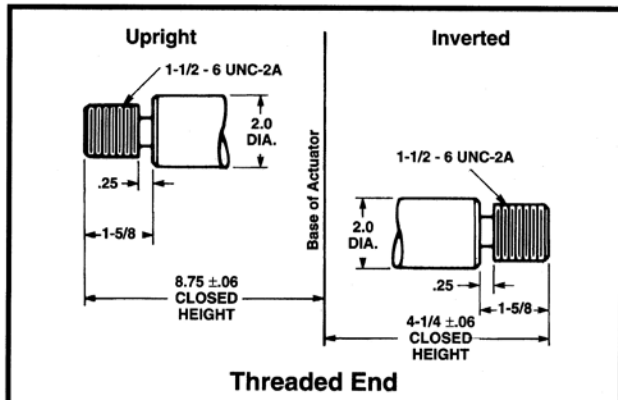
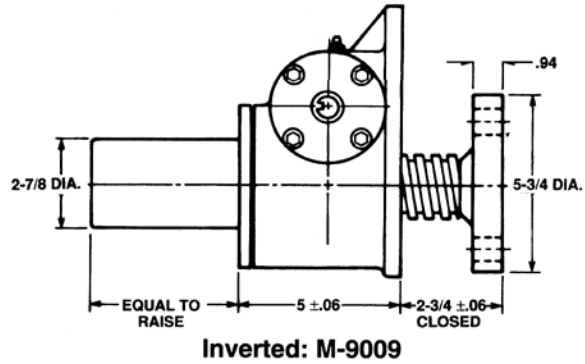
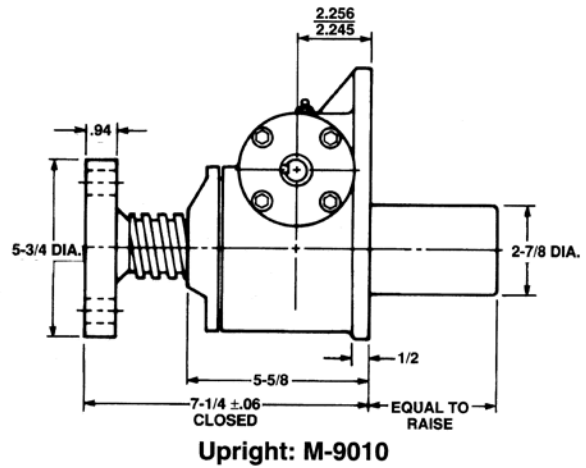
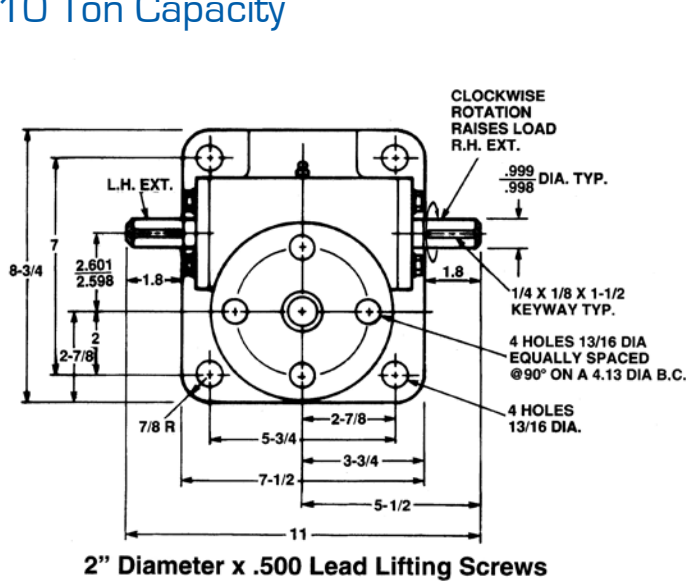

Note: Lifting screw is not keyed. Top should be secured to a lifting member to prevent rotation. When a Bellows Boot is required, see pages 146-147. Dimensions are subject to change without notice.

15 Ton Capacity

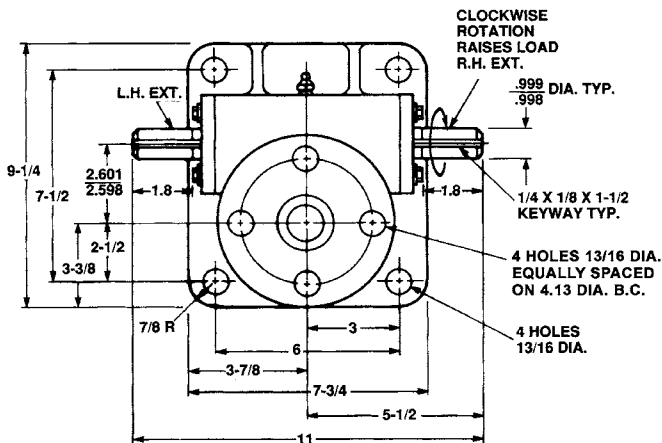

2 1/4" Diameter x .500 Lead Lifting Screws

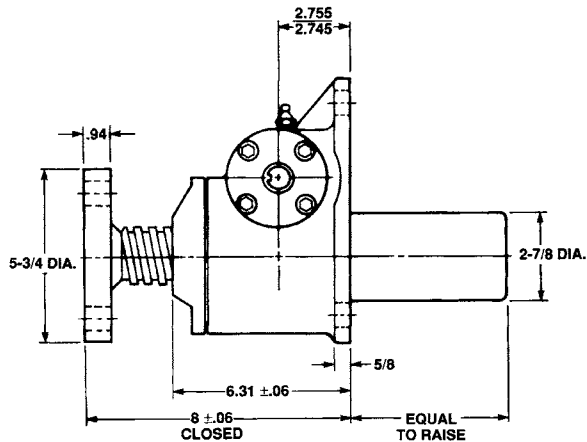

Upright: M-9015

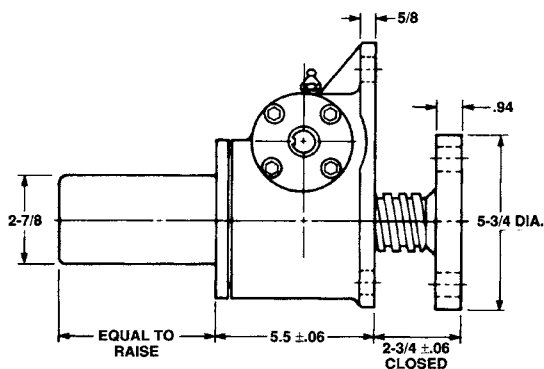

Inverted: M-9014

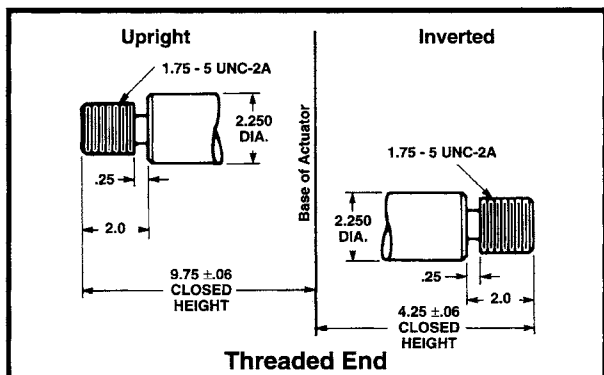

Threaded End

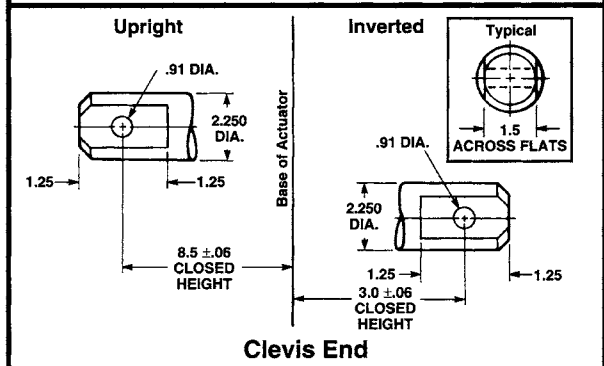

Clevis End

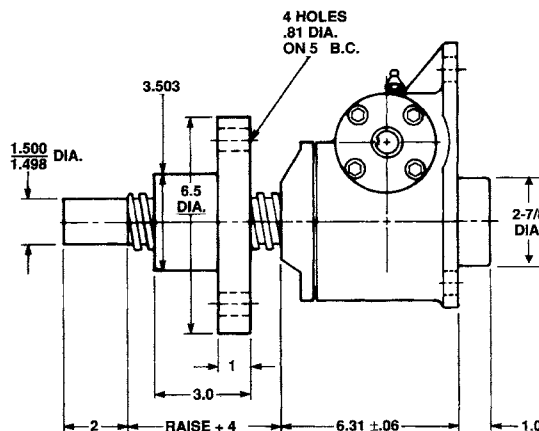

Upright Rotating: UM-9016

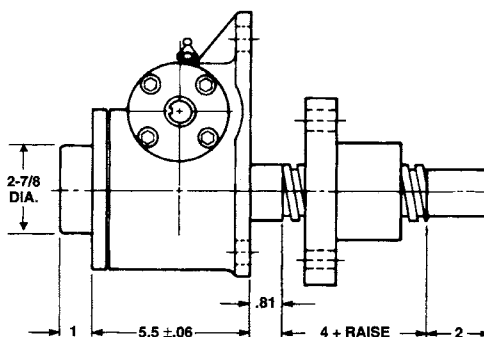

Inverted Rotating: DM-9016

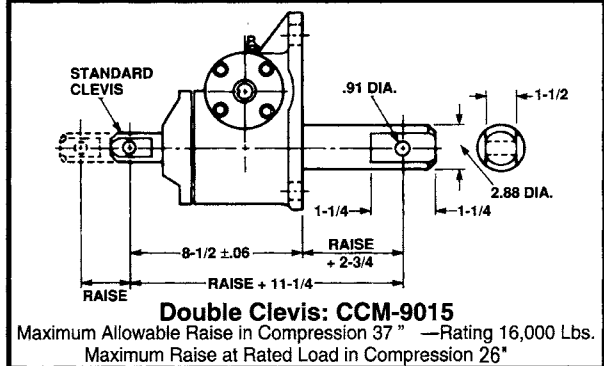

Double Clevis: CCM-9015

Maximum Allowable Raise in Compression 37" — Rating 16,000 Lbs.
Maximum Raise at Rated Load in Compression 26"

Note: Lifting screw is not keyed. Top should be secured to a lifting member to prevent rotation. When a Bellows Boot is required, see pages 146-147. Dimensions are subject to change without notice.

MACHINE SCREW ACTUATORS

20 Ton Capacity

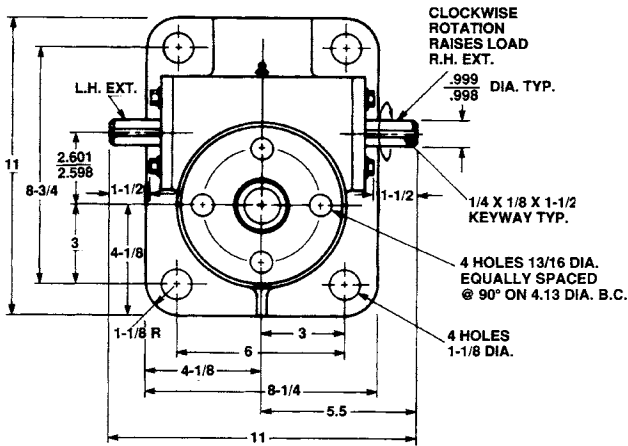

2 1/2" Diameter x .500 Lead Lifting Screws

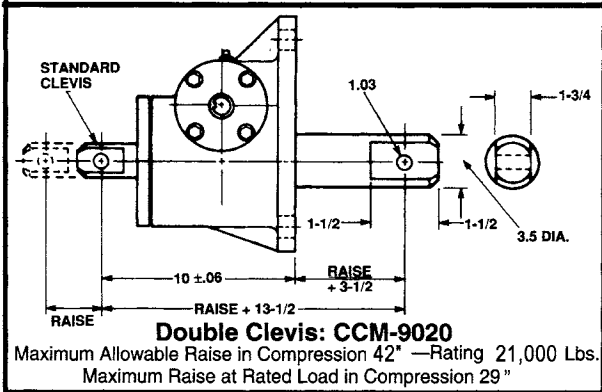
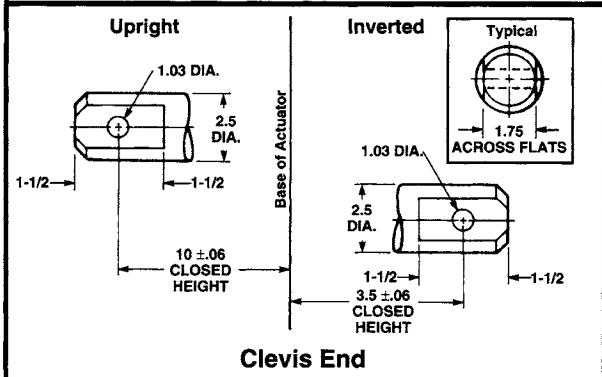
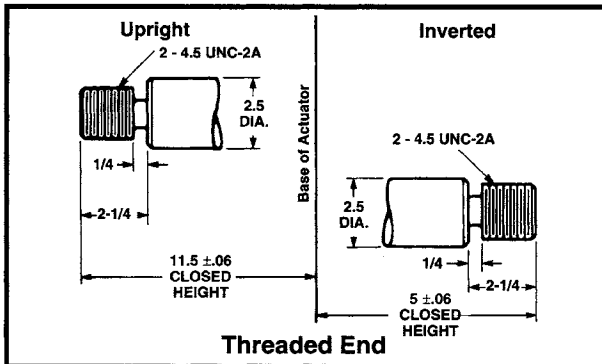

Note: Lifting screw is not keyed. Top should be secured to a lifting member to prevent rotation. When a Bellows Boot is required, see pages 146-147. Dimensions are subject to change without notice.

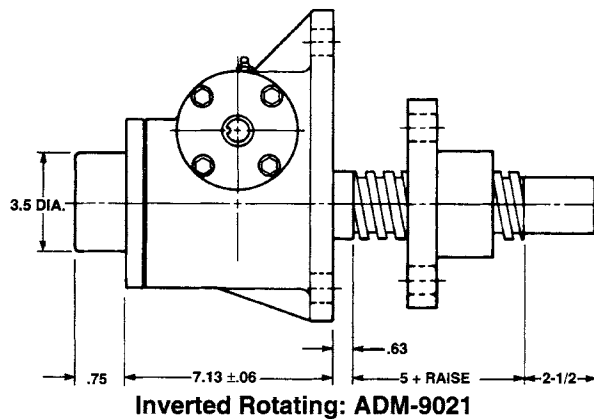
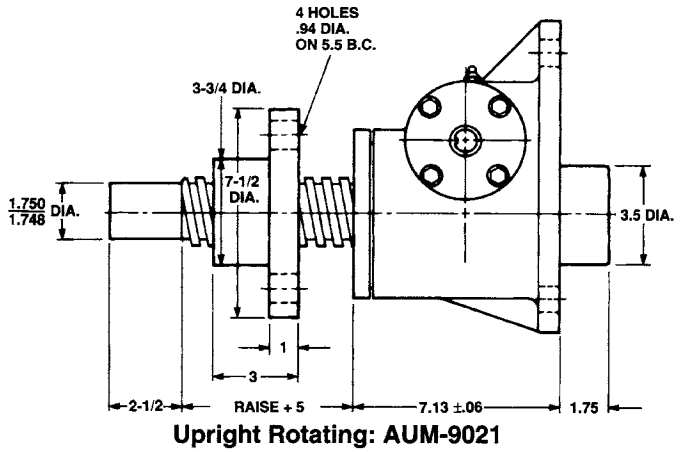
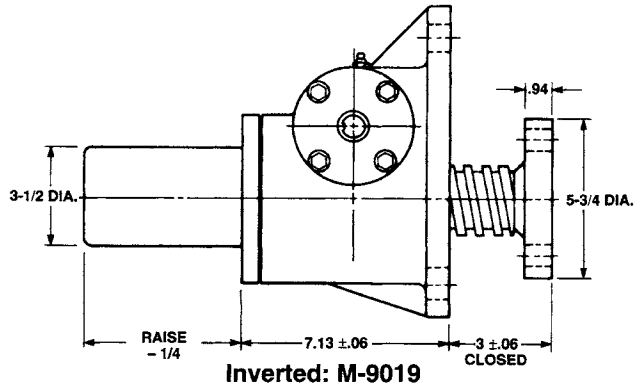
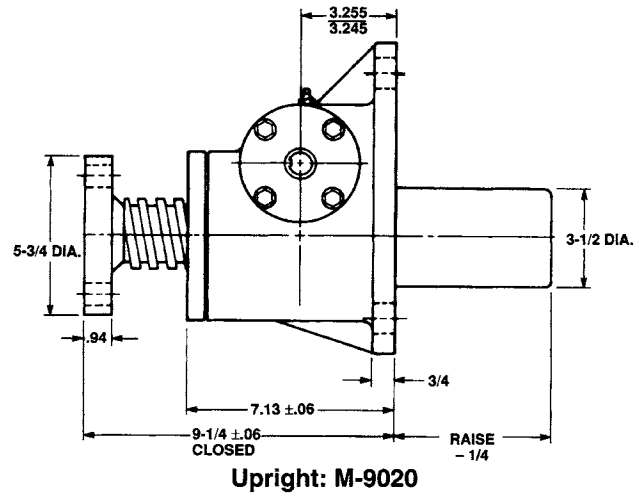

25 Ton Capacity

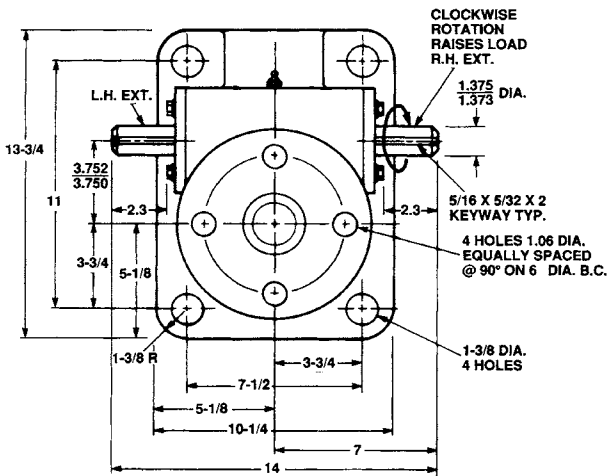

3" Diameter x .666 Lead Lifting Screws

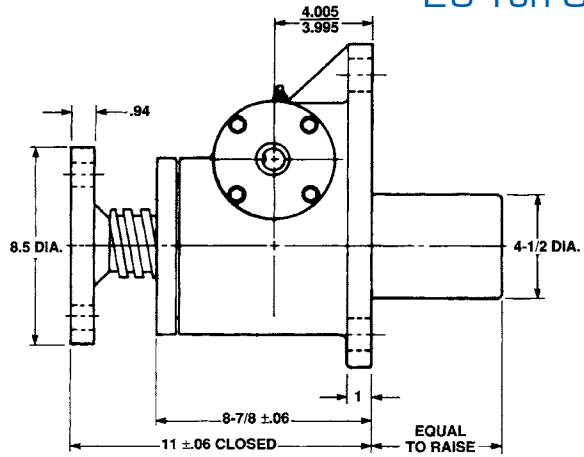

Upright: M-9025

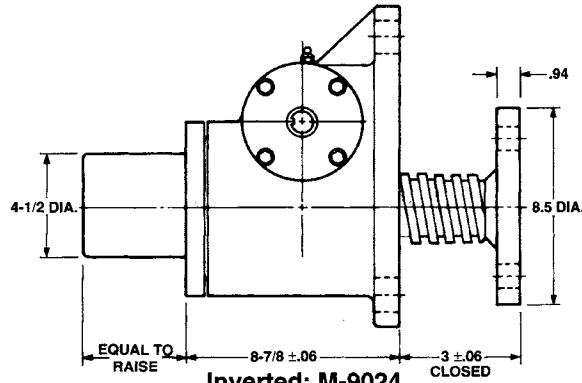

Inverted: M-9024

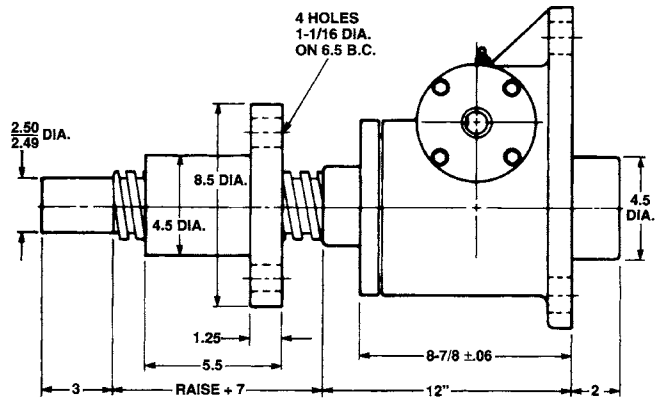

Upright Rotating: UM-9026

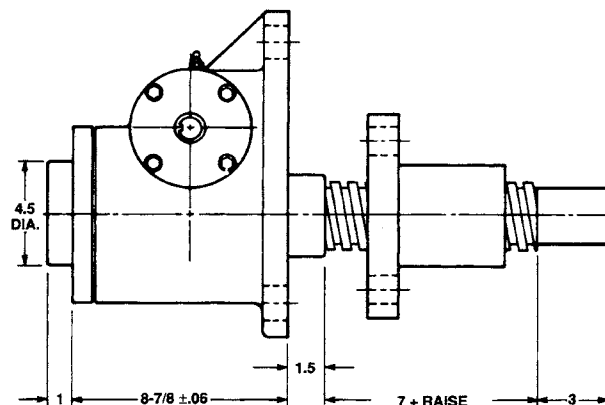

Inverted Rotating: DM-9026

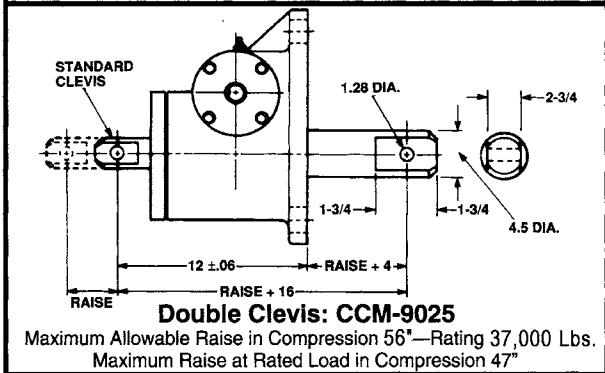
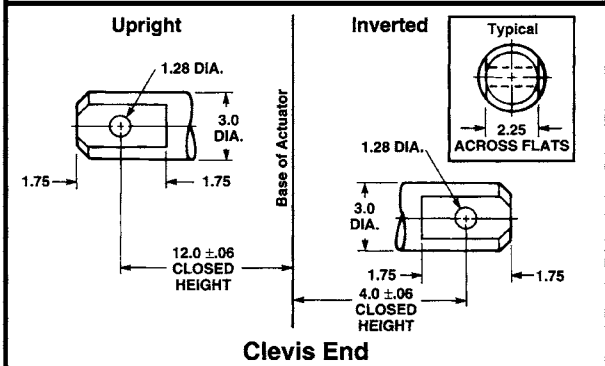
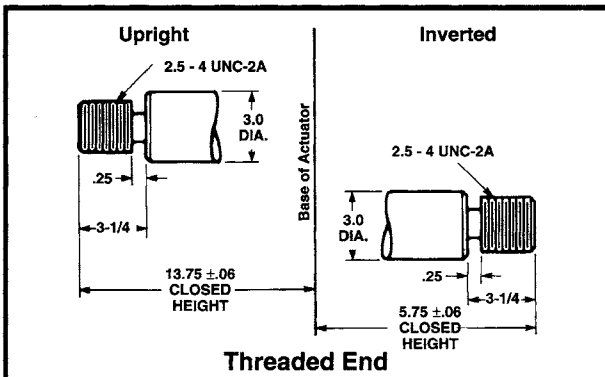

Note: Lifting screw is not keyed. Top should be secured to a lifting member to prevent rotation. When a Bellows Boot is required, see pages 146-147. Dimensions are subject to change without notice.

MACHINE SCREW ACTUATORS

35 Ton Capacity

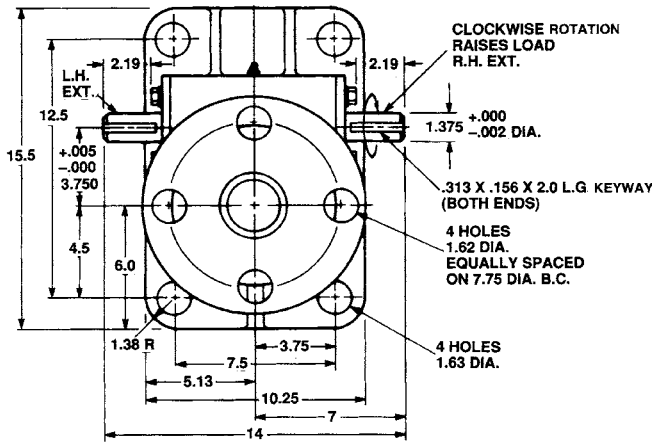

3 $\frac{3}{4}$ " Diameter x .666 Lead Lifting Screws

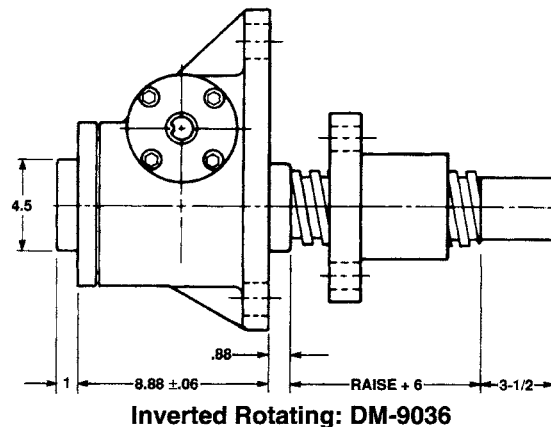
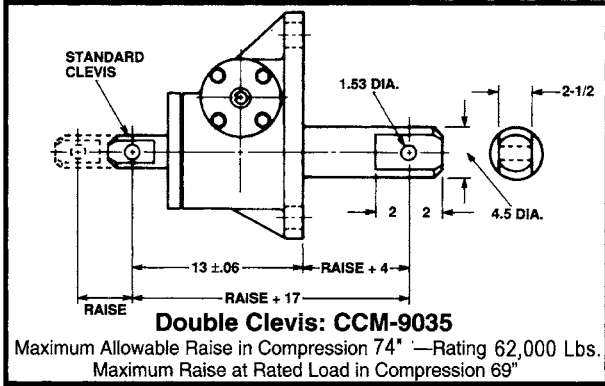
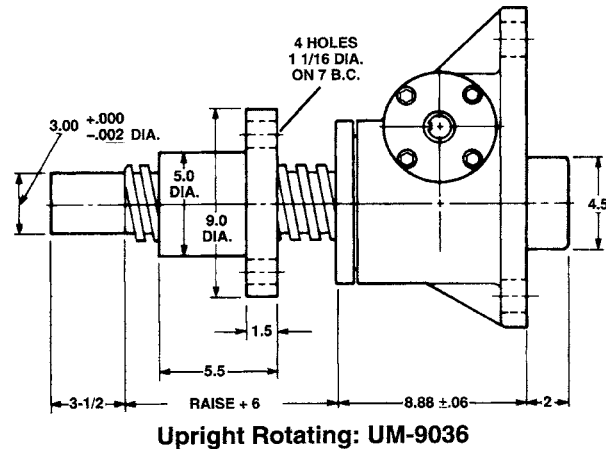
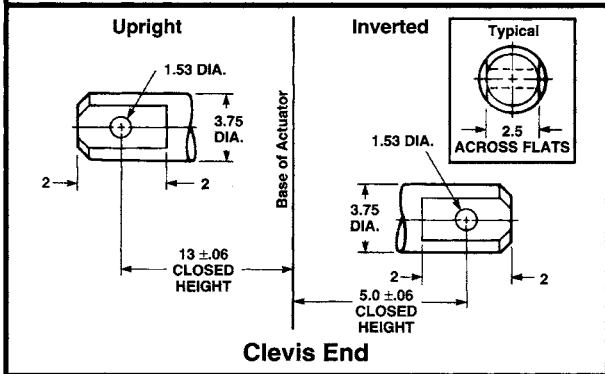
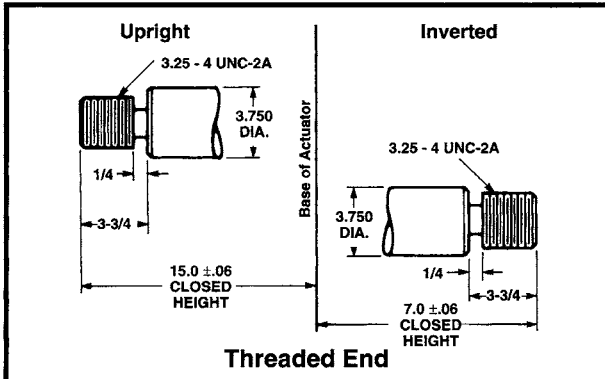
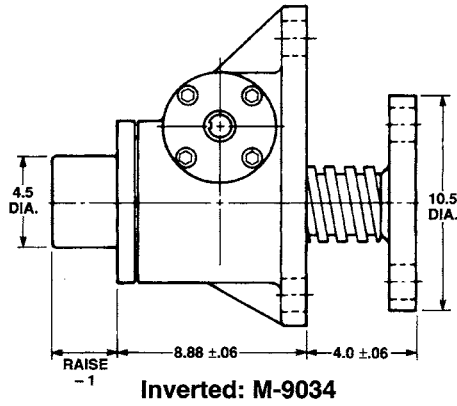
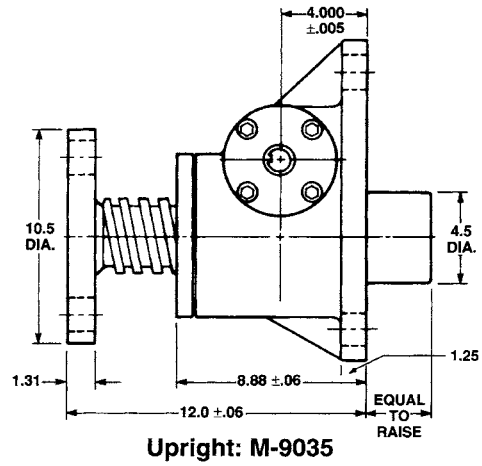

Note: Lifting screw is not keyed. Top should be secured to a lifting member to prevent rotation. When a Bellows Boot is required, see pages 146-147. Dimensions are subject to change without notice.

50 Ton Capacity, 9000 Series

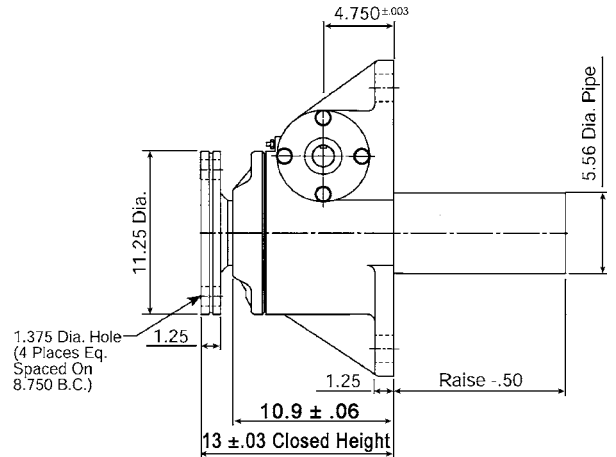
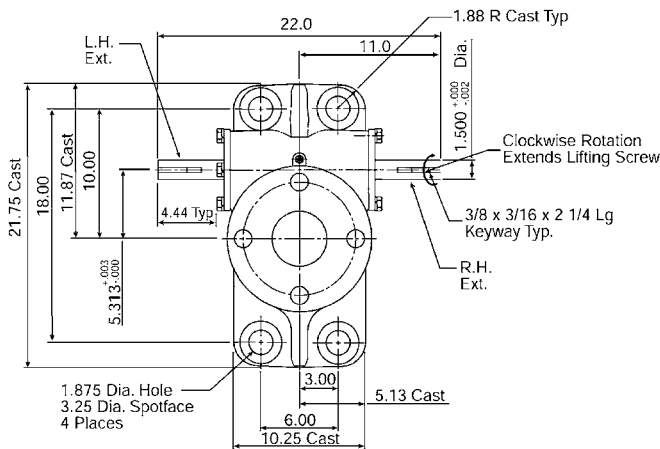

Upright: M-9050

4 1/2" Diameter x .666 Lead Lifting Screw

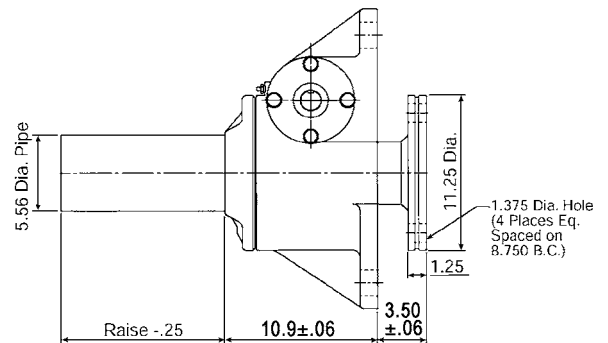
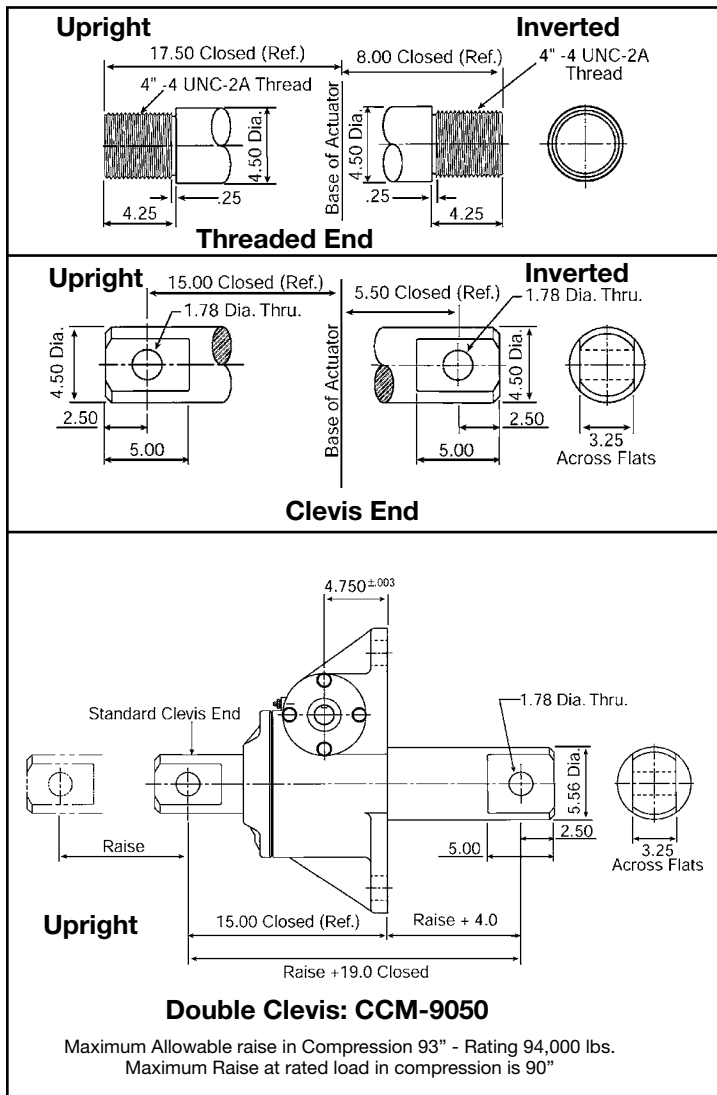

Inverted: M-9049

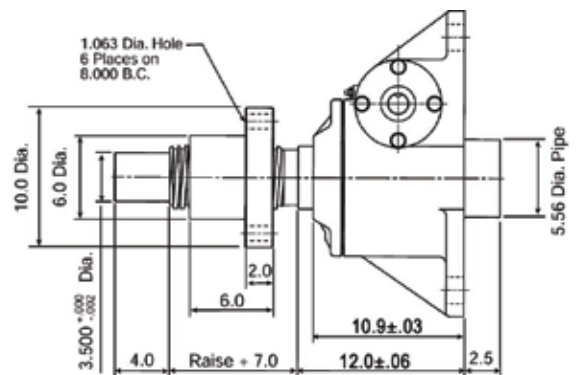

Upright Rotating: UM-9051

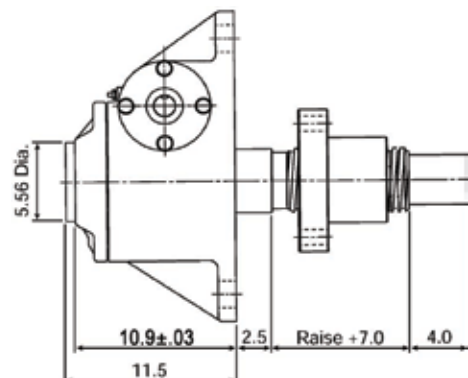

Inverted Rotating: DM-9051

Note: Lifting screw is not keyed. Top should be secured to a lifting member to prevent rotation. When a Bellows Boot is required, see pages 146-147. Dimensions are subject to change without notice.

MACHINE SCREW ACTUATORS

50 Ton Capacity, 1800 Series

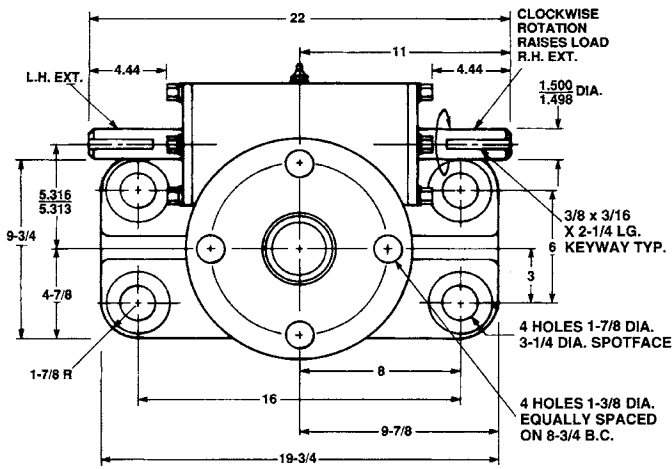

4 1/2" Diameter x .666 Lead Lifting Screws

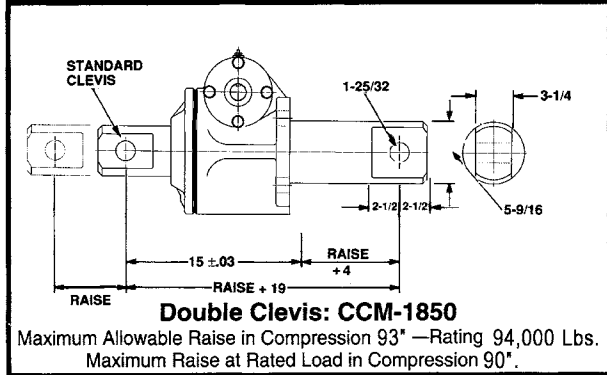
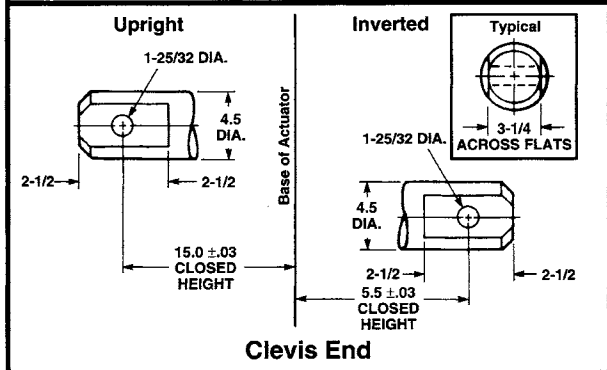
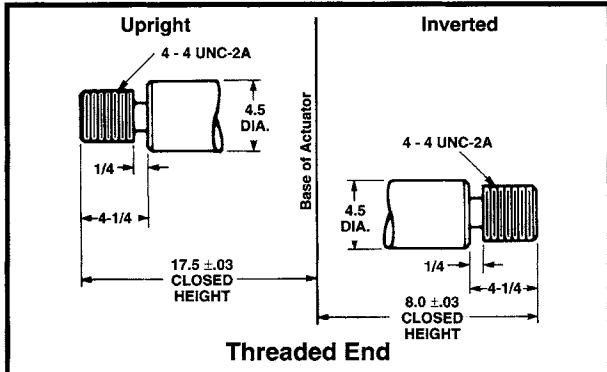

Note: Lifting screw is not keyed. Top should be secured to a lifting member to prevent rotation. When a Bellows Boot is required, see pages 146-147. Dimensions are subject to change without notice.

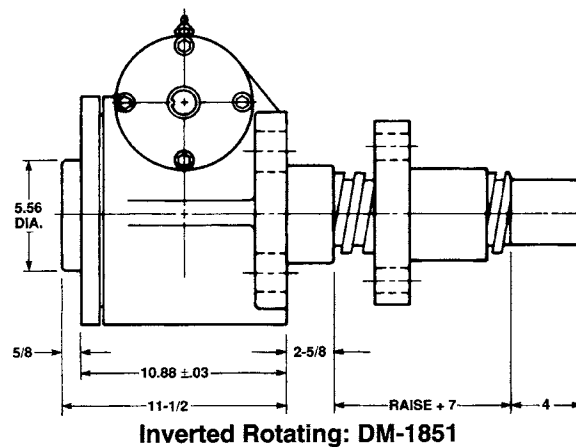
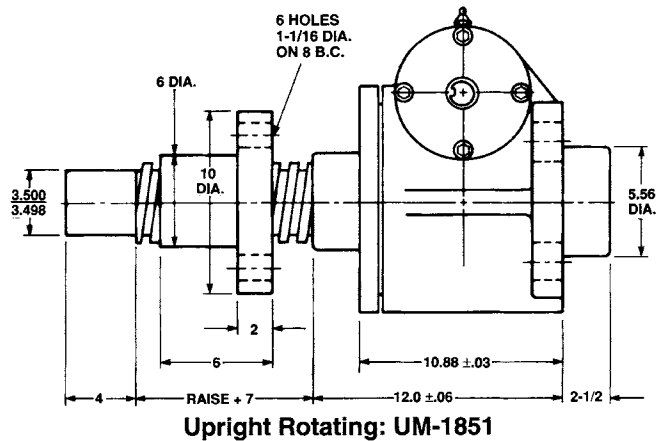
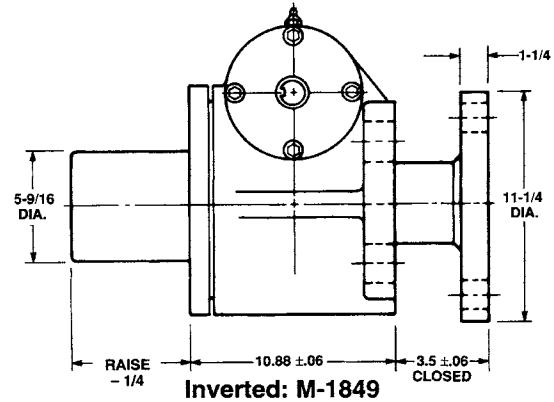
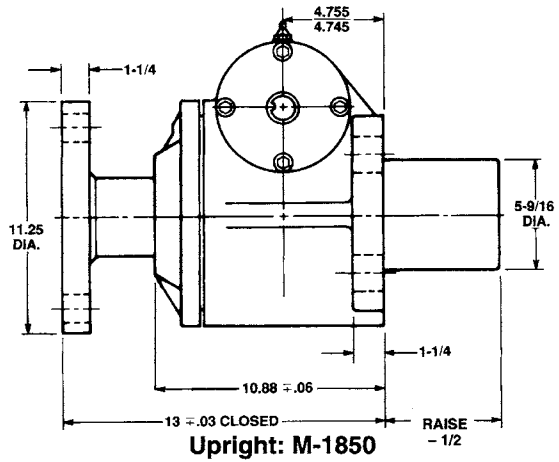

75 Ton Capacity

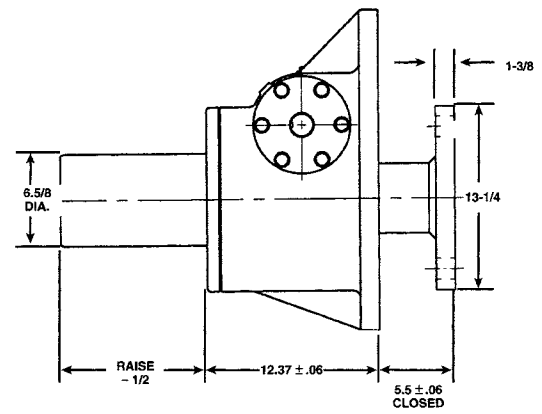
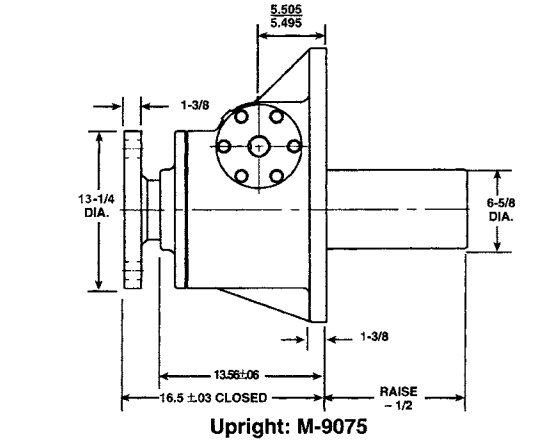
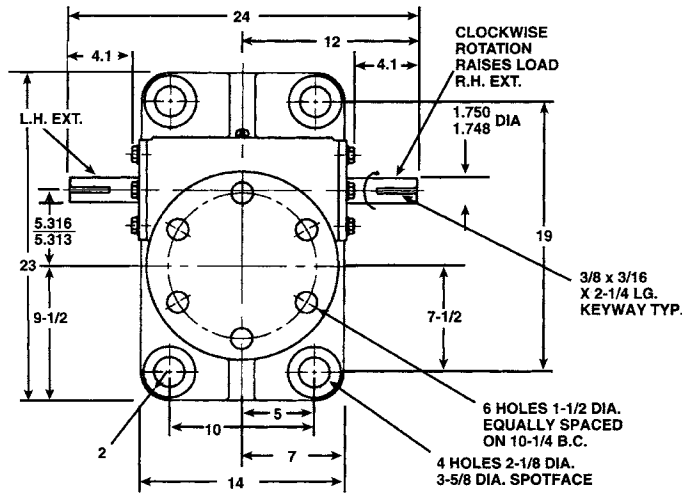

5" Diameter x .666 Lead Lifting Screws

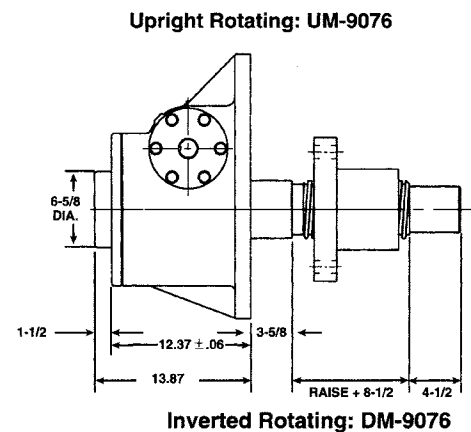
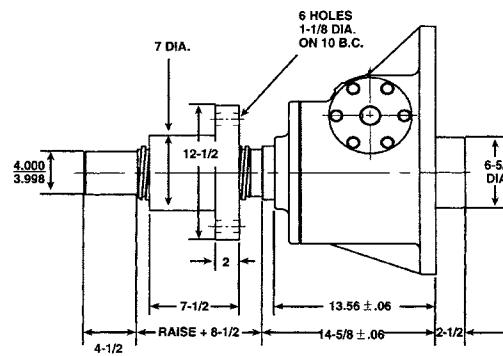
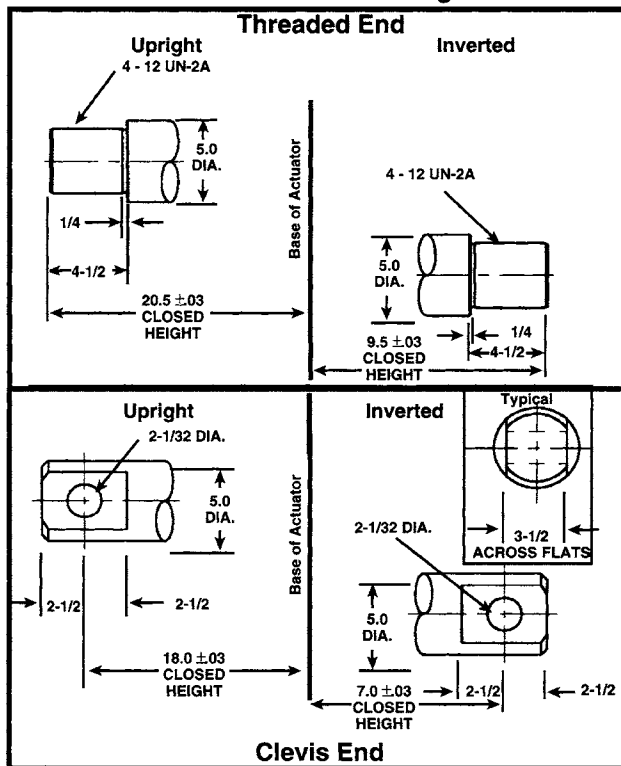

Note: Lifting screw is not keyed. Top should be secured to a lifting member to prevent rotation. When a Bellows Boot is required, see pages 146-147. Dimensions are subject to change without notice.

MACHINE SCREW ACTUATORS

100 Ton Capacity

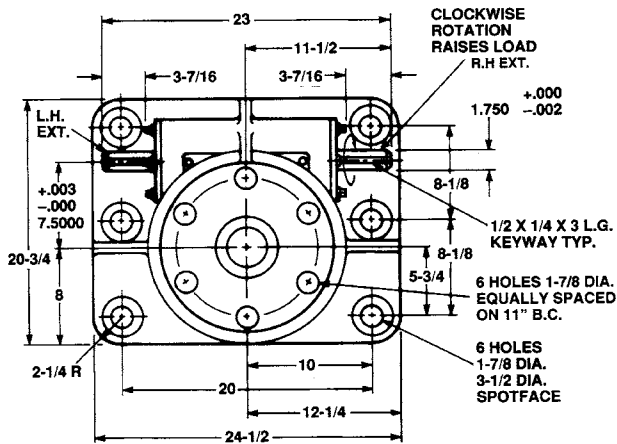

6" Diameter x .750 Lead Lifting Screws

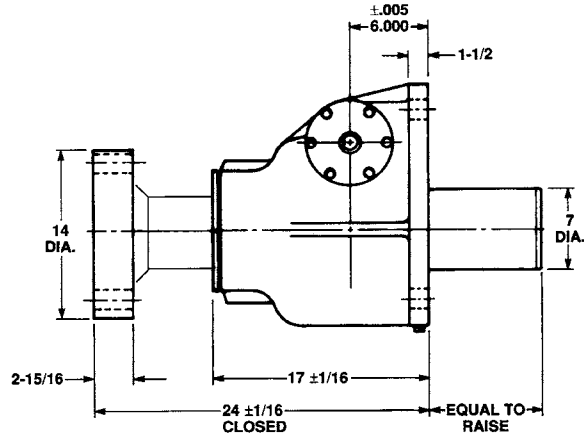

Upright: M-9099

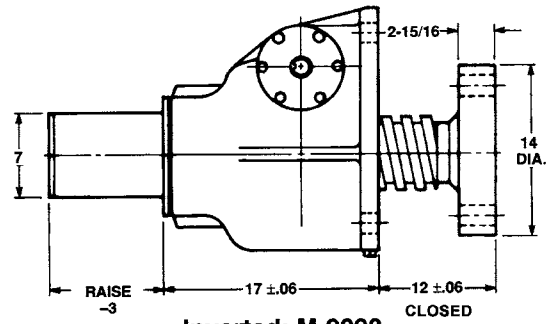

Inverted: M-9098

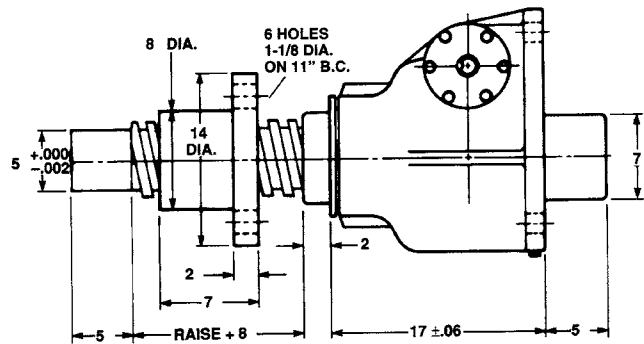

Upright Rotating: UM-9097

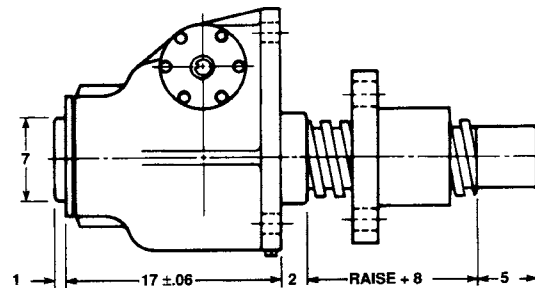

Inverted Rotating: DM-9097

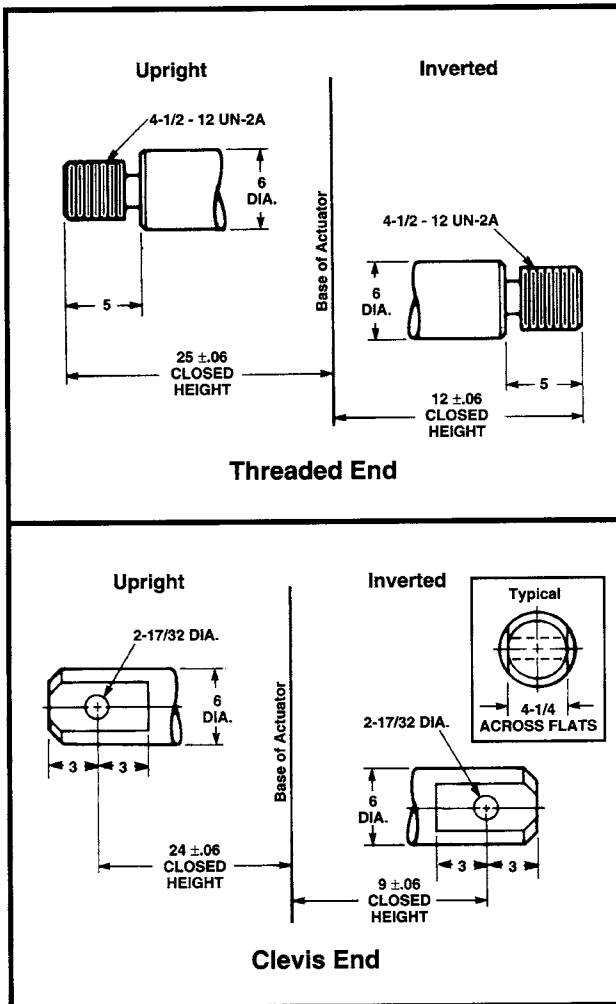

Note: Lifting screw is not keyed. Top should be secured to a lifting member to prevent rotation. When a Bellows Boot is required, see pages 146-147. Dimensions are subject to change without notice.

150 Ton Capacity

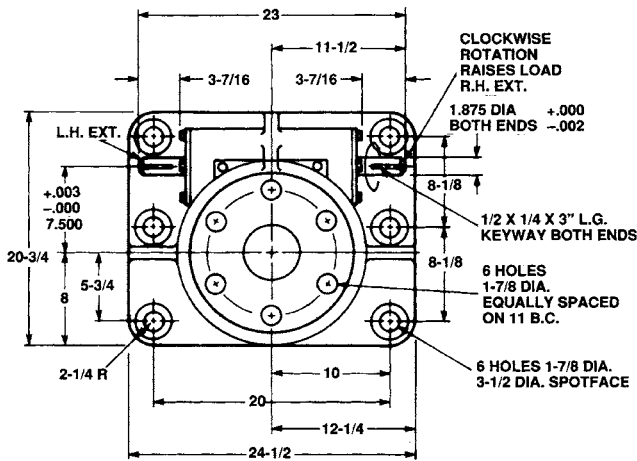

7" Diameter x 1" Lead Lifting Screws

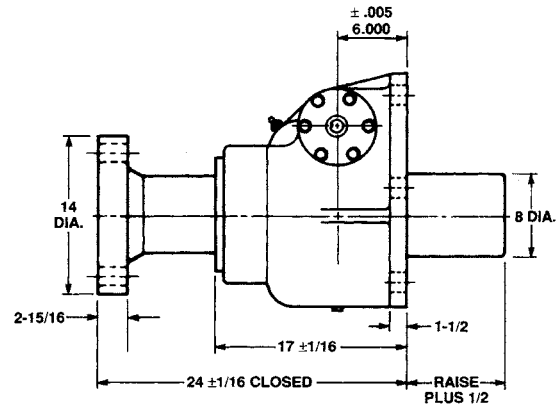

Upright: M-18150

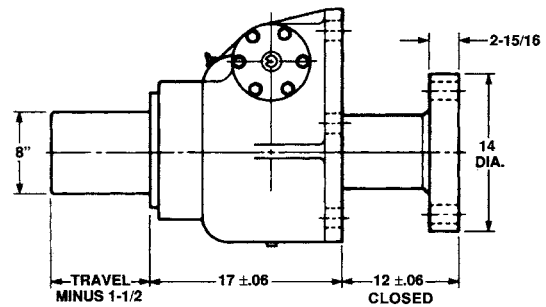

Inverted: M-18149

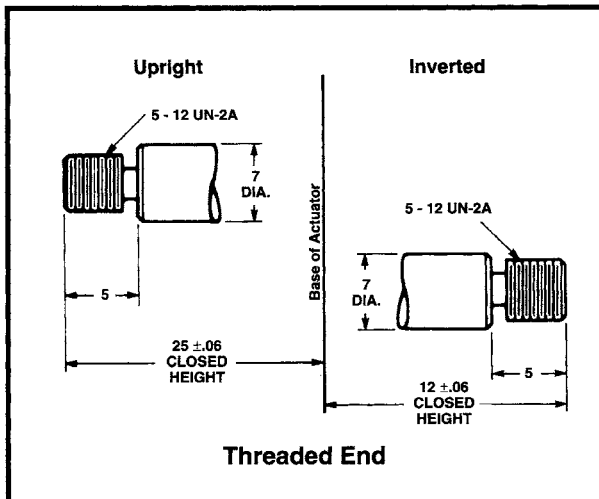

Threaded End

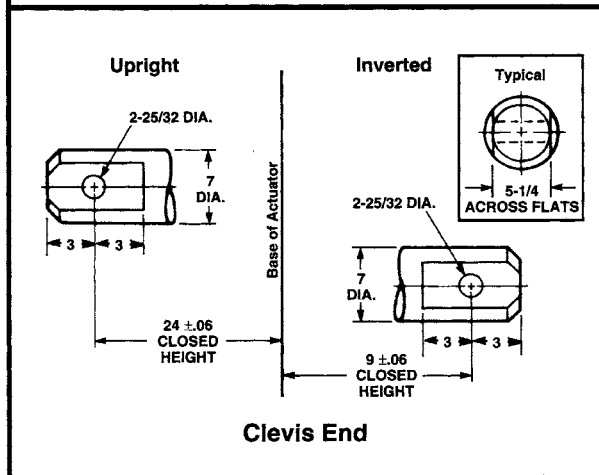

Clevis End

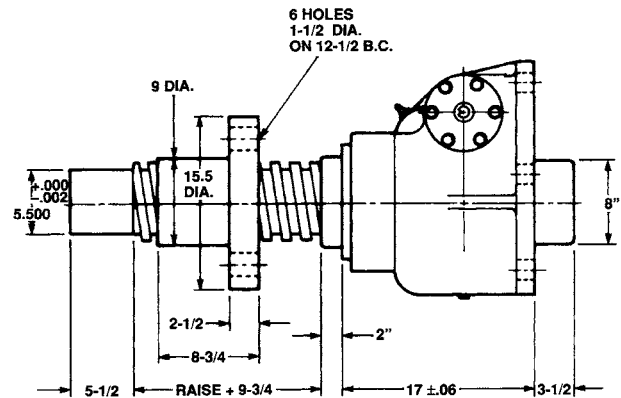

Upright Rotating: UM-18151

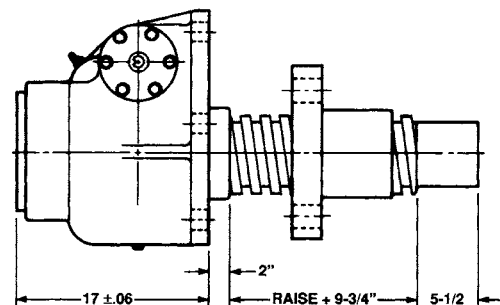

Inverted Rotating: DM-18151

Note: Lifting screw is not keyed. Top should be secured to a lifting member to prevent rotation. When a Bellows Boot is required, see pages 146-147. Dimensions are subject to change without notice.

MACHINE SCREW ACTUATORS

250 Ton Capacity

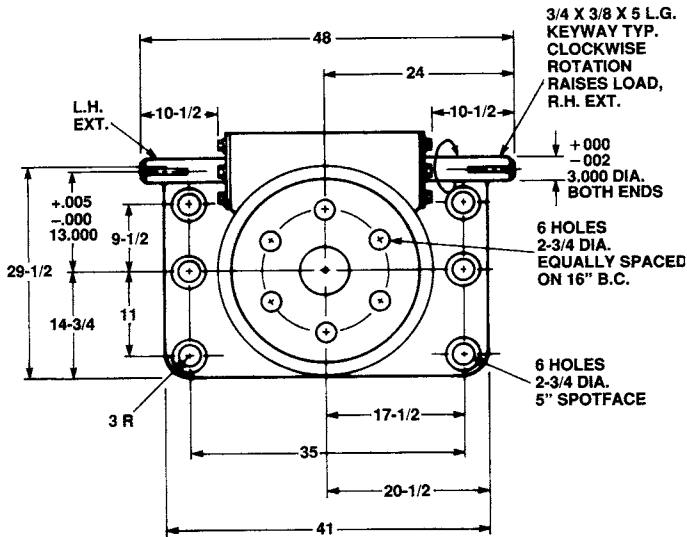

9" Diameter x 1" Lead Lifting Screws

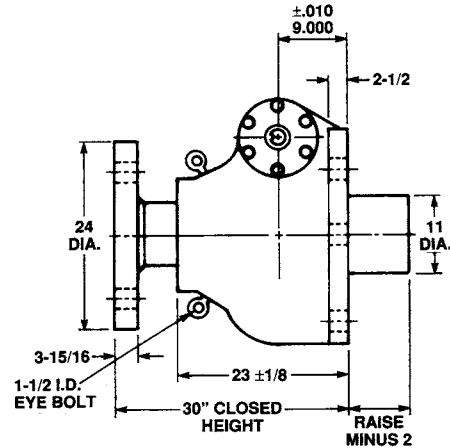

Upright: M-2250

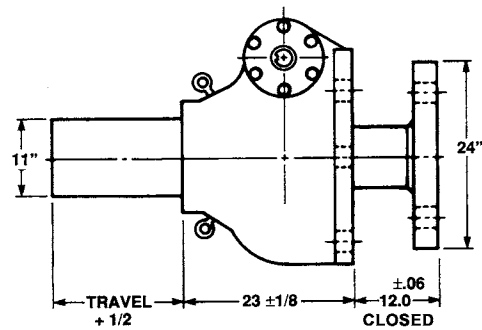

Inverted: M-2249

Note: Lifting screw is not keyed. Top should be secured to a lifting member to prevent rotation. When a Bellows Boot is required, see pages 146-147. Dimensions are subject to change without notice.

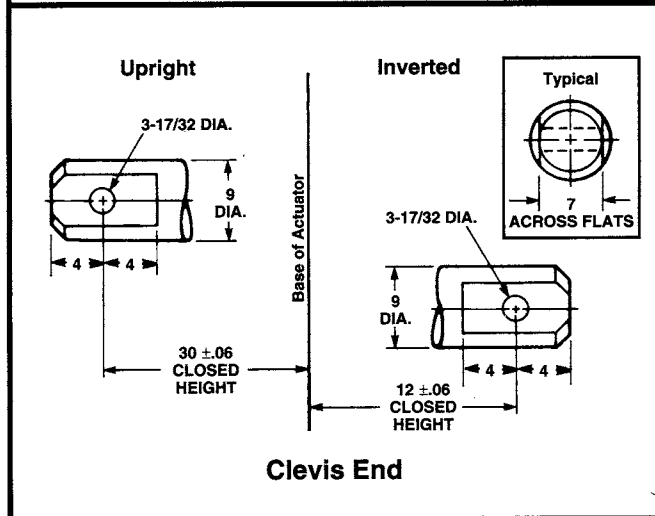
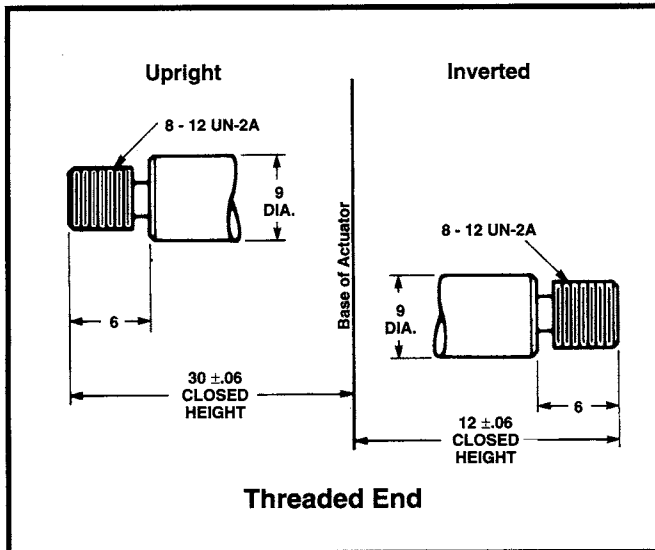

MACHINE SCREW STAINLESS STEEL

ACTUATORS

2 to 100 Tons

Top Plate 316 S.S.
Must be bolted to lifting member to prevent rotation except when screw is keyed.

Lifting Screw 316 S.S.
Also available as threaded end or clevis end.

Shell Cap 316 S.S.
Locked into place by set screws.

Carbon Steel Load Bearings
Top and bottom to take full load in either direction.

Worm Bearings & Seals
Both ends of worm. 316 S.S. case and spring.

Worm Gear
Wear resistant Bronze. Accurately hobbled for greater gear contact.

Worm
316 S.S. Standard.
(17-4 Ph available)

Housing
316 S.S.

Coverpipe 316 S.S.
Protects lifting screw threads.

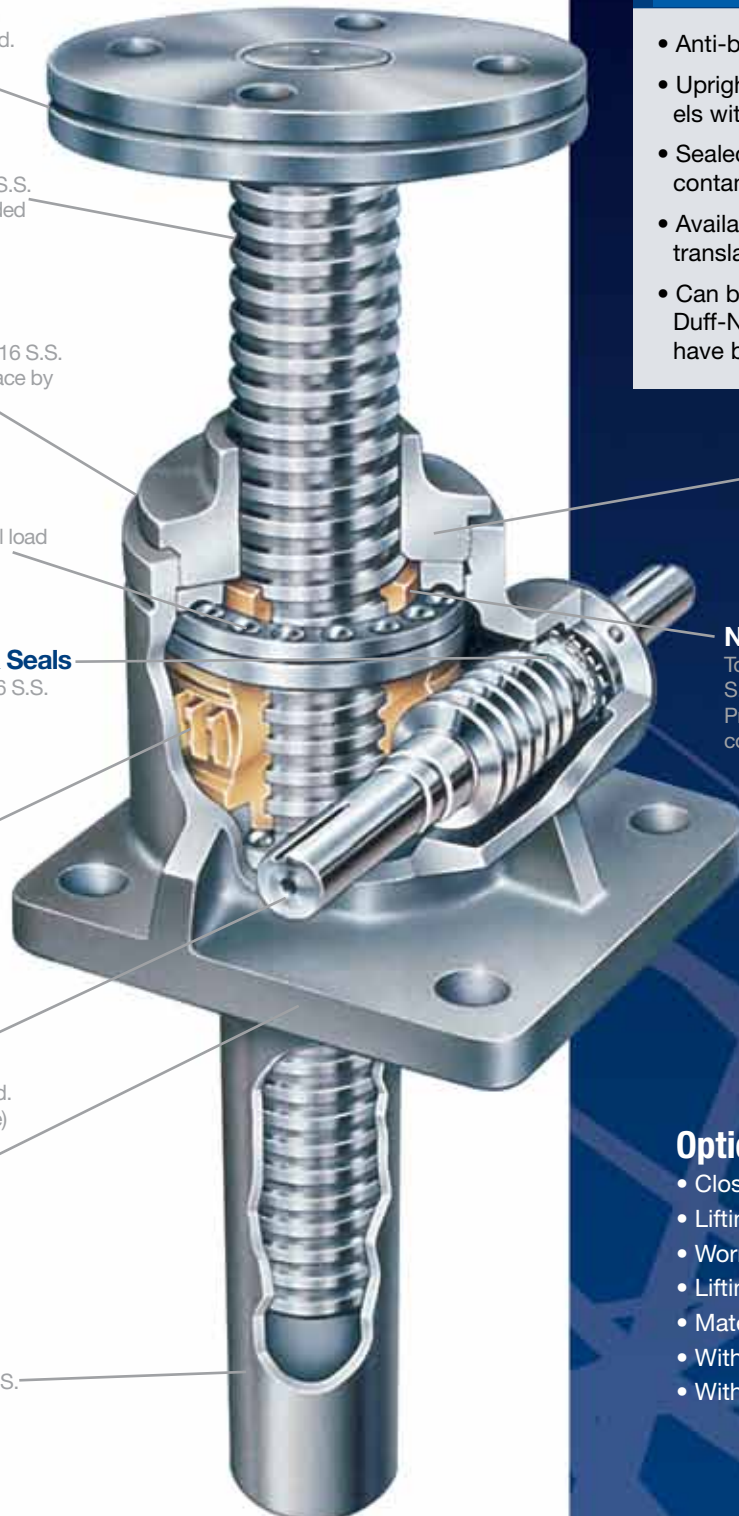

Features

- Anti-backlash models available.
- Upright and inverted rotating screw models with traveling nut available.
- Sealed gear cavity keeps water and other contaminants out.
- Available with keyed lifting screws for translating screw models.
- Can be retrofitted into applications where Duff-Norton non-stainless steel actuators have been previously used.

Guide Bushing
Bronze

Nitrile Rubber Seals
Top and bottom with 316 S.S. case and spring.
Protects gearcase from contamination.

Optional Special Features:

- Closed heights
- Lifting screw ends
- Worm shaft extensions
- Lifting screw thread pitches
- Materials
- With stop nuts
- With boots

MACHINE SCREW ACTUATORS STAINLESS STEEL

Model Numbering System

FL - TSM - 9002 - 6 - 1R

Model Prefix

R - Reducer
F - C-face Adapter
H - Hand Wheel
L - Limit Switch
E - Encoder
J - Rotary Counter

Screw End & Configuration

T - Threaded End
C - Clevis End
M - Top Plate
P - Plain End

K - Keyed Screw
CC - Double Clevis

D - Inverted Rotating
U - Upright Rotating

Series & Capacity No.

Series:

Machine Screw
(90xx, 18xx, 70xx, 25xx)
Special MS
(100xx, 20xx, 80xx, 35xx)

(1800 series base configurations are available only on 2 and 50 Ton models)

Capacities:

Upright model suffixes end with the capacity number.
Inverted model suffixes lower the capacity number by one digit.
Rotating model suffixes raise the capacity number by one digit.

SM - Base Model

Travel

1" increment travels are always represented using the exact travel amount.

Travels with fractional lengths are quoted using that length, but are serialized when the order is processed.

Serialized digits in this position may also be used for other models containing special features.

Model Suffix

B - Boot
L - Single End Worm Ext. Left
R - Single End Worm Ext. Right
1 - Optional Ratio #1
2 - Optional Ratio #2
X - Supplied without cover pipe

Stainless Steel Actuator Performance Table

Performance Table Instructions – pgs. 17, 39, 45, 53 and 74

When reviewing any Duff-Norton Actuator Performance Specifications Table, as part of the process of selecting the best-suited actuator for your application, there are several important worm-gear ratios to consider.

Standard Ratio – is frequently chosen when higher speeds and efficiency ratings are desired.

Optional Ratio – is frequently chosen when the application requires higher lifting capacities, lower speeds, or to ease the use of a handwheel.

Numeric Ratio – is frequently chosen for applications requiring fine adjustments, higher lifting capacities, lower speeds, the easy use of a handwheel, self locking applications, and also offers the benefit of an even number of worm input turns per inch of stroke.

Machine Screw Actuator Stainless Steel										
Capacity (Tons) - 17-4PH Worm		2	5	10	15	20	25	35	50	100
Capacity (Tons) - 316 SS Worm		0.67	1.66	3.33	5.00	6.66	8.33	11.66	16.66	33.33
Lifting Screw	Diameter (in)	1	1 1/2	2	2 1/4	2 1/2	3	3 3/4	4 1/2	6
	Pitch (Std. & Op)	0.250	0.375	0.500	0.500	0.500	0.666	0.666	0.666	0.750
	Pitch (Numeric)	—	0.250	0.250	0.250	0.250	0.320	0.320	0.320	—
	Type	ACME	ACME	ACME	ACME	ACME	ACME	ACME	ACME	Mod. Sq.
Worm Gear Ratios	Std.	6:1	6:1	8:1	8:1	8:1	10 2/3:1	10 2/3:1	10 2/3:1	12:1
	Optional No. 1	24:1	24:1	24:1	24:1	24:1	32:1	32:1	32:1	36:1
	Optional No. 2	12:1	12:1	—	—	—	—	—	—	—
	Numeric	25:1	25:1	25:1	25:1	25:1	32:1	32:1	32:1	—
Turns of Worm for 1" Stroke	Std.	25	17	17	17	17	16	16	16	16
	Optional No. 1	100	67	50	50	50	48	48	48	48
	Optional No. 2	50	33	—	—	—	—	—	—	—
	Numeric	100	100	100	100	100	100	100	100	—
Worm Torque at No Load (in-lb)	Std.	5	10	20	20	30	40	50	100	200
	Optional No. 1	5	10	20	20	30	40	50	100	200
	Optional No. 2	5	10	—	—	—	—	—	—	—
	Numeric	5	10	20	20	30	40	50	100	200
Maximum Horsepower per Actuator	Std.	2	4	5	5	5	8	8	15	25
	Optional No. 1	1/2	3/4	1 1/2	1 1/2	1 1/2	2 1/2	2 1/2	6	11
	Optional No. 2	3/4	2	—	—	—	—	—	—	—
	Numeric	1/2	3/4	1 1/2	1 1/2	1 1/2	2 1/2	2 1/2	6	11
Worm Torque at Full load (in-lb) 17-4PH Worm	Std.	120	450	750	1430	2050	2700	4000	7500	16000
	Optional No. 1	50	185	400	820	1170	1700	2400	4200	8600
	Optional No. 2	75	275	—	—	—	—	—	—	—
	Numeric	48	175	370	640	925	1500	2411	4040	—
Worm Torque at Full load (in-lb) 316SS Worm	Std.	42	150	253	471	676	926	1366	2566	5466
	Optional No. 1	19	66	141	276	394	593	833	1466	3000
	Optional No. 2	27	95	—	—	—	—	—	—	—
	Numeric	25	57	67	109	144	336	350	619	—
Efficiency Rating (%) - 17-4PH Worm	Std.	22.1	22.1	26.5	20.9	22.0	22.4	17.4	13.3	12.4
	Optional No. 1	13.3	13.4	16.6	12.1	12.8	11.8	9.7	7.9	7.7
	Optional No. 2	17.7	18.1	—	—	—	—	—	—	—
	Numeric	13.3	9.1	8.6	7.5	6.9	5.3	4.6	3.9	—
Efficiency Rating (%) - 316SS Worm	Std.	20.3	21.1	25.1	20.3	18.8	17.9	17.0	12.9	12.1
	Optional No. 1	10.9	12.0	15.0	11.5	10.7	9.3	9.3	7.5	7.4
	Optional No. 2	15.5	16.8	—	—	—	—	—	—	—
	Numeric	10.9	8.0	7.5	5.8	5.4	4.5	4.5	3.6	—
Key Torque (in-lb) - 17-4PH Worm	Std. & Opt.	460	1750	4700	7580	10625	14000	26500	47110	118200
	Numeric	460	1599	4077	6645	9369	11474	18561	30970	—
Key Torque (in-lb) - 316SS Worm	Std. & Opt.	153	581	1565	2527	3538	4665	8828	15697	39396
	Numeric	211	460	551	959	1199	2328	2358	4087	—
Weight with 6" Stroke (Raise) (lb)		17	35	52	66	93	160	240	410	1200
Weight per Additional 1" Stroke (Raise) (lb)		0.3	0.9	1.4	1.5	2.6	2.5	3.7	5.5	9.0

*For loads from 25% to 100% of actuator capacity, torque requirements are approximately proportional to the load.
 Note: Contact Duff-Norton Customer Service for motorized performance.

MACHINE SCREW ACTUATORS STAINLESS STEEL

2 to 100 Ton Capacity

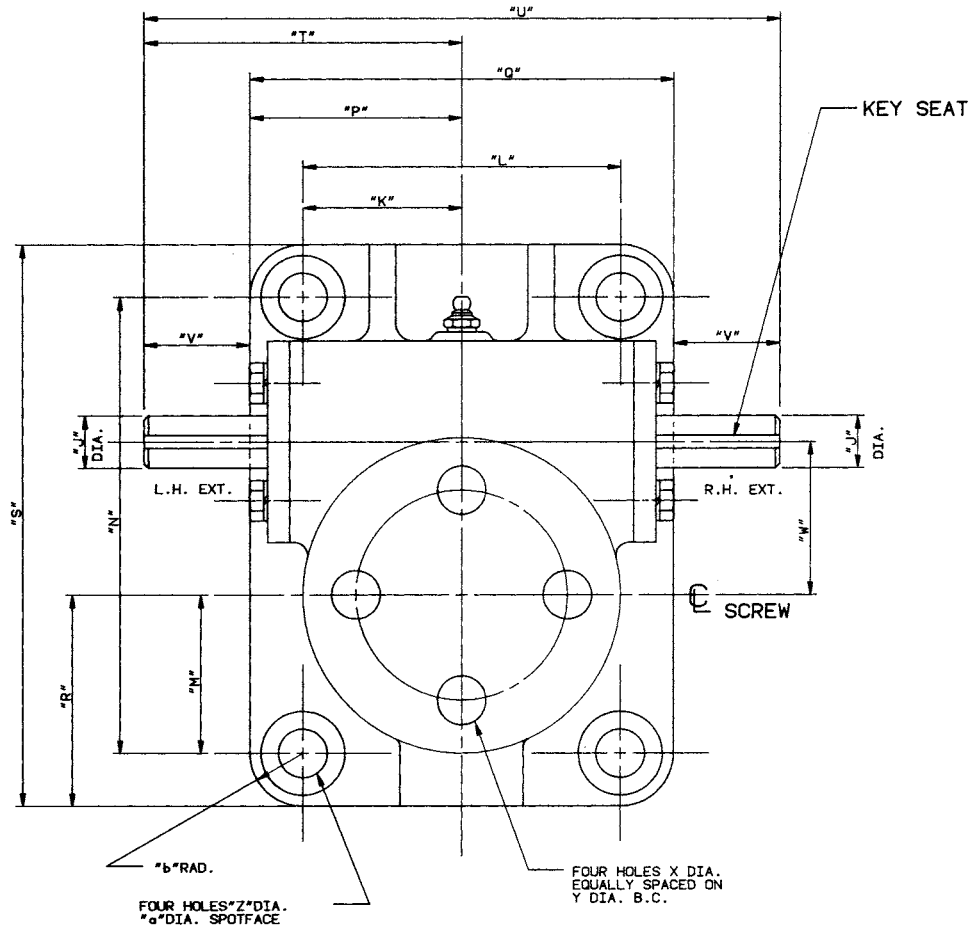

Machine Screw Actuator Stainless Steel

Product Specifications	17 - 4 PH		316 SS		A	B	C	D	E	F	G	H	J	K	L	M
	Worm Cap.	Worm Capacity (Tons)														
	(Tons)	Sustaining	Operating													
2 (1800 Series)	2	.67	5.50	4.56	Travel	.50	1.750	1.66	4.25	.50	.500	3.00	6.00	1.00		
2 (9000 Series)	2	.67	5.50	4.56	Travel	.50	1.750	1.66	4.25	.50	.500	1.56	3.13	1.93		
5	5	1.66	7.50	5.88	Travel	.50	2.250	2.38	4.50	.60	.749	2.25	4.50	2.25		
10	10	3.33	7.75	5.62	Travel + 3/8	.50	2.250	2.88	5.75	.94	1.000	2.88	5.75	2.00		
15	15	5.00	8.00	6.31	Travel + 9/16	.63	2.750	2.88	5.75	.94	1.000	3.00	6.00	2.50		
20	20	6.66	10.25	7.13	Travel + 1/2	.75	3.250	3.50	5.75	.94	1.000	3.00	6.00	3.00		
25	25	8.33	11.75	9.75	Travel + 1/4	1.00	4.000	4.50	8.50	.94	1.375	3.75	7.50	3.75		
35	35	11.66	12.50	9.56	Travel + 1/4	1.25	4.000	4.50	10.50	1.31	1.375	3.75	7.50	4.50		
50 (1800 Series)	50	16.66	13.50	11.38	Travel + 5/8	1.25	4.750	5.63	11.25	1.25	1.500	8.00	16.00	3.00		
100	100	33.33	24.00	18.50	Travel + 1/2	1.50	6.000	7.00	14.00	2.94	1.750	10.00	20.00	5.75		

Dimensions are subject to change without notice.

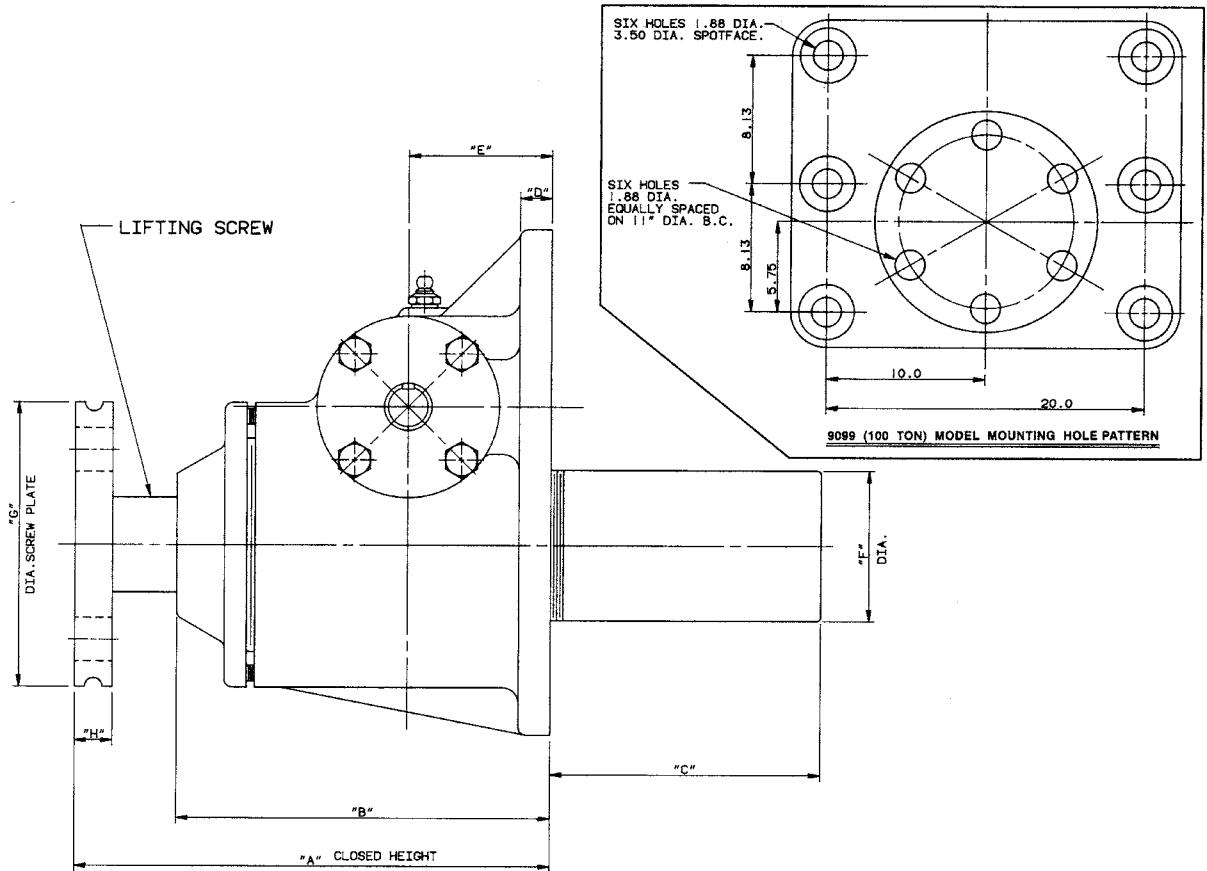

Machine Screw Actuator Stainless Steel

N	P	Q	R	S	T	U	V	W	X	Y	Z	a	b	Keyseat	Lifting Screw (Dia./Pitch)
2.00	3.50	7.00	1.75	3.50	3.50	7.00	1.12	1.702 +.003/-0.000	.41	3.00	.41	.75	.5	.125 x .060 x 1.00 LG.	1.00 x .250
5.25	2.06	4.13	2.42	6.25	3.50	7.00	1.12	1.702 +.003/-0.000	.41	3.00	.41	.88	.38	.125 x .060 x 1.00 LG.	1.00 x .250
6.50	3.00	6.00	3.00	8.00	4.50	9.00	1.50	2.188 +.002/-0.000	.69	3.00	.69	1.19	.75	.188 x .094 x 1.25 LG.	1.50 x .375
7.00	3.75	7.50	2.88	8.75	5.50	11.00	1.80	2.598 +.003/-0.000	.81	4.13	.81	1.31	.88	.250 x .125 x 1.50 LG.	2.00 x .500
7.50	3.88	7.75	3.38	9.25	5.50	11.00	1.80	2.598 +.003/-0.000	.81	4.13	.81	1.38	.88	.250 x .125 x 1.50 LG.	2.25 x .500
8.75	4.13	8.25	4.13	11.00	5.50	11.00	1.50	2.598 +.003/-0.000	.81	4.13	1.12	1.75	1.13	.250 x .125 x 1.50 LG.	2.50 x .500
11.00	5.13	10.25	5.13	13.75	7.00	14.00	2.30	3.750 +.006/-0.000	1.06	6.00	1.38	2.13	1.38	.313 x .156 x 2.00 LG.	3.00 x .666
12.50	5.13	10.25	6.00	15.50	7.00	14.00	2.10	3.750 +.006/-0.000	1.62	7.75	1.62	2.63	1.38	.313 x .156 x 2.00 LG.	3.75 x .666
6.00	9.88	19.75	4.88	9.75	11.00	22.00	4.40	5.313 +.003/-0.000	1.38	8.75	1.88	3.25	1.88	.375 x .188 x 2.25 LG.	4.50 x .666
16.26	12.25	24.50	8.00	20.75	11.50	23.00	3.40	7.500 +.003/-0.000	1.88	11.00	1.88	3.50	2.25	.500 x .250 x 3.00 LG.	6.00 x .750

Dimensions are subject to change without notice.

MACHINE SCREW ACTUATORS STAINLESS STEEL

Standard Screw End Dimensions

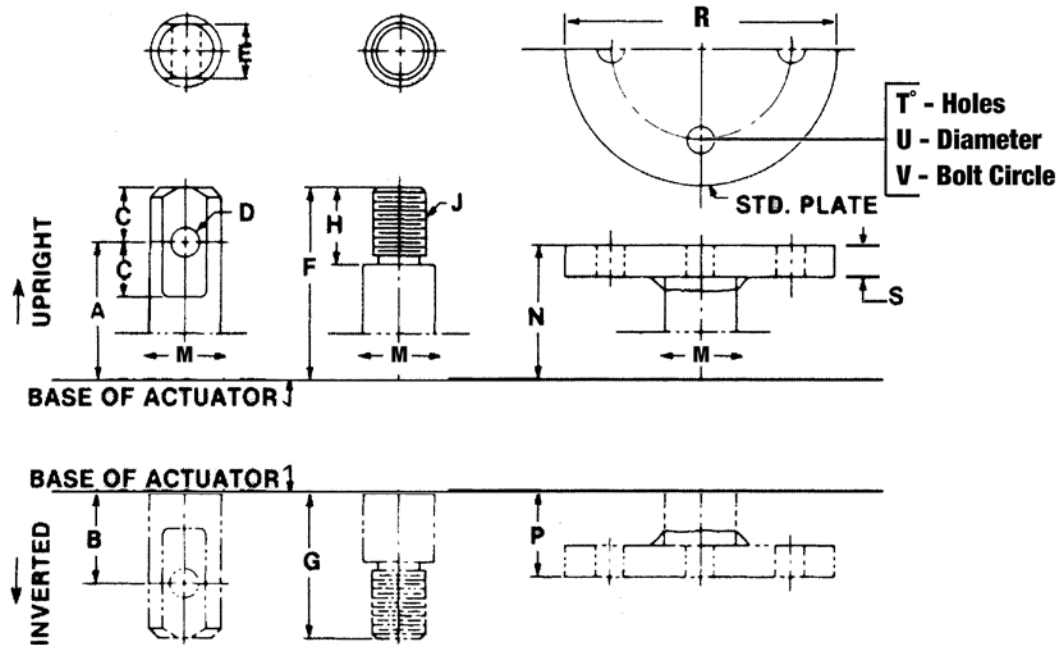

Machine Screw Actuator Stainless Steel Screw End

Capacity	A**	B**	C	D	E	F**	G**	H	J	M	N**	P**	R	S	T	U	V
2 Ton SMS	5 1/4	1 3/4	3/4	13/32	3/4	6	2 1/2	1 1/8	3/4"-10UNC-2A	1	5 1/4	1 3/4	4 1/4	7/16	4	13/32	3
5 Ton SMS	7	2 1/2	1	21/32	1	8	2 1/2	1 1/8	1"-8UNC-2A	1 1/2	7 1/2	2 1/2	4 1/2	5/8	4	11/16	3
10 Ton SMS	7 1/2	3	1 1/4	25/32	1 1/4	9 1/4	4 1/4	1 5/8	1 1/2"-6UNC-2A	2	7 3/4	2 3/4	5 3/4	15/16	4	13/16	4 1/8
15 Ton SMS	8 1/2	3	1 1/4	29/32	1 1/2	10 1/4	4 1/4	2	1 3/4"-5UNC-2A	2 1/4	8 1/2	2 3/4	5 3/4	15/16	4	13/16	4 1/8
20 Ton SMS	10	3 1/2	1 1/2	1 1/32	1 3/4	12 1/2	5	2 1/4	2"-4 1/2UNC-2A	2 1/2	10 1/4	3	5 3/4	15/16	4	13/16	4 1/8
25 Ton SMS	12	4	1 3/4	1 9/32	2 1/4	14 1/2	5 3/4	3 1/4	2 1/2"-4-UNC-2A	3	11 3/4	3	8 1/2	15/16	4	1 1/16	6
35 Ton SMS	13	5	2	1 17/32	2 1/2	15 1/2	7	3 3/4	3 1/4"-4UNC-2A	3 3/4	12 1/2	4	10 1/2	1 5/16	4	1 5/8	7 3/4
50 Ton SMS	15	5 1/2	2 1/2	1 21/32	3 1/4	18	8	4 1/4	4"4UNC-2A	4 1/2	13 1/2	3 1/2	11 1/4	1 1/4	4	1 3/8	8 3/4
100 Ton SMS	24	9	3	2 17/32	4 1/4	25	12	5	1 1/2"-12UNC-2A	6	24	12	14	2 15/16	6	1 7/8	11

**Closed dimensions may increase for actuator units supplied with bellows boots. Consult Customer Service.

Note: Lifting screws listed above are not keyed, and i.c. must be held to prevent rotation.

Keyed lifting screws and keyed anti-backlash models also available. Consult Customer Service.

ANTI-BACKLASH ACTUATORS

1/4 to 250 Tons

Why Anti-Backlash Control is Important

Even the best manufacturing processes produce clearances between a screw and a mating nut. In applications where loads may be in either direction, backlash can result from these clearances creating unacceptable movement in the controlled mechanism as loads change. These applications are common in the paper, plastic, film, sheet metal forming processes, satellite, or other load-reversing applications.

Such applications may be subjected to extreme vibrations. These vibrations can produce constant movement between the screw and lifting nut which can hammer the threads and cause premature wear.

To reduce this screw-to-nut backlash to an absolute minimum, Duff-Norton developed Anti-Backlash actuators. The design allows the backlash to be adjusted to a minimum value practical. As wear occurs, the actuator can be easily adjusted, without any disassembly, to return the backlash to its' original minimum value.

Features

- The industry's best backlash control
- A dual role as an internal safety nut
- Available with standard, optional, and numeric ratios
- Available in stainless steel for most capacities
- Precise motion control
- The ability to lock and hold a load, thereby eliminating the need for brake motors required for some applications
- Available on 1/4 to 250 Ton models



ANTI-BACKLASH ACTUATORS

Model Numbering System

FL - TKM - 9402 - 6 - 1R

Model Prefix

R - Reducer
F - C-face Adapter
H - Hand Wheel
L - Limit Switch
E - Encoder
J - Rotary Counter

Screw End & Configuration

T - Threaded End
C - Clevis End
M - Top Plate
P - Plain End
K - Keyed Screw
CC - Double Clevis
D - Inverted Rotating
U - Upright Rotating
N - Numeric Ratio

Series & Capacity No.

Series:

Anti-Backlash
 (94xx, 48xx, 74xx, 4501)
 Special AB
 (104xx, 58xx, 84xx, 5501)

(1800 series base configurations are available only on 2 and 50 Ton models)

Small Capacity AB (45xx, 4555, 4625)
 Special Small AB (55xx, 5555, 5625)

Capacities:

Upright model suffixes end with the capacity number.
 Inverted model suffixes lower the capacity number by one digit. Rotating model suffixes raise the capacity number by one digit.

M - Base Model - Standard Material
SM - Base Model - Stainless Steel

Travel

1" increment travels are always represented using the exact travel amount.

Travels with fractional lengths are quoted using that length, but are serialized when the order is processed.

Serialized digits in this position may also be used for other models containing special features.

Model Suffix

B - Boot
L - Single End Worm Ext. Left
R - Single End Worm Ext. Right
1 - Optional Ratio #1
2 - Optional Ratio #2
X - Supplied without cover pipe

B9003A TV - 10.50 - LX2 - BFL

Capacity

B9225A - 500 Lbs
B9250A - 1000 Lbs
B9003A - 3 Ton

Screw End

C - Clevis End Screw
CC - Double Clevis Ends
M - Top Plate Screw
P - Plain End Screw
T - Threaded End Screw

Travel

1" Incremental travels are always represented using the exact travel amount. Fractional lengths are represented and processed to the nearest 100ths.

Base Model

None - Upright Translating
D - Inverted Rotating
K - Keyed, anti-rotation
U - Upright Rotating
V - Inverted Translating

Key Accessories

B - Boot
E - Encoder
F - C-face Adapter
H - Hand Wheel
J - Rotary Counter
L - Limit Switch
R - Reducer

Model Suffix

L - Single End Worm Extension Left
N - Numeric Gear Ratio - 100 turns/inch
R - Single End Worm Extension Right
X - Supplied without Cover Pipe
1 - Alternate Gear Ratio #1
2 - Alternate Gear Ratio #2

Alphabet characters representing features and suffixes should always be used in alphabetic order to avoid questions of hierarchy.

Models for actuators with specialized features will have a serialized suffix such as B9225T-0001.

ANTI-BACKLASH ACTUATORS

How it Works

How Anti-Backlash Works

When the screw (1) is under a compression load, the bottom of its thread surfaces are supported by the top thread surfaces of the worm gear (2). The anti-backlash nut (3), being pinned to the worm gear and floating on these pins and being adjusted downward by the shell cap, forces its bottom thread surfaces against the upper thread surfaces of the lifting screw at point (B). Thus, backlash between the worm gear threads and the lifting screw threads is reduced to a regulated minimum.

When wear occurs in the worm gear threads and the Anti-backlash nut thread, the load carrying thickness of the worm gear thread will be reduced. This wear will create a gap at point (B) and provide backlash equal to the wear on the threads.

Under a compression load, the lifting screw will no longer be in contact with the lower thread surface of the anti-backlash nut. Under this condition, backlash will be present when a tension load is applied.

The anti-backlash feature can be maintained simply by adjusting the shell cap until the desired amount of backlash reduction is achieved. This will reduce the separation (A) between the anti-backlash nut and the worm gear and will reduce the backlash between the worm gear threads and the lifting screw to the desired minimum value.

To avoid binding and excessive wear, do not adjust lifting screw backlash to less than .0005”.

When separation (A) has been reduced to zero, the wear limit has been reached. Replace the worn gear and backlash nut set at this point. This feature acts as a built in safety device.

Note: Use anti-backlash as a safety device or to provide wear indication for critical applications. Keyed anti-backlash models may require (A) key adaptor, which projects below jack base. See pg. 47 for dimensions.

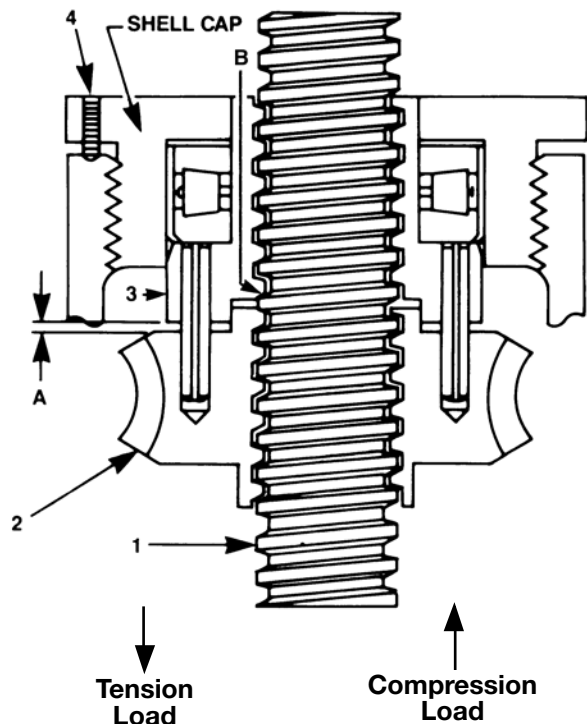

Key Adaptor Dimensions for Anti-Backlash Actuators

Keyed Anti-Backlash Inverted

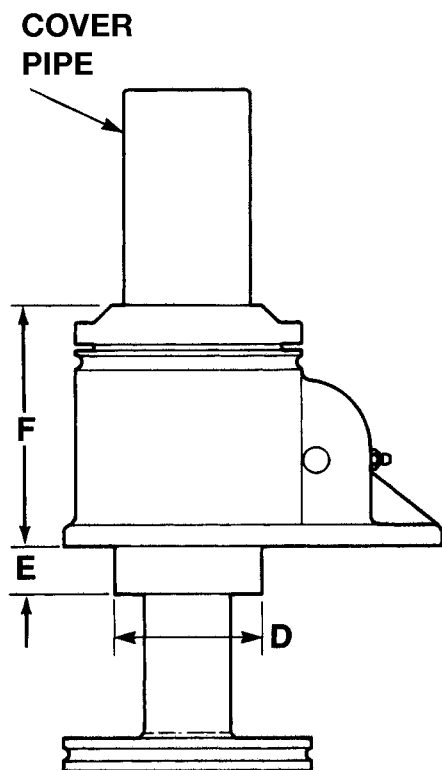

Keyed Anti-Backlash Upright

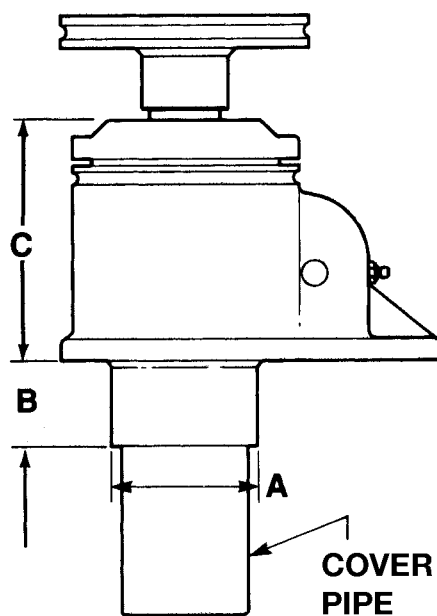

Key Adaptor Dimensions for Anti-Backlash Actuator

Actuator Capacity (Tons)	Upright A Dia. (in)	Upright B (in)	Upright C (in)	Inverted D Dia. (in)	Inverted E (in)	Inverted F (in)
1/4 & 1/2	1.66	Pipe Length	2.38	1.25	.81	2.88
1	1.66	.75	3.84	1.50	.38	3.38
2	2.25	1.25	3.88	2.25	.63	3.88
3	2.25	1.25	4.34	2.25	.63	4.34
5	2.75	1.75	5.44	2.75	.88	5.44
10	3.38	2.00	5.75	3.38	1.13	5.75
15	3.63	2.00	6.13	3.63	1.25	6.13
20	4.00	1.50	7.75	4.00	1.00	7.75
25	5.50	2.25	9.69	5.50	1.25	9.69
35	6.50	2.38	9.44	6.50	1.25	9.44
50	7.00	3.00	11.75	7.00	3.00	11.75

Anode Jacks

Features

- Oversized worm and gear set
- Heavy duty load bearing
- Heavy duty seals
- High temperature resistant grease
- Translating or rotating models available

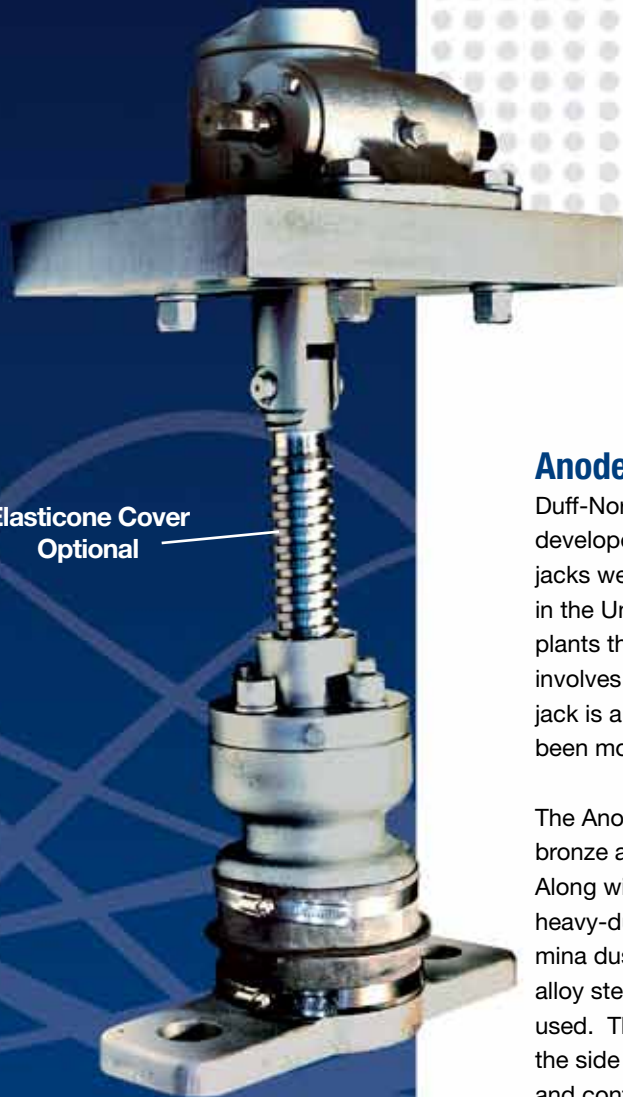

Elasticone Cover
Optional

**Inverted Rotating Style
Anode Jack**



**Inverted Translating
Style Anode Jack**

Anode Jacks

Duff-Norton was the originator of the Anode Jack, which was developed in partnership with the Aluminum Industry. Our jacks were used in the first commercial aluminum-making plant in the United States and continue to be used in aluminum plants throughout the world. The alumina smelting process involves high temperatures and loads. The Duff-Norton anode jack is a heavy-duty version of our standard actuator, and has been modified for each smelting facility's specific application.

The Anode Jack's worm gears are made of wear resistant bronze and are up to 40% larger than our standard versions. Along with the larger worm gears are larger bearings and heavy-duty seals. Sealing is very important because the alumina dust is very abrasive. Anode jacks use only heat-treated alloy steel worms. Additionally, high temperature grease is used. These jacks have a large overload capacity to handle the side loading stresses caused by the thermal expansions and contractions of the frames. They are also built to take the compressive overloads caused by occasional highjacking of the frames and frozen pots.

www.duffnorton.com • Ph: (800) 477-5002 • Fax: (704) 588-1994

In addition to these jacks, Duff-Norton can also supply anode-jacking arrangements, which include the motor, reducer, shafting and couplings for your complete system requirements.

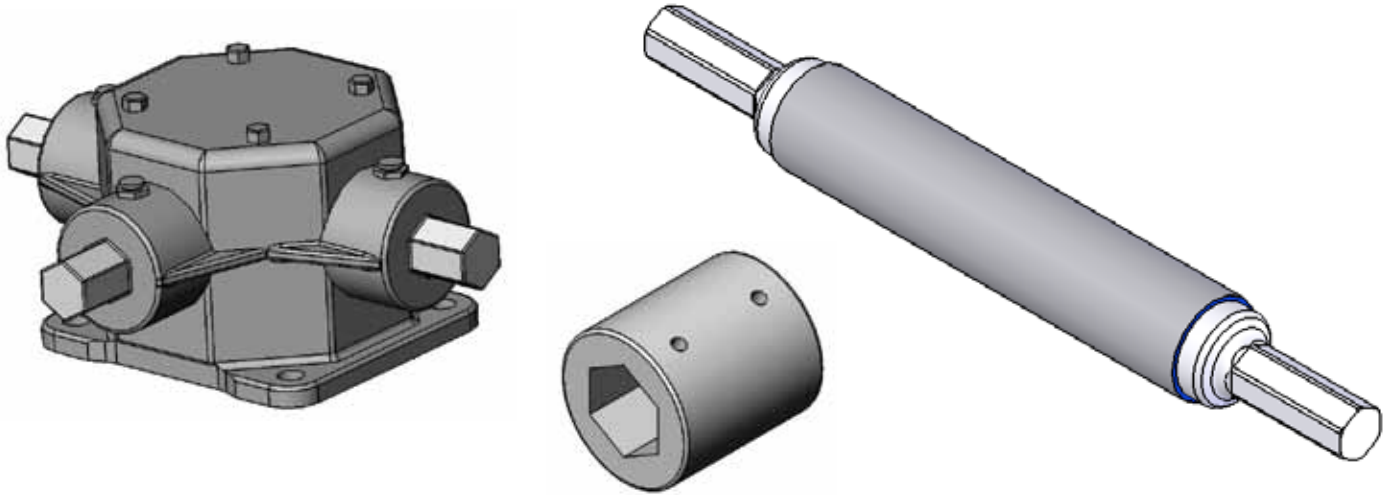

**Oversized Clevis,
Knurled Ring, &
Cover Pipe**



**Heavy Duty Worm Seals
& Grease Fittings**



**Trunnion Base &
Upper Yoke**



**Cover Pipe with
Heavy Duty Cap**



**Special Corrosion
Resistant Paint**



Hex Worm Shafts



**Connecting Link,
Clevis Pinned
Screw, & Lifting Nut**

MACHINE SCREW ACTUATORS

Micro-Miniature



Features

- Allows for extremely fine adjustment.
- Corrosion-resistant.
- Equipped with anti-backlash nuts to minimize vertical backlash between the screw and worm gear nut.
- Actuators up to 1,000 lbs.
- Also available in stainless steel. Standard model has anodized aluminum shell cap and housing with stainless steel worm and lifting screws. Also available with sealed 316 stainless steel shell cap, housing, worm and lifting screw.
- Manual operation is accomplished with an easy-to-use hand knob. The dial indicator is protected by a removable clear plastic cover.
- Dial indicators available upon request. Indicate preference when ordering.
- Part No. SK-3554-46 - Balanced dial reading 0-50-0 in .001" graduations with revolution counter.
- Part No. SK-3554-83 - Continuous dial reading 0-100 in .001" graduations with revolution counter.

Micro-Miniature Actuator								
Specifications	Model No.	Rated Capacity	Screw Dia.	Turns of Worm for 1/2" Raise	No Load Torque	Lifting Torque at Full Load	Worm Gear Ratio	Shell Cap and Housing
	B9225MM-xxx	1000 lbs.	.625	500	2 In.-Lbs.	18 In.-Lbs.	20:1	Aluminum
	B9225MMS-xxx	1000 lbs.	.625	500	2 In.-Lbs.	18 In.-Lbs.	20:1	Stainless Steel

Note: The load bearings inside stainless steel actuators are not stainless steel.

Specifications

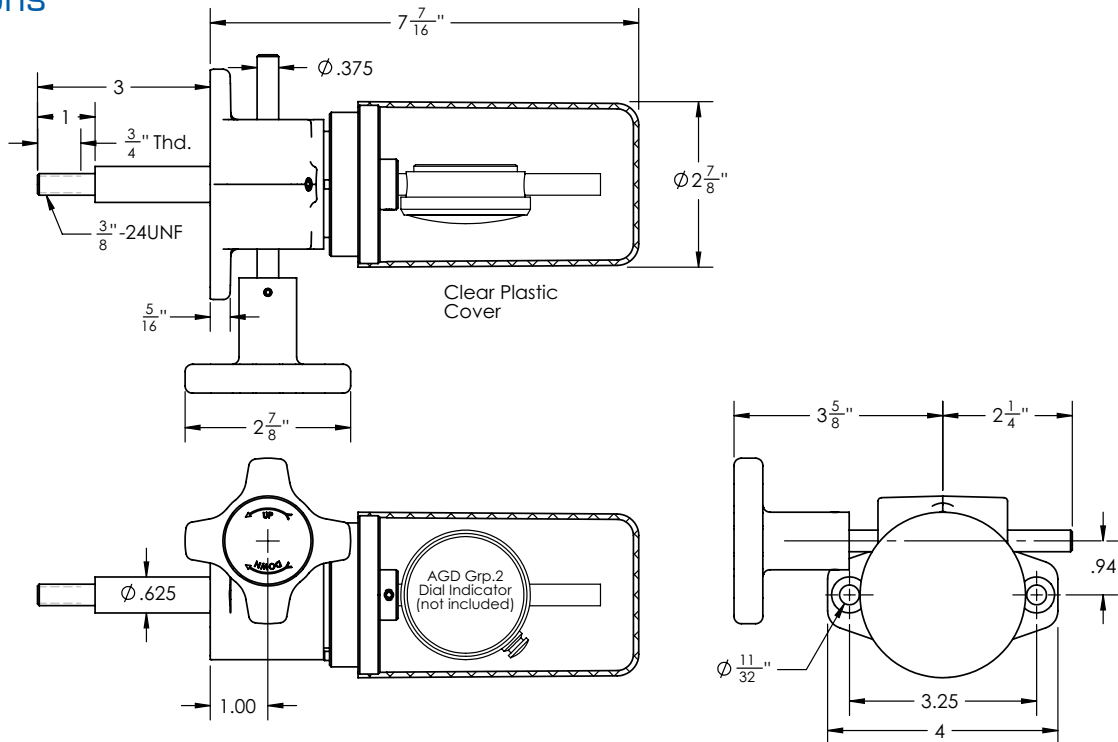

Dimensions are subject to change without notice

www.duffnorton.com • Ph: (800) 477-5002 • Fax: (704) 588-1994

BALL SCREW

ACTUATORS

1/2 to 50 Tons

Features

- Move loads and apply force more efficiently than other mechanical actuators.
- Permit faster operation and longer life under load.
- Require less power by reducing screw friction.
- Permit synchronization of multiple units.
- Capacity from 1/2 to 50 Tons.
- Handles full load in tension or compression.
- 40 models available.

Lifting Screw

Standard with threaded end.

Shell Cap

Adjustable to take end play out of bearings. Locked into place by set screws.

Ball Nut

Equipped with return tubes for continuous recirculation of steel balls. Threaded and secured to worm gear.

Worm Gear

Wear resistant bronze. Accurately hobbled for greater gear contact.

Load Bearings

Top and bottom to take loads in either direction.

Worm

Available with double or single shaft extension. Clockwise rotation of this end raises load on all actuator models except 50-ton ball screw actuator units.

Coverpipe

Protects lifting screw threads.

Stop Disc

This is not a power stop.

Thrust Bearing and Grease Seals

At each end of worm. 1/2-Ton models do not have seals.

Housing

Aluminum on 1/2 and 1 Ton models, ductile iron on 2-Ton through 10-Ton models cast steel on 20-Ton through 50-Ton models.

BALL SCREW ACTUATORS

Model Numbering System

FL - TKM - 9802 - 6 - 1R

Model Prefix

- R - Reducer
- F - C-face Adapter
- L - Limit Switch
- E - Encoder
- J - Rotary Counter

Screw End & Configuration

- T - Threaded End
- C - Clevis End
- M - Top Plate
- P - Plain End
- K - Anti-rotation Screw
- CC - Double Clevis
- D - Inverted Rotating
- U - Upright Rotating

Series & Capacity No.

Series:

- Ball Screw (98xx, 28xx, 78xx)
- Special BS (108xx, 38xx, 88xx)

(2800 series base configurations are available only on 1/2, 1, 2, 3 and 50 Ton models)

Capacities:

Upright model suffixes end with the capacity number.
Inverted model suffixes lower the capacity number by one digit. Rotating model suffixes raise the capacity number by one digit.

1/2 & 1 Ton models use ball screw lead measurement in place of capacity information. These numbers change as described above based on actuator configuration.

M - Base Model

Travel

1" increment travels are always represented using the exact travel amount.

Travels with fractional lengths are quoted using that length, but are serialized when the order is processed.

Serialized digits in this position may also be used for other models containing special features

Model Suffix

- B - Boot
- L - Single End Worm Ext. Left
- R - Single End Worm Ext. Right
- 1 - Optional Ratio #1
- 2 - Optional Ratio #2
- X - Supplied without cover pipe

B9863A TV - 10.50 - LX2 - BFL

Capacity

B9863 - 1000 Lbs

Screw End

- C - Clevis End Screw
- CC - Double Clevis Ends
- M - Top Plate Screw
- P - Plain End Screw
- T - Threaded End Screw

Travel

1" Incremental travels are always represented using the exact travel amount. Fractional lengths are represented and processed to the nearest 100ths.

Base Model

- None - Upright Translating
- D - Inverted Rotating
- K - Keyed, anti-rotation
- U - Upright Rotating
- V - Inverted Translating

Key Accessories

- B - Boot
- E - Encoder
- F - C-face Adapter
- H - Hand Wheel
- J - Rotary Counter
- L - Limit Switch
- R - Reducer

Model Suffix

- L - Single End Worm Extension Left
- N - Numeric Gear Ratio - 100 turns/inch
- R - Single End Worm Extension Right
- X - Supplied without Cover Pipe
- 1 - Alternate Gear Ratio #1
- 2 - Alternate Gear Ratio #2

Alphabet characters representing features and suffixes should always be used in alphabetic order to avoid questions of hierarchy.

Models for actuators with specialized features will have a serialized suffix such as B9225T-0001.

Ball Screw Actuator Performance Table



Ball Screw Actuator		1/2	1	2	2	3	5	5	10	10	20	20	25	50
Capacity (Tons)				(HL)			(HL)		(HL)		(HL)			
Max. Speed Cface Driven (in/min)** (page 116)		—	—	287.5	72.0	118.5	287.5	136.5	215.5	102.0	215.5	108.0	81.0	—
Max. Speed Red. Driven (in/min)** (page 110-111)		—	—	57.5	14.4	23.7	57.4	27.2	43	20.4	43.1	21.6	20.1	33.4
Dimensional Information Shown on (page 113)		52	53	54-59	54-59	60-61	62	63	64	65	66	66	67	68-69
Lifting Screw	Diameter (in)	5/8	3/4	1	1	1 11/64	1 1/2	1 1/2	1 1/2	1 1/2	2 1/4	2 1/4	3	4
	Lead (in)	0.200	0.200	1.000	0.250	0.413	1.000	0.474	1.000	0.474	1.000	0.500	0.660	1.000
Worm Gear Ratios	Std.	5:1	5:1	6:1	6:1	6:1	6:1	6:1	8:1	8:1	8:1	8:1	10 2/3:1	10 2/3:1
	Optional No. 1	20:1	20:1	24:1	24:1	24:1	24:1	24:1	24:1	24:1	24:1	24:1	24:1	32:1
	Optional No. 2	—	—	12:1	12:1	12:1	12:1	12:1	—	—	—	—	—	—
Turns of Worm for 1" Stroke	Std.	25	25	6	24	14.526	6	12.667	8	16.889	8	16	16.16	10.67
	Optional No. 1	100	100	24	96	58.106	24	50.667	24	50.667	24	48	48.48	32
	Optional No. 2	—	—	12	48	29.053	12	25.334	—	—	—	—	—	—
Worm Torque at No Load (in-lb)	Std.	0.5	2	10	3	5	20	10	20	15	50	40	40	90
	Optional No. 1	0.5	2	10	3	5	20	10	20	15	50	40	40	90
	Optional No. 2	—	—	10	3	5	20	10	—	—	—	—	—	—
Maximum Horsepower per Actuator	Std.	1/3	1/2	2	2	2	4	4	5	5	5	5	8	15
	Optional No. 1	1/6	1/4	1/2	1/2	1/2	3/4	3/4	1 1/2	1 1/2	1 1/2	1 1/2	2 1/2	6
	Optional No. 2	—	—	3/4	3/4	3/4	2	2	—	—	—	—	—	—
Starting Worm Torque at Full Load (in-lb)	Std.	10.5	22	180	50	110	500	220	800	350	1375	700	925	2700
	Optional No. 1	5.0	11	80	25	50	206	90	400	175	625	325	475	1500
	Optional No. 2	—	—	110	30	68	300	145	—	—	—	—	—	—
Running Worm Torque at Full Load (in-lb)	Std.	9.5	21	160	45	100	410	180	700	300	1270	650	825	2200
	Optional No. 1	4.0	10	70	20	45	183	80	290	150	570	300	425	1200
	Optional No. 2	—	—	100	25	60	270	125	—	—	—	—	—	—
Efficiency Rating (%)	Std.	67.0	60.6	66.3	58.9	65.7	64.7	69.8	56.8	62.8	62.7	61.2	59.7	67.8
	Optional No. 1	39.8	31.8	37.9	33.2	36.5	36.2	39.3	45.7	41.9	46.5	44.2	38.6	41.4
	Optional No. 2	—	—	53.0	53.1	54.8	49.1	50.3	—	—	—	—	—	—
Weight with 6" Stroke (Raise) (lb)		2.8	5	20	20	21	40	40	50	50	115	115	235	520
Weight per Additional 1" Stroke (Raise) (lb)		0.1	0.3	0.3	0.3	0.4	0.9	0.9	0.9	0.9	1.5	1.5	2.9	5.0
Hold Back Torque at Rated Load (ft-lb)	Std.	1	1	2	2	7	8	8	24	11	24	24	24	92
	Optional No. 1	0.5	0.5	0.5	0.5	0.5	0.5	0.5	0.5	0.5	2	2	2	33
	Optional No. 2	—	—	1	1	2	2	2	—	—	—	—	—	—
Key Torque (in-lb)		35	70	700	175	440	1800	850	3500	1700	7000	3500	6000	17700
Max Worm Speed at Full Load (rpm)	Std.	2001	1432	700	2521	1146	504	1146	394	900	229	450	545	350
	Optional No. 1	2101	1432	394	1261	630	229	525	236	540	151	291	332	252
	Optional No. 2	—	—	430	1576	695	420	869	—	—	—	—	—	—
Max Load at Full Horsepower and 1750 rpm (lb)	Std.	1150	1601	1459	5875	3830	2585	6384	4104	9855	3927	8489	14018	17250
	Optional No. 1	1223	1556	458	2729	1734	377	2126	1791	4878	280	1968	5751	8942
	Optional No. 2	—	—	680	3557	2096	1858	4595	—	—	—	—	—	—

Note: Hold Back Torque is retraining torque at the worm shaft to keep load from running down.

Lifting torques are proportional to load, down to 25% of rated load.

Note: See page 105 for Ball Screw and Nut Life Expectancy.

All actuator units can be supplied with standard raises up to 24 inches. Special raises up to 20 feet are available upon request. Closed height dimensions may increase for actuators supplied with bellows boots. See page 146-147.

BALL SCREW ACTUATORS

1/2 Ton Capacity

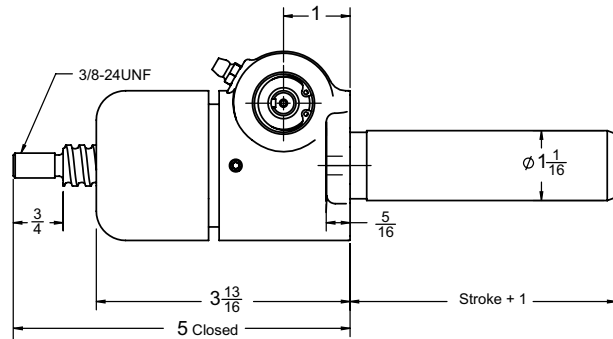
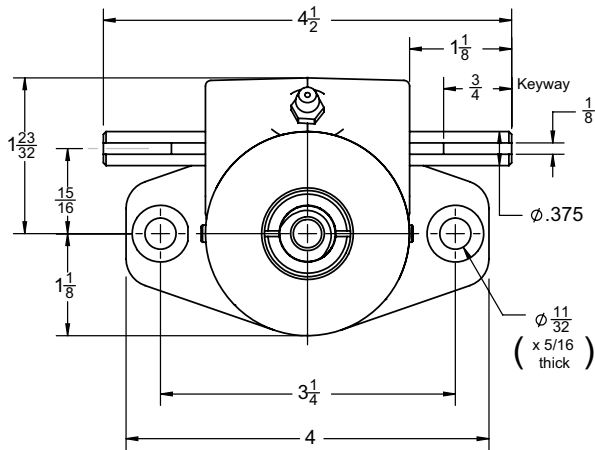

Upright: B9863T

.631 Diameter x .200 Lead Lifting Screws

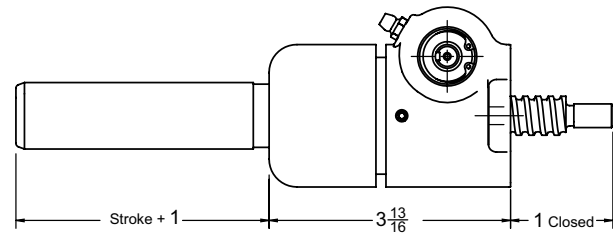
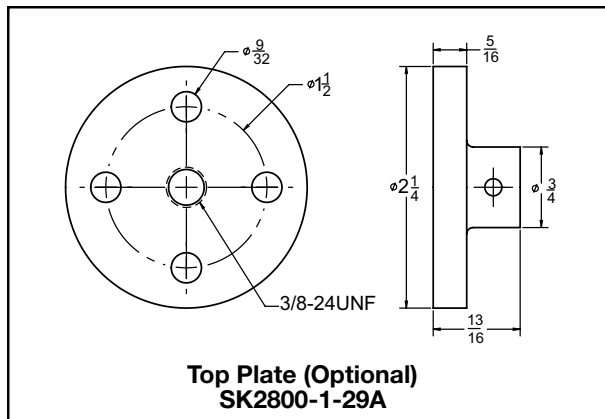

Inverted: B9863TV

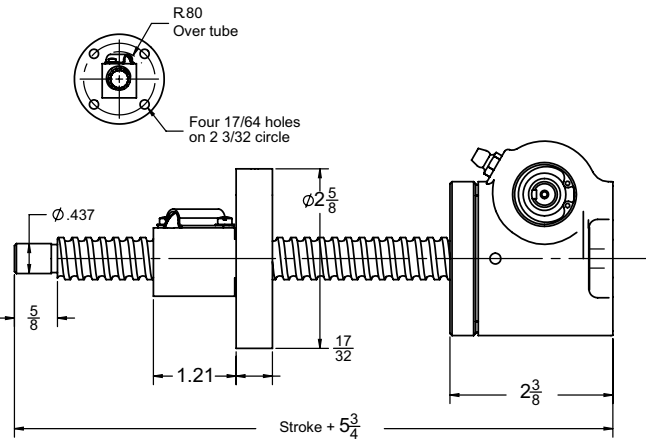
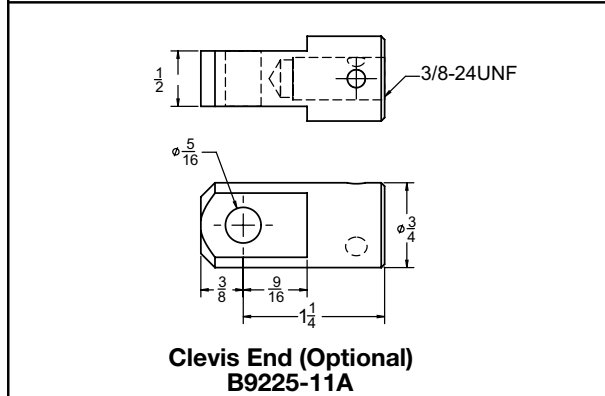

Upright Rotating: B9863U

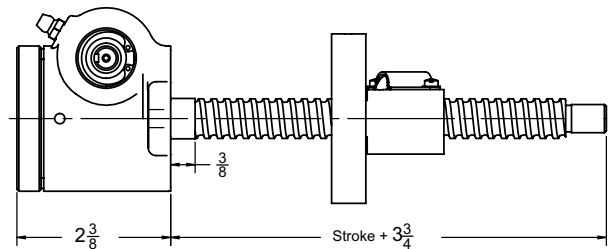
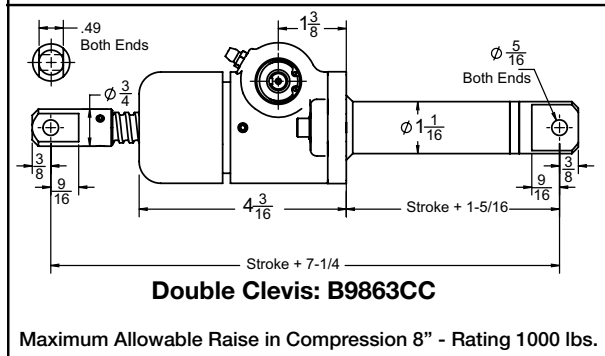

Inverted Rotating: B9863D

Note: Lifting screw is not keyed. Top should be secured to a lifting member to prevent rotation. When a Bellows Boot is required, see pages 146-147. Dimensions are subject to change without notice.

1 Ton Capacity

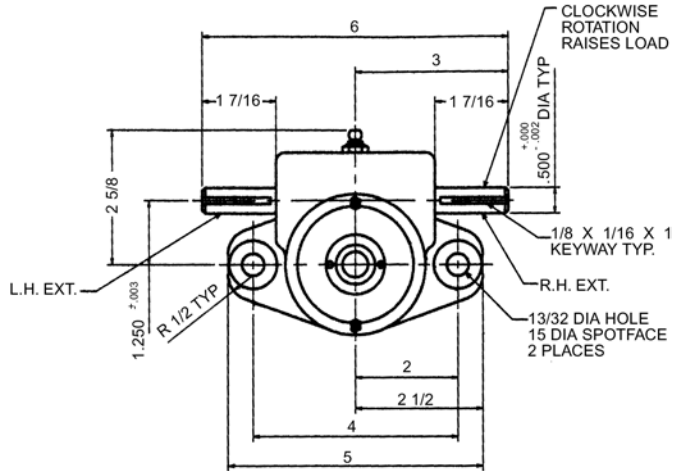

3/4" Diameter x .200 Lead Lifting Screw

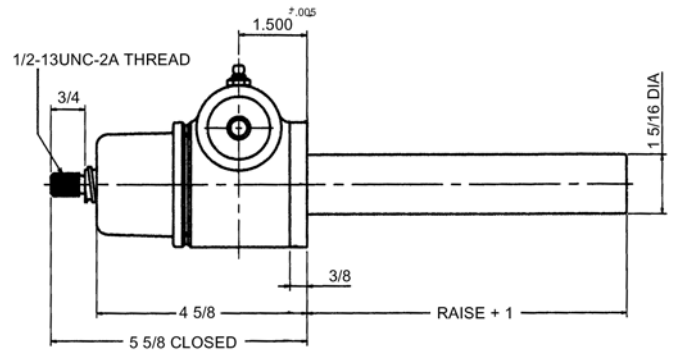

Upright: M-28750

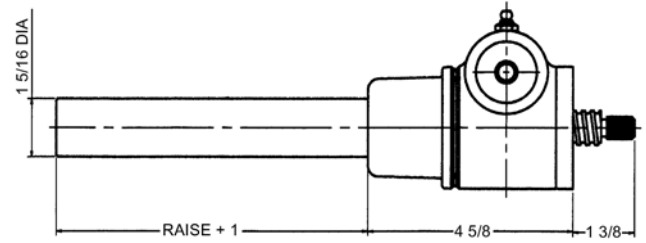

Inverted: M-28749

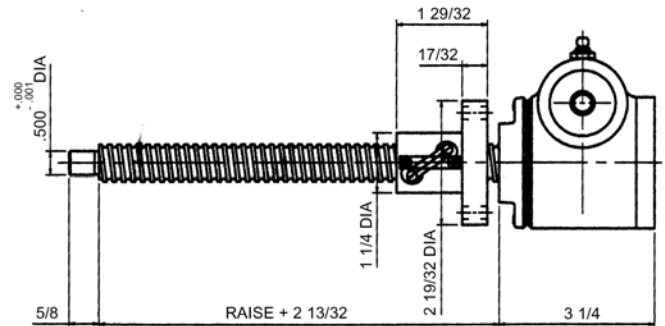
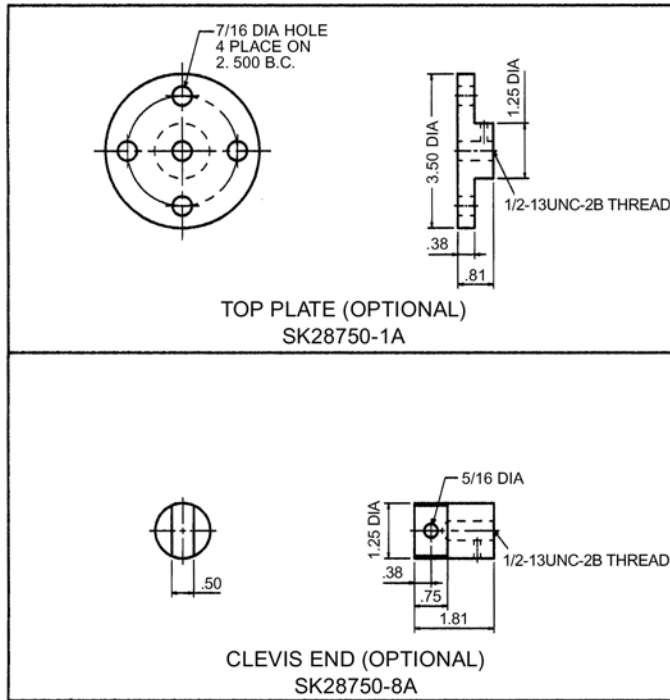

Upright Rotating: UM-28751

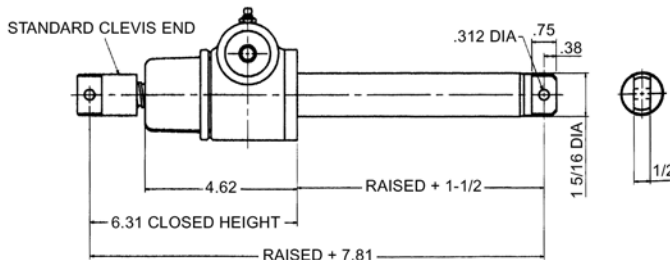

Inverted Rotating: DM-9051

Maximum allowable raise in compression 12" - Rating 2000lb.

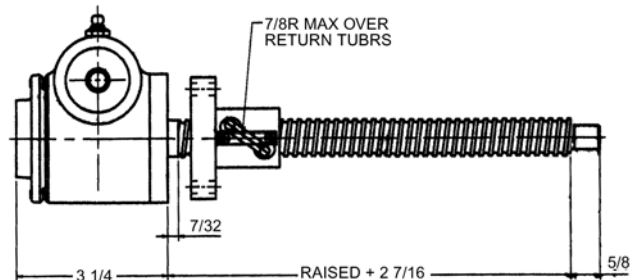

Inverted Rotating: DM-28751

Note: Lifting screw is not keyed. Top should be secured to a lifting member to prevent rotation. When a Bellows Boot is required, see pages 146-147. Dimensions are subject to change without notice.

BALL SCREW ACTUATORS

2 Ton Capacity - 1" Lead, 9800 Series

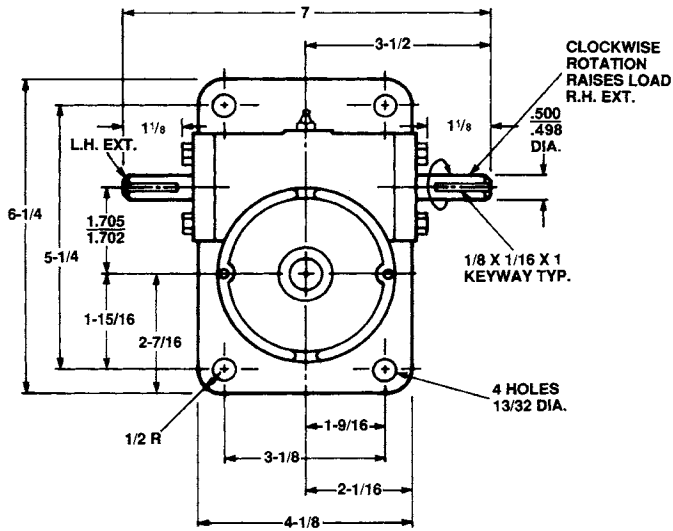

1" Diameter x 1.000 Lead Lifting Screws

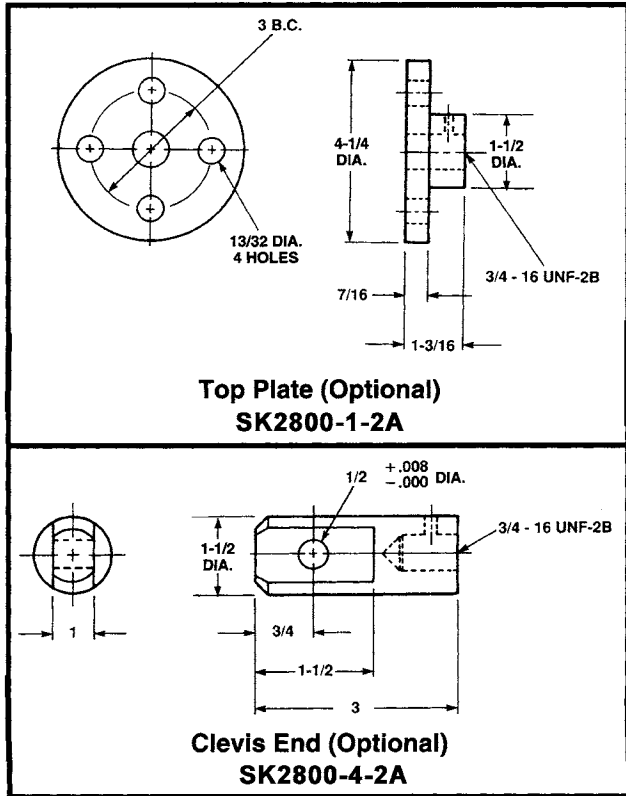

Note: Lifting screw is not keyed. Top should be secured to a lifting member to prevent rotation. When a Bellows Boot is required, see pages 146-147. Dimensions are subject to change without notice.

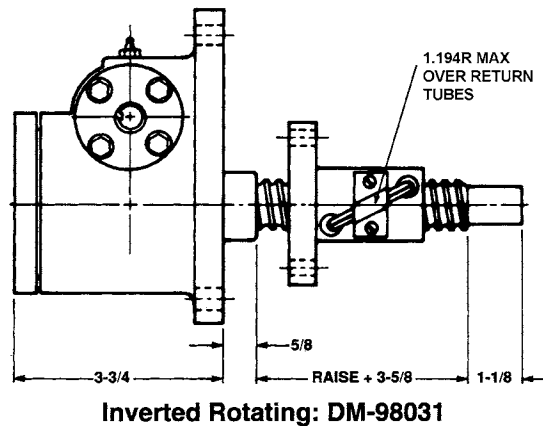
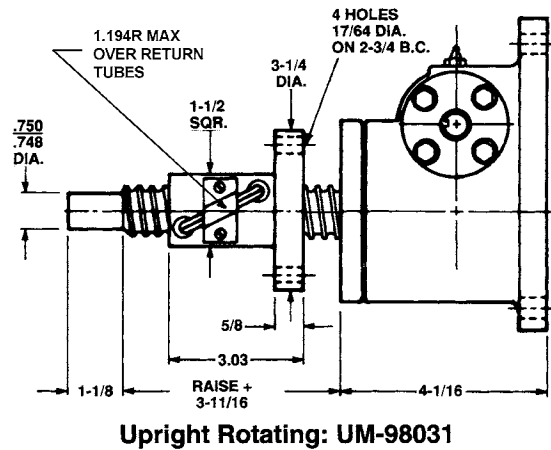
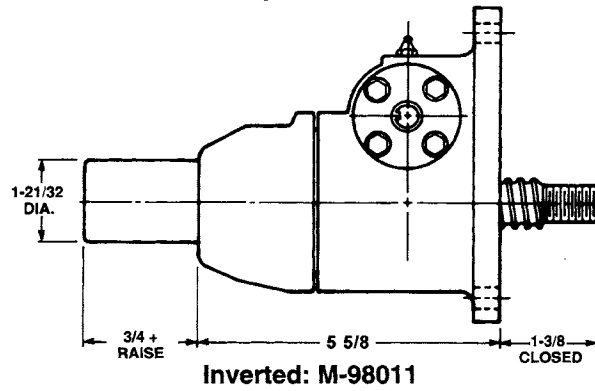
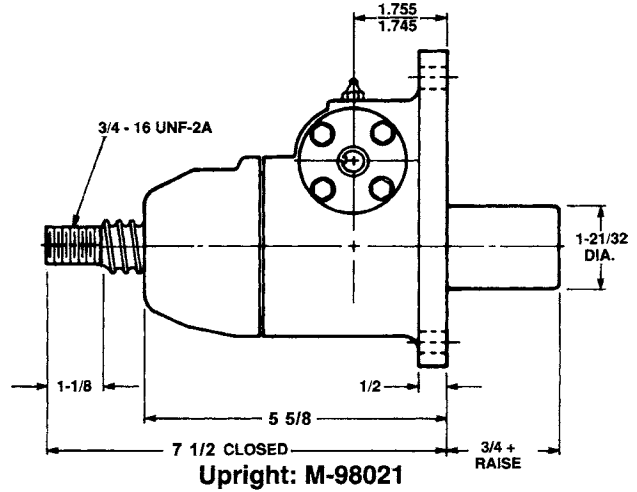

2 Ton Capacity, 9800 Series

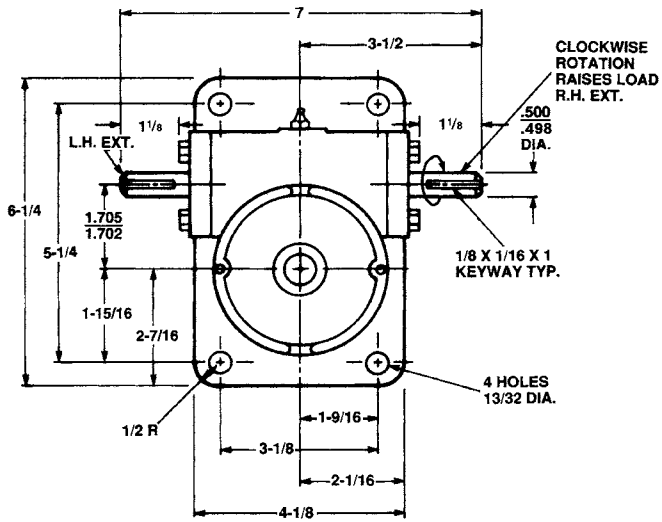

1" Diameter x .250 Lead Lifting Screws

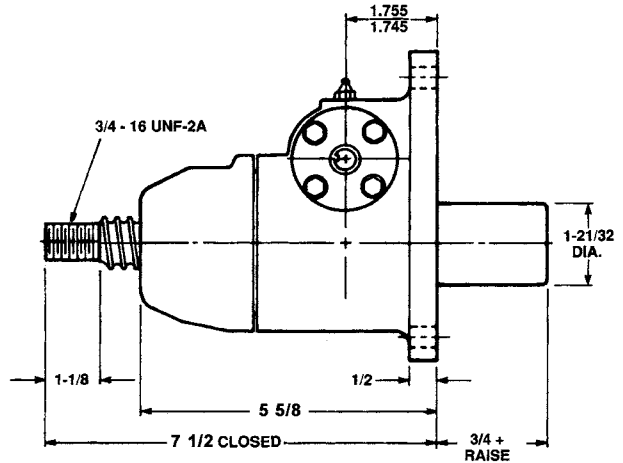

Upright: M-9802

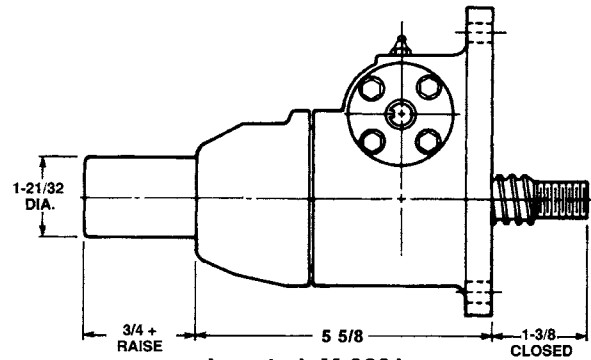

Inverted: M-9801

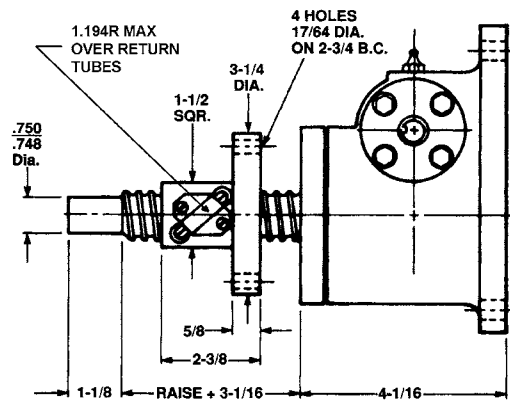

Upright Rotating: UM-9803

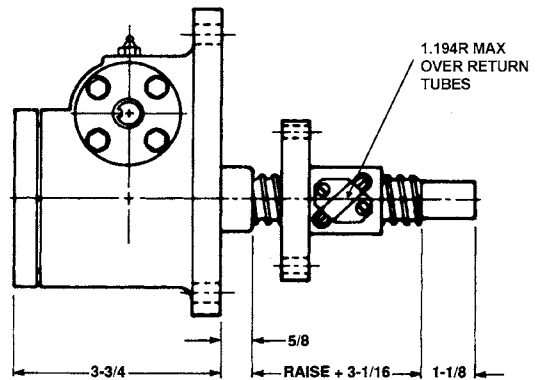

Inverted Rotating: DM-9803

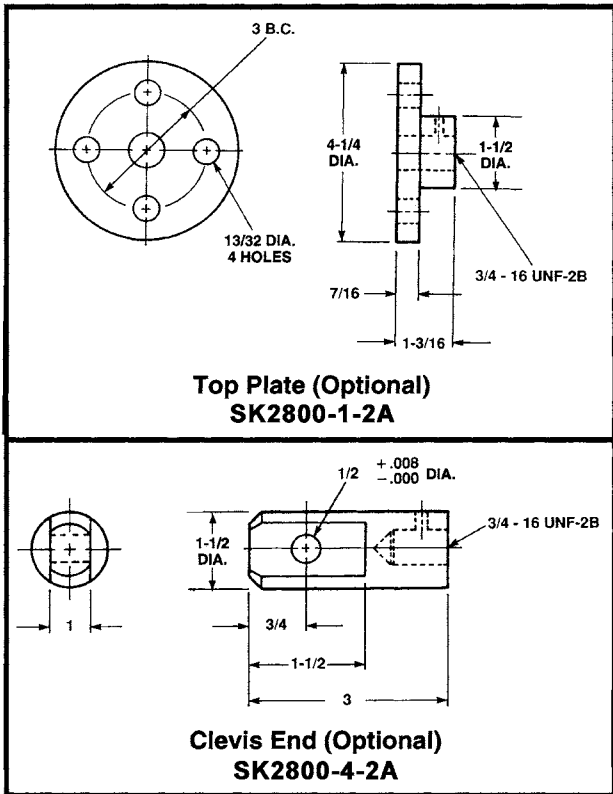

Top Plate (Optional)
SK2800-1-2A

Clevis End (Optional)
SK2800-4-2A

Note: Lifting screw is not keyed. Top should be secured to a lifting member to prevent rotation. When a Bellows Boot is required, see pages 146-147. Dimensions are subject to change without notice.

BALL SCREW ACTUATORS

2 Ton Capacity - 1" Lead, 7800 Series

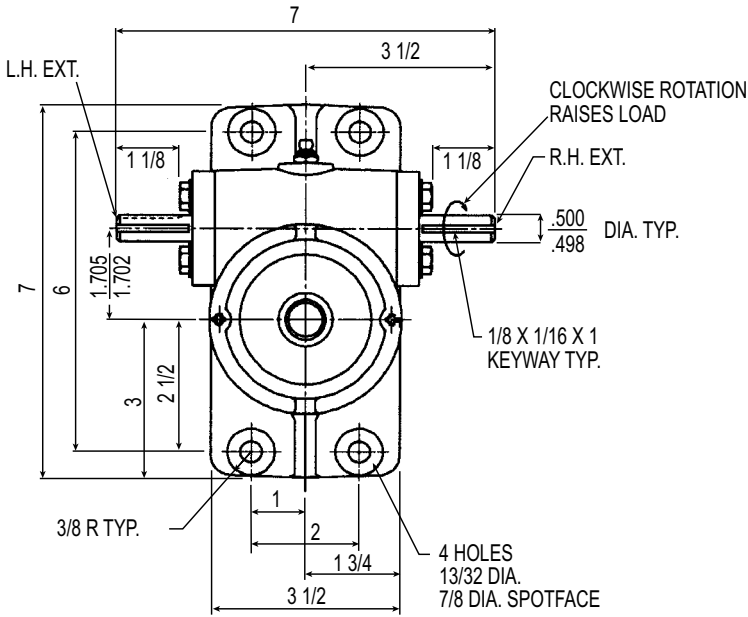

Top View: M-78021
1" Diameter x 1.000 Lead Lifting Screws

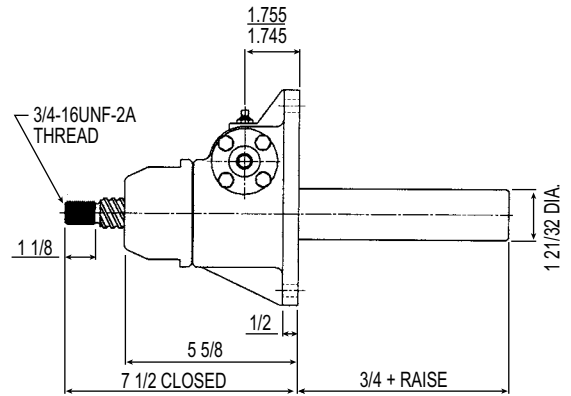

Upright: M-78021

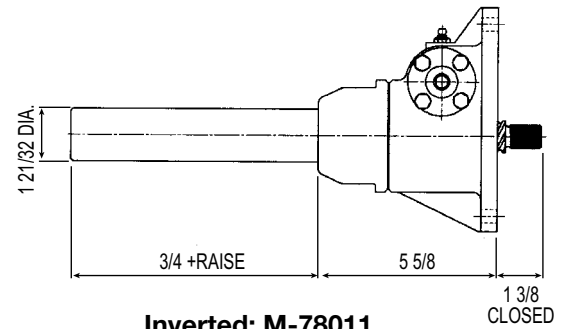

Inverted: M-78011

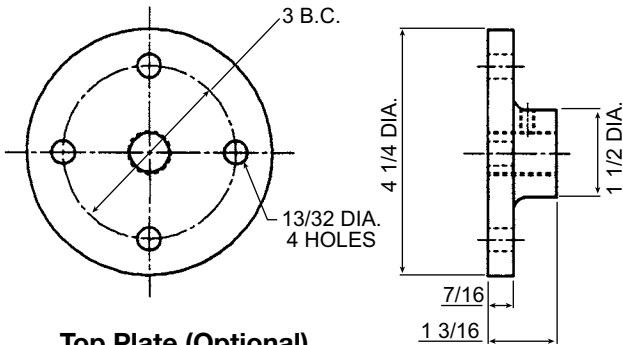

Top Plate (Optional)
SK2800-1-2A

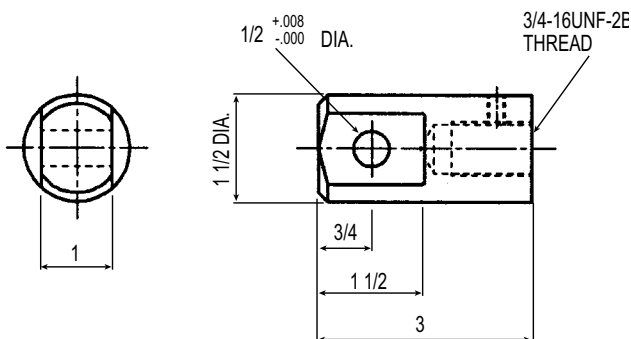

Clevis End (Optional)
SK2800-4-2A

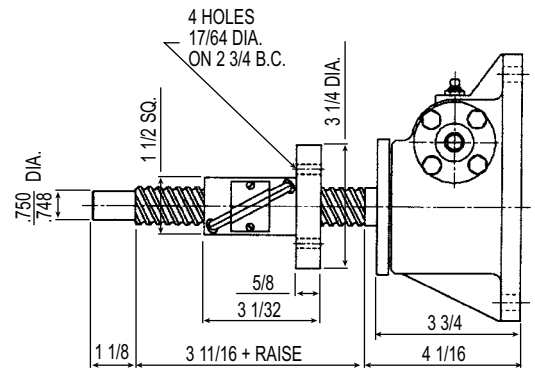

Upright Rotating: UM-78031

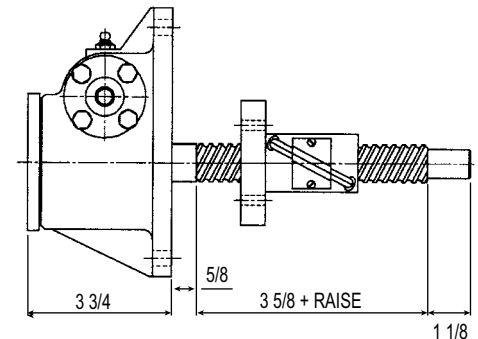

Inverted Rotating: DM-78031

Note: Lifting screw is not keyed. Top should be secured to a lifting member to prevent rotation. When a Bellows Boot is required, see pages 146-147. Dimensions are subject to change without notice.

2 Ton Capacity, 7800 Series

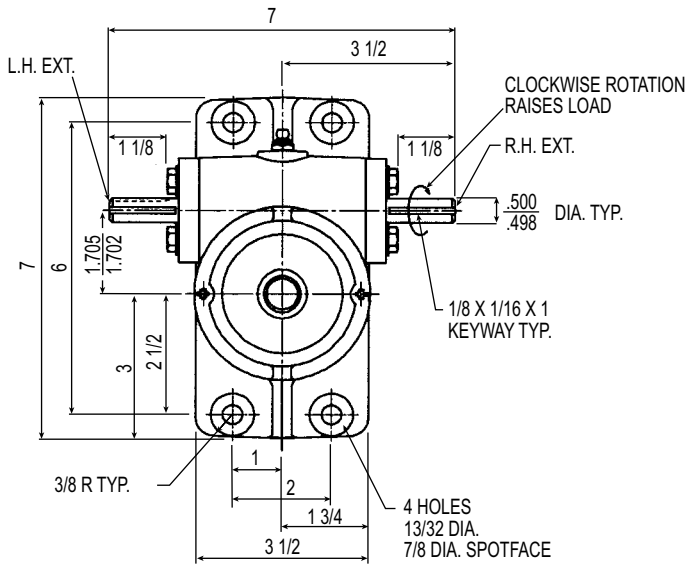

Top View: M-7802
1" Diameter x .250 Lead Lifting Screws

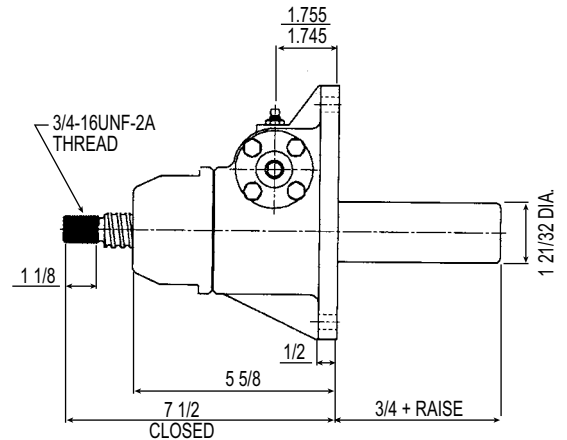

Upright: M-7802

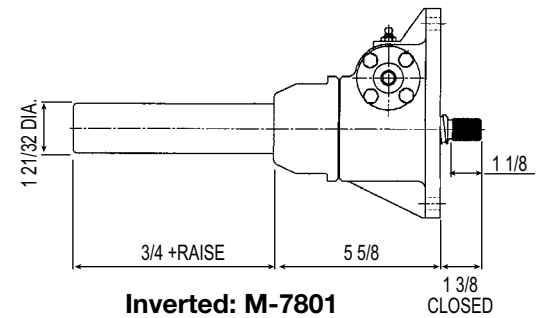

Inverted: M-7801

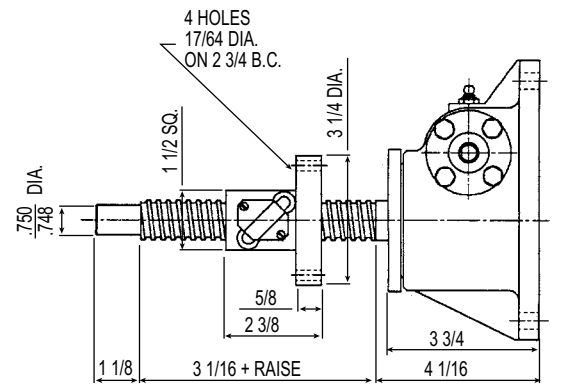
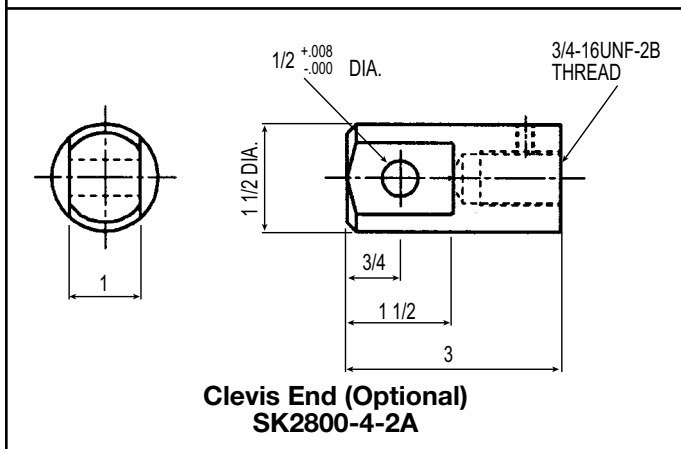
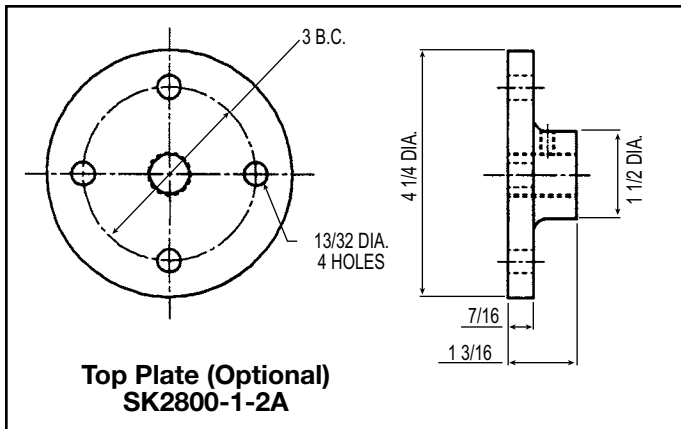

Upright Rotating: UM-7803

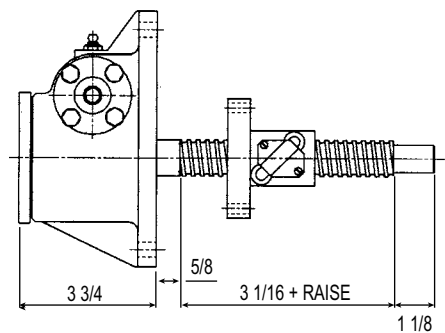

Inverted Rotating: DM-7803

Note: Lifting screw is not keyed. Top should be secured to a lifting member to prevent rotation. When a Bellows Boot is required, see pages 146-147. Dimensions are subject to change without notice.

BALL SCREW ACTUATORS

2 Ton Capacity - 1" Lead, 2800 Series

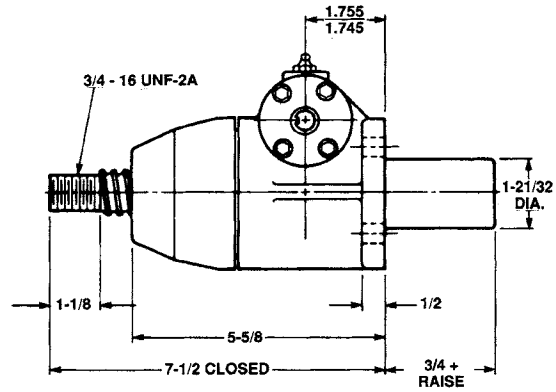
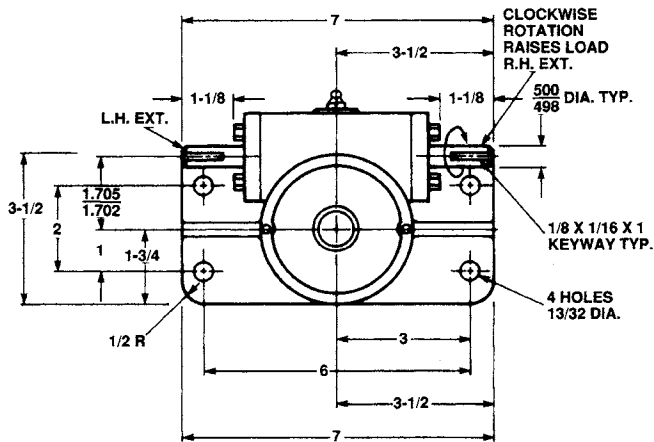

Upright: M-28021

1" Diameter x 1.000 Lead Lifting Screws

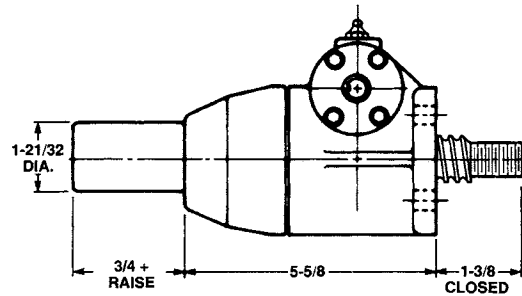
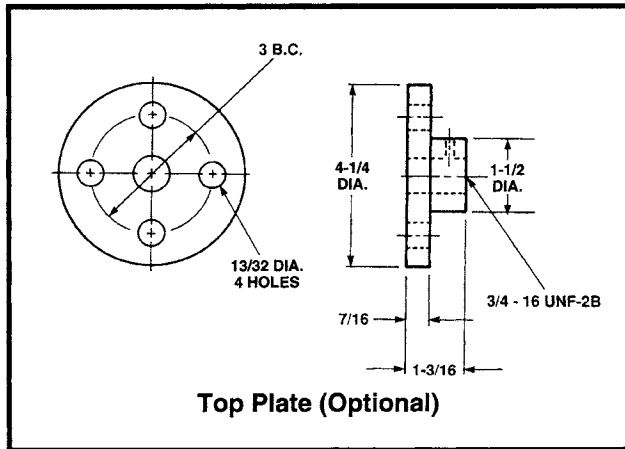

Inverted: M-28011

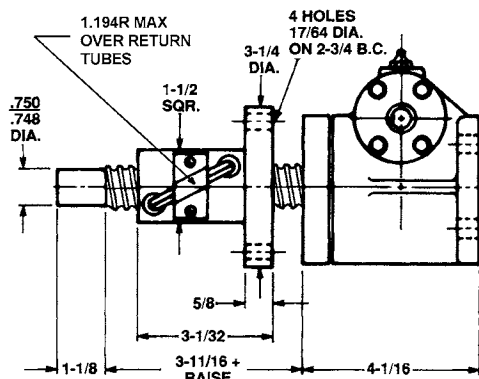
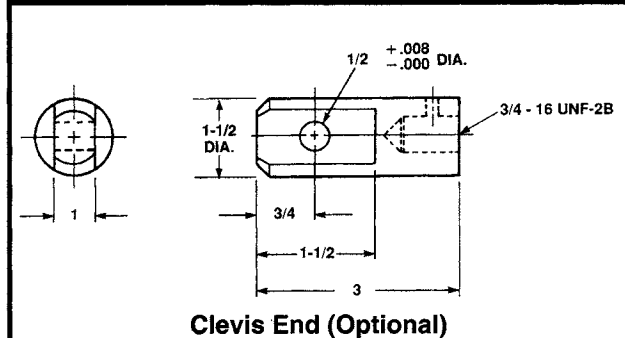

Upright Rotating: KUM-28031

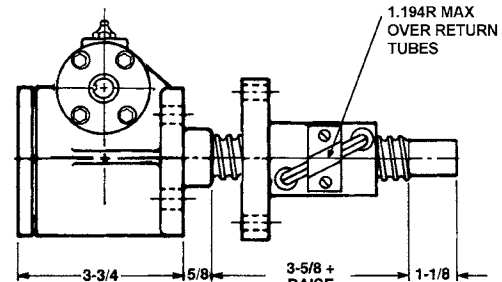
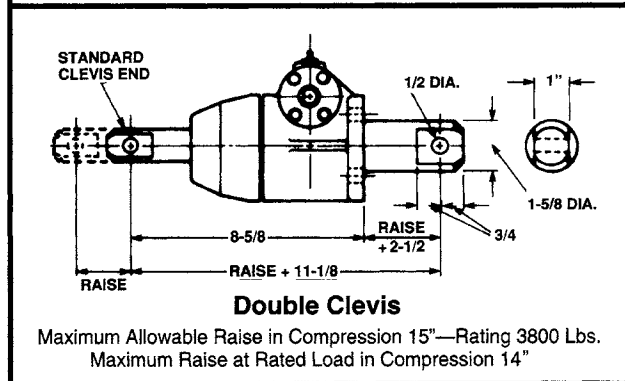

Inverted Rotating: KDM-28031

Note: Lifting screw is not keyed. Top should be secured to a lifting member to prevent rotation. When a Bellows Boot is required, see pages 146-147. Dimensions are subject to change without notice.

2 Ton Capacity, 2800 Series

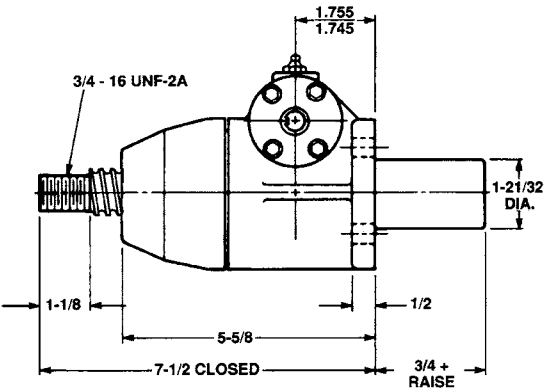
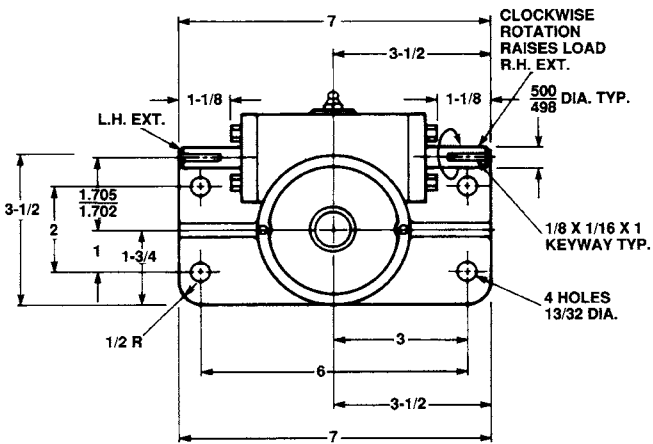

Upright: M-2802

1" Diameter x .250 Lead Lifting Screws

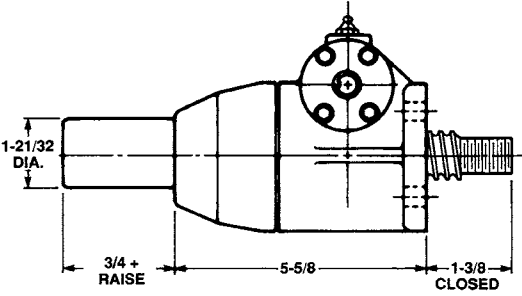

Inverted: M-2801

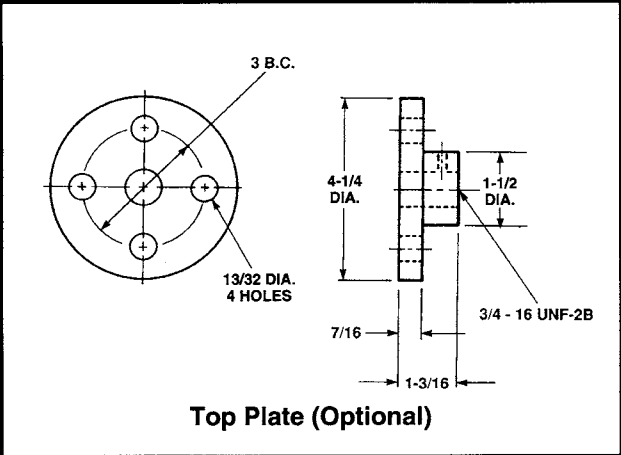

Top Plate (Optional)

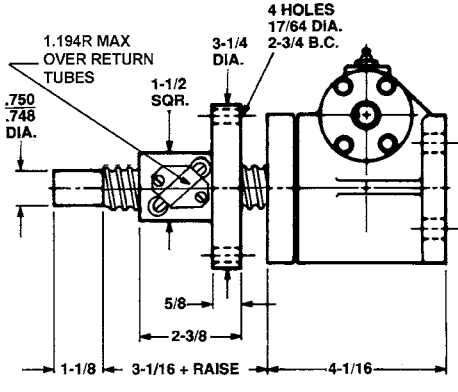

Upright Rotating: KUM-2803

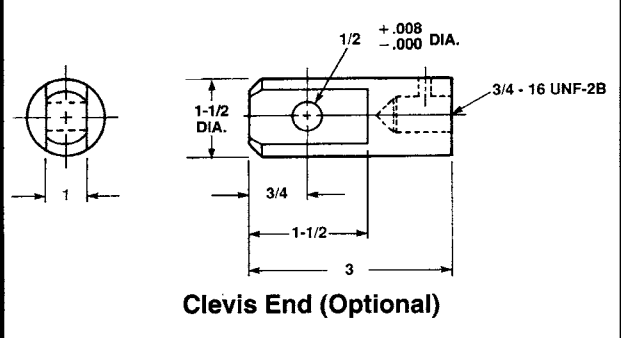

Clevis End (Optional)

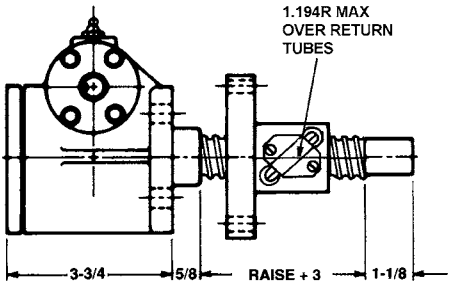

Inverted Rotating: KDM-2803

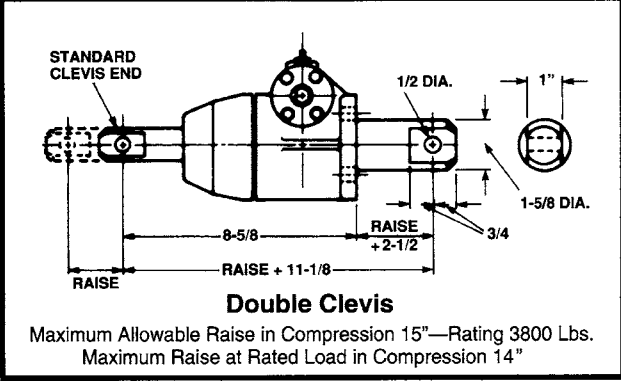

Double Clevis

Maximum Allowable Raise in Compression 15"—Rating 3800 Lbs.
Maximum Raise at Rated Load in Compression 14"

Note: Lifting screw is not keyed. Top should be secured to a lifting member to prevent rotation. When a Bellows Boot is required, see pages 146-147. Dimensions are subject to change without notice.

BALL SCREW ACTUATORS

3 Ton Capacity, 9800 Series

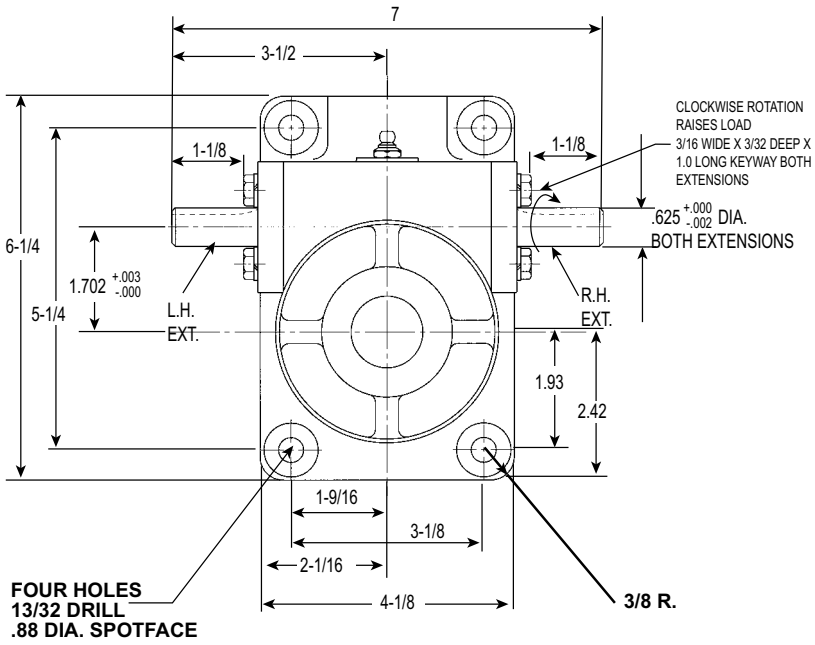

1-11/64" Diameter x .413 Lead Lifting Screw

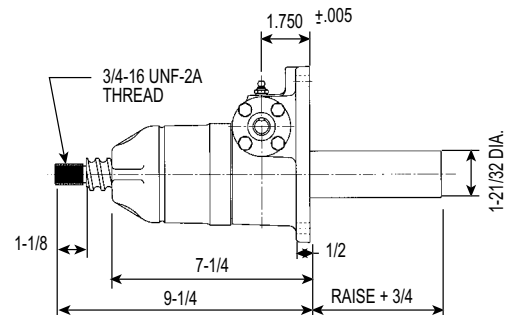

Upright: M-98003

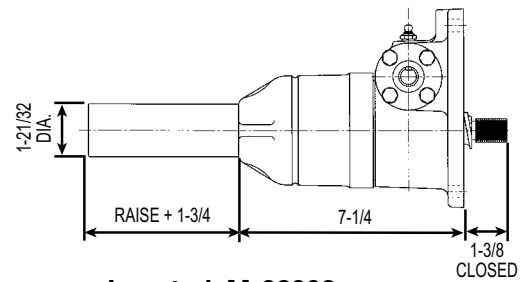

Inverted: M-98002

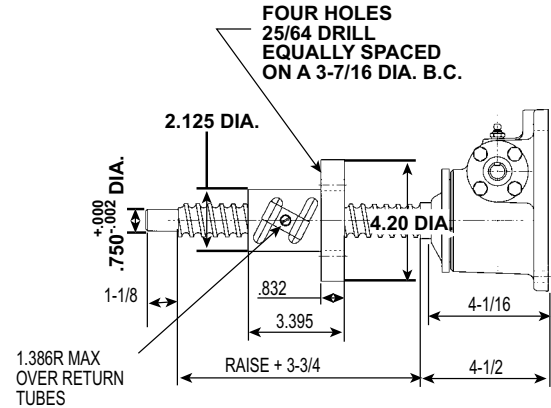
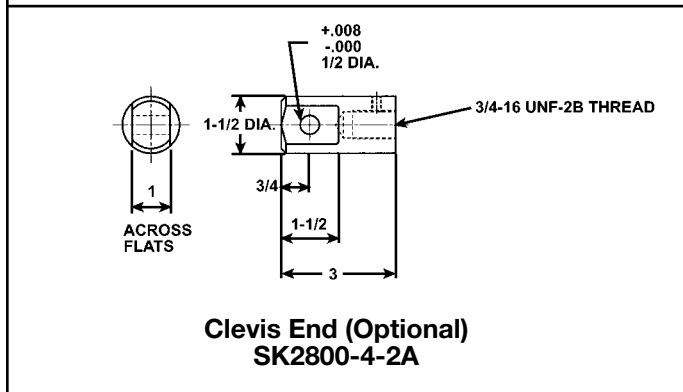
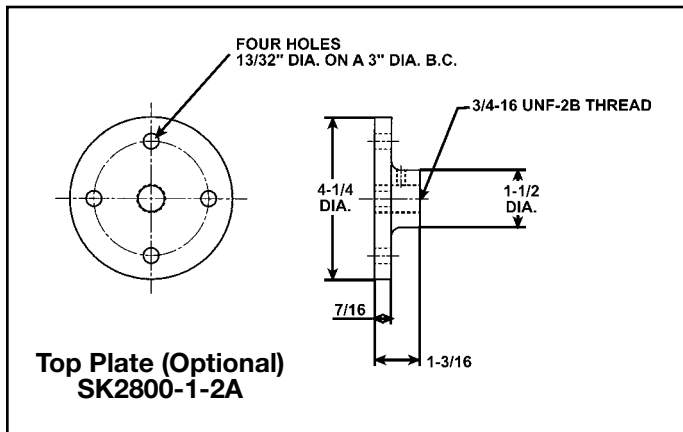

Upright Rotating: UM-98004

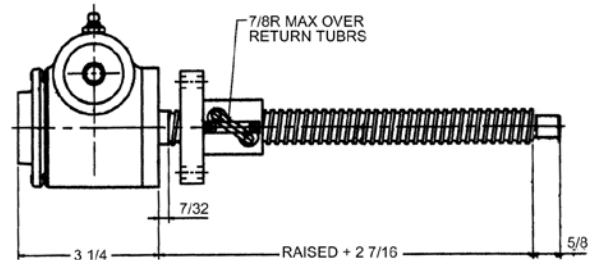

Inverted Rotating: DM-98004

Note: Lifting screw is not keyed. Top should be secured to a lifting member to prevent rotation. When a Bellows Boot is required, see pages 146-147. Dimensions are subject to change without notice.

3 Ton Capacity, 2800 Series

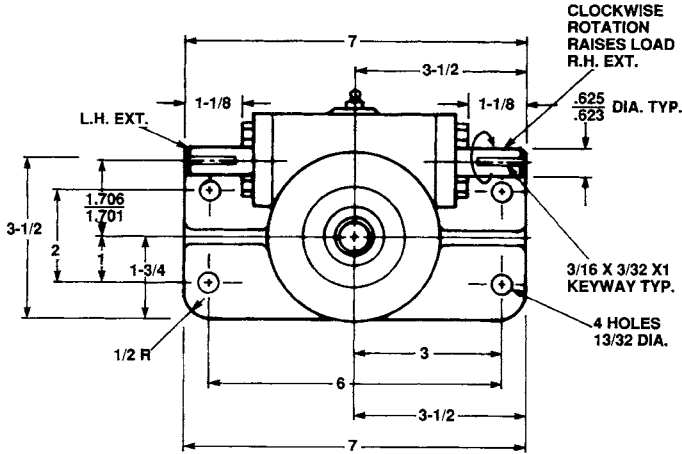

1 1/64" Diameter x .413 Lead Lifting Screws

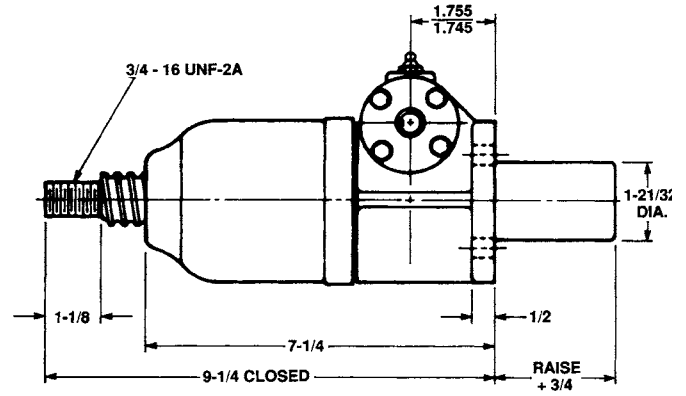

Upright: M-28003

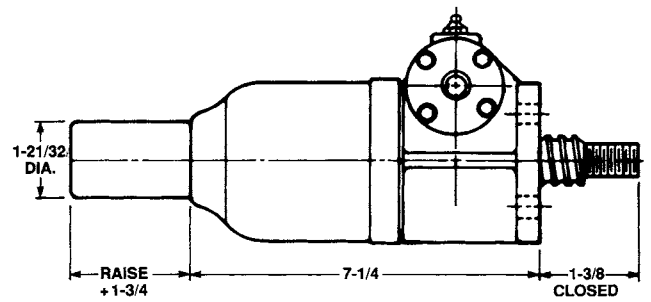

Inverted: M-28002

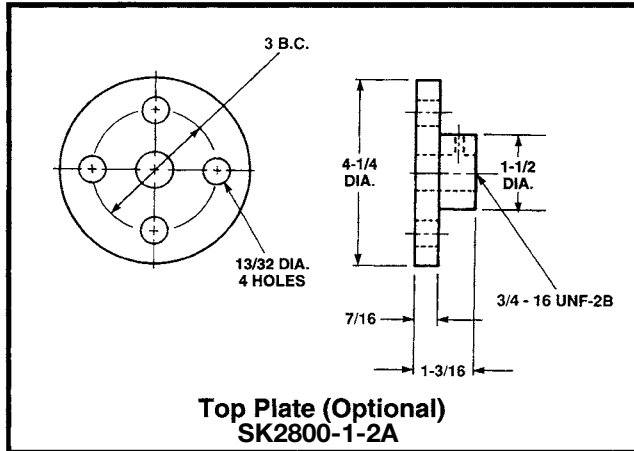

Top Plate (Optional)
SK2800-1-2A

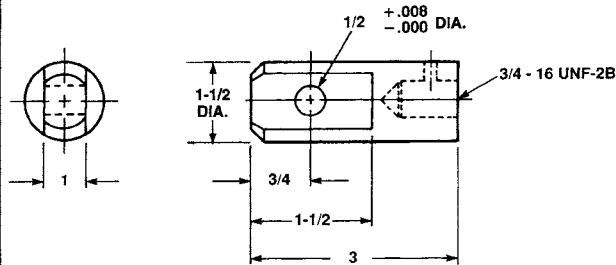

Clevis End (Optional)
SK2800-4-2A

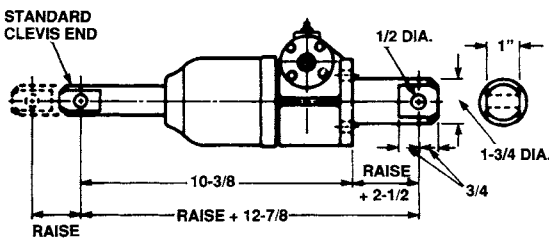

Double Clevis

Maximum Allowable Raise in Compression 15" —Rating 4200 Lbs.
Maximum Raise at Rated Load in Compression 13".

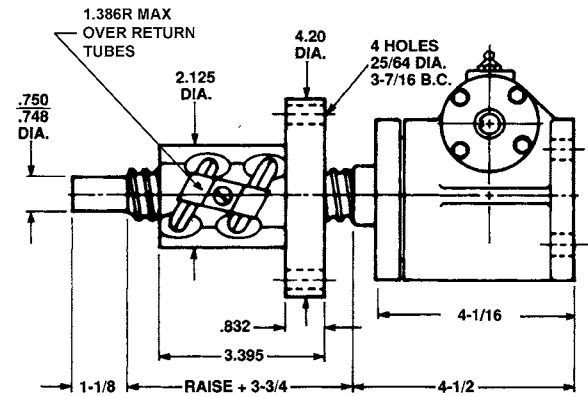

Upright Rotating: KUM-28004

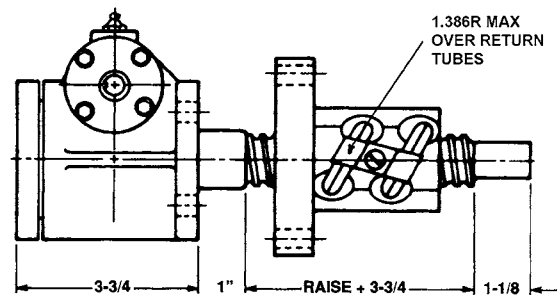

Inverted Rotating: KDM-28004

Note: Lifting screw is not keyed. Top should be secured to a lifting member to prevent rotation. When a Bellows Boot is required, see pages 146-147. Dimensions are subject to change without notice.

BALL SCREW ACTUATORS

5 Ton Capacity - 1" Lead

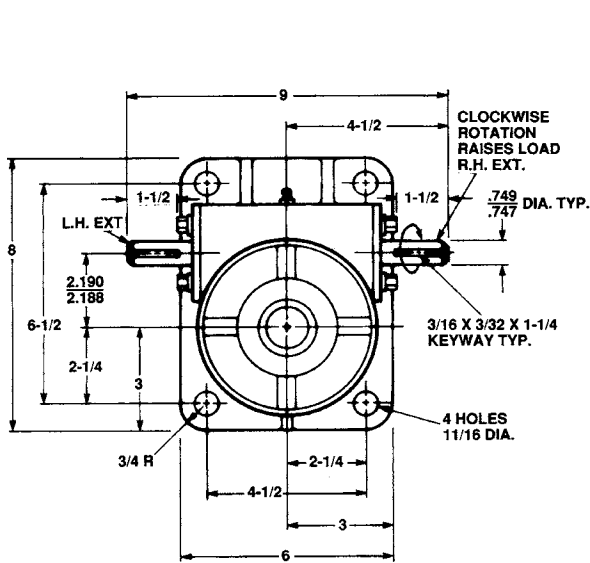

1 1/2" Diameter x 1.000 Lead Lifting Screws

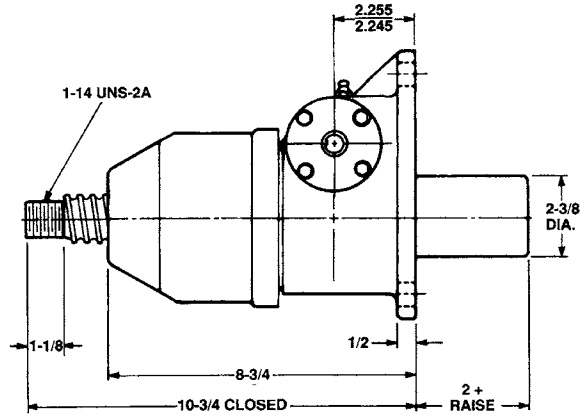
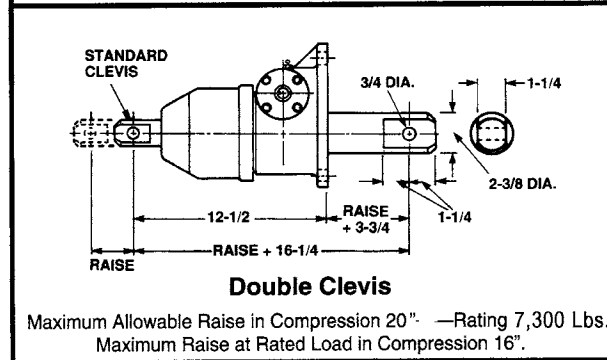
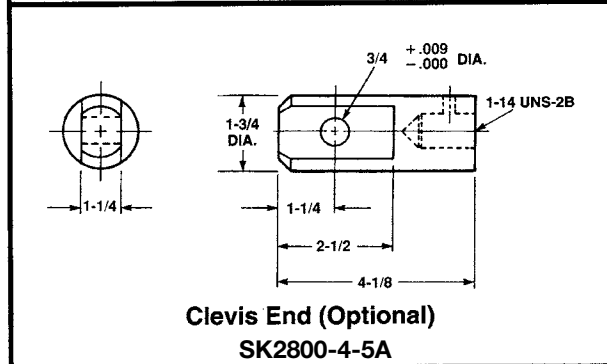
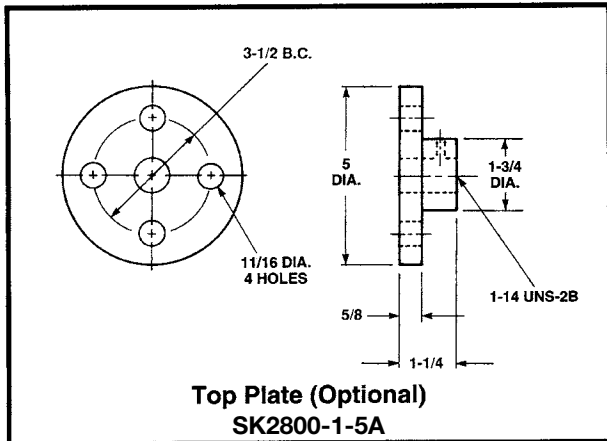

Upright: M-98051

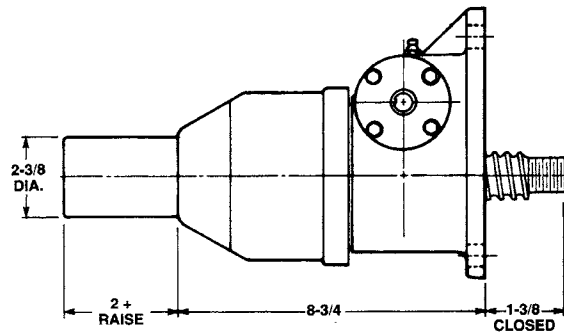

Inverted: M-98041

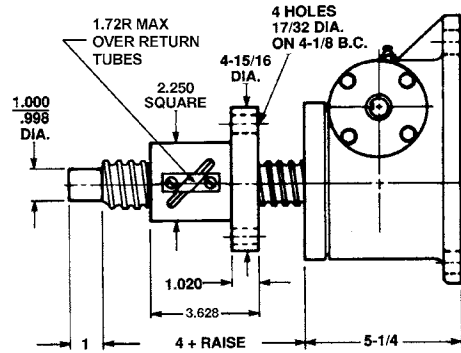

Upright Rotating: UM-98061

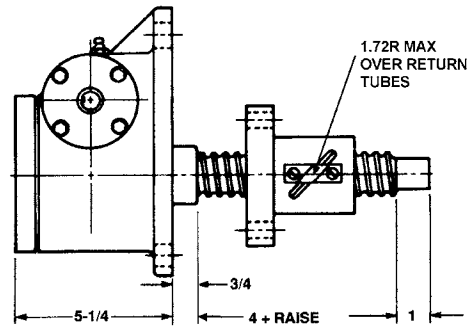

Inverted Rotating: DM-98061

Note: Lifting screw is not keyed. Top should be secured to a lifting member to prevent rotation. When a Bellows Boot is required, see pages 146-147. Dimensions are subject to change without notice.

5 Ton Capacity

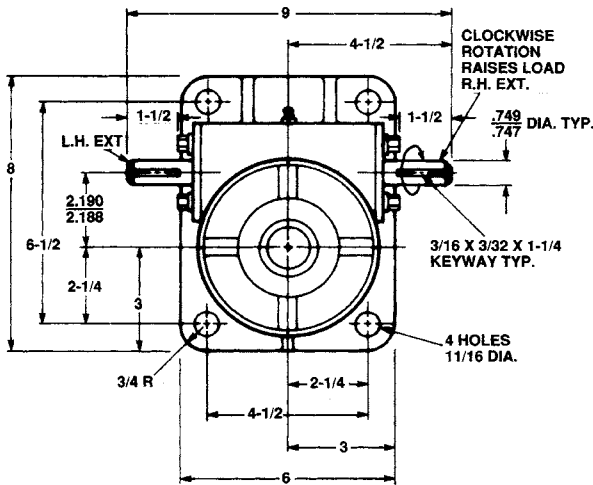

1 1/2" Diameter x .474 Lead Lifting Screws

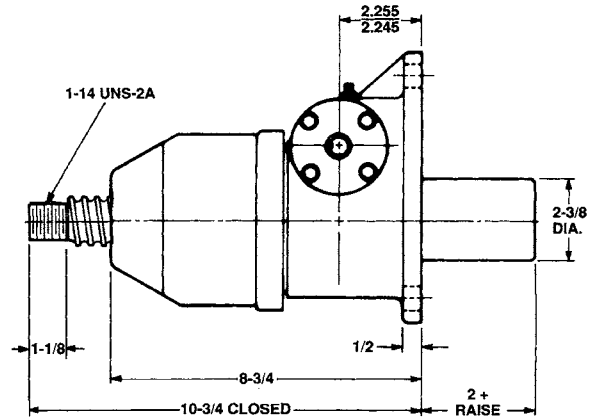

Upright: M-9805

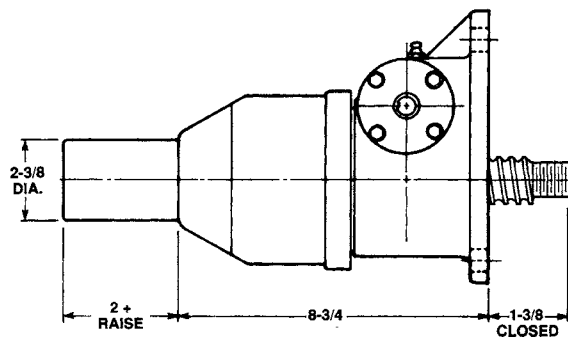

Inverted: M-9804

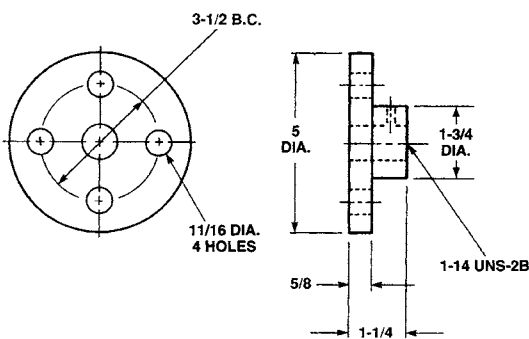

Top Plate (Optional)
SK2800-1-5A

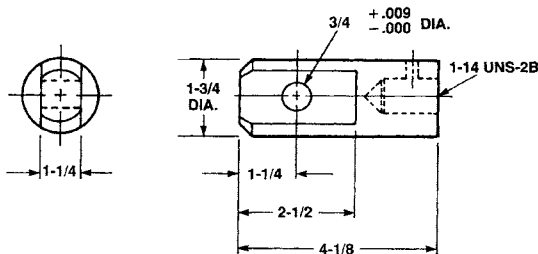

Clevis End (Optional)
SK2800-2-5A

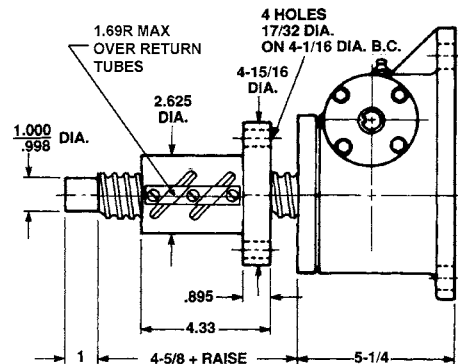

Upright Rotating: UM-9806

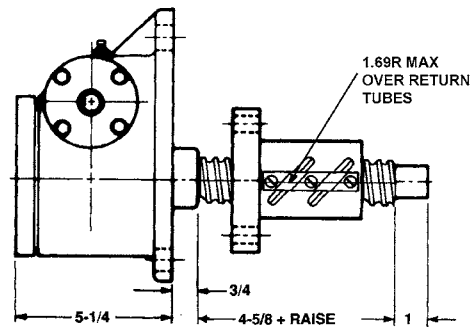

Inverted Rotating: DM-9806

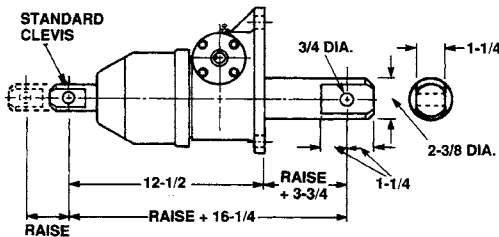

Double Clevis

Maximum Allowable Raise in Compression 20" —Rating 7,300 Lbs.
Maximum Raise at Rated Load in Compression 16".

Note: Lifting screw is not keyed. Top should be secured to a lifting member to prevent rotation. When a Bellows Boot is required, see pages 146-147. Dimensions are subject to change without notice.

BALL SCREW ACTUATORS

10 Ton Capacity - 1" Lead

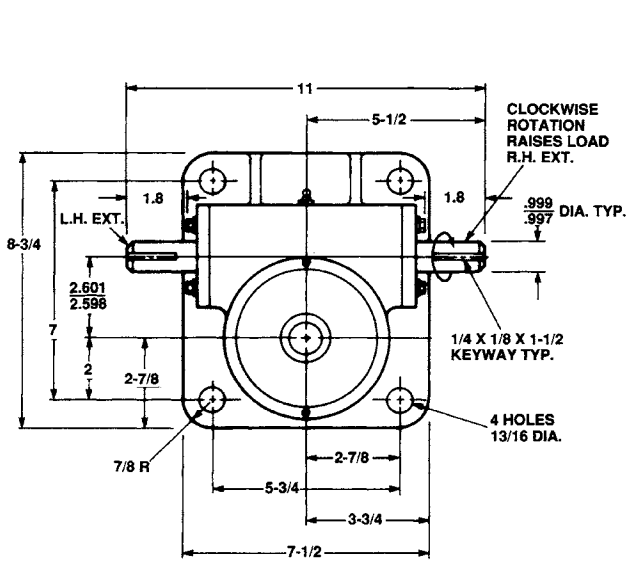

1 1/2" Diameter x 1.000 Lead Lifting Screws

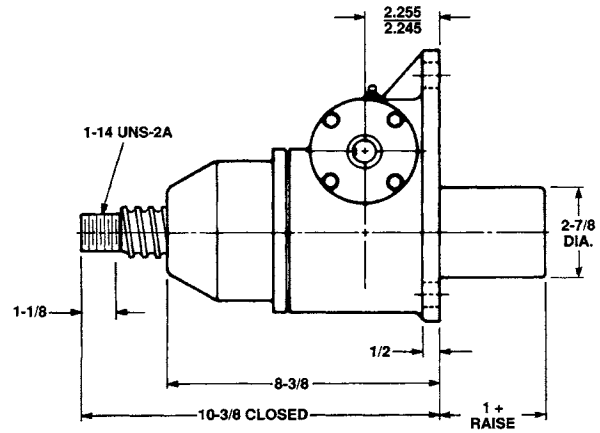

Upright: M-98101

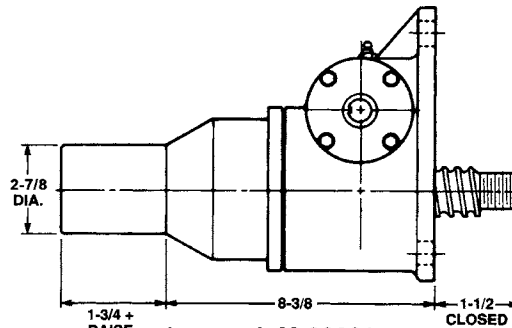

Inverted: M-98091

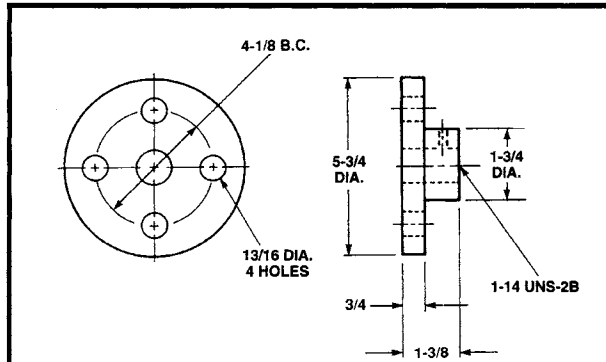

Top Plate (Optional)
SK2800-1-10A

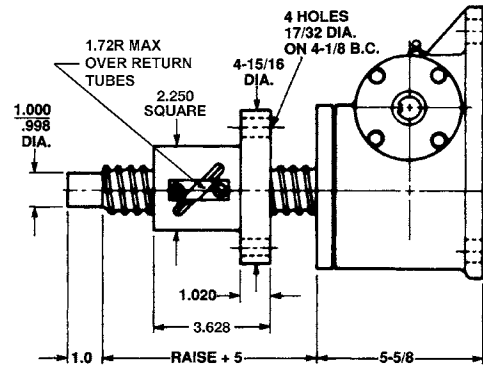

Upright Rotating: UM-98111

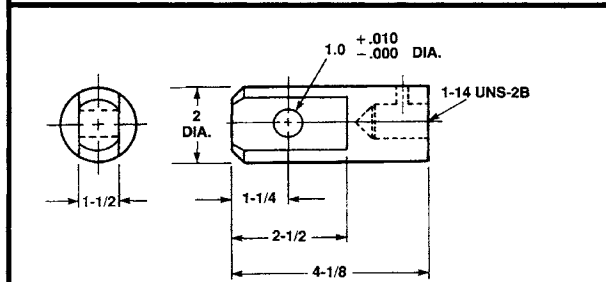

Clevis End (Optional)
SK2800-4-10A

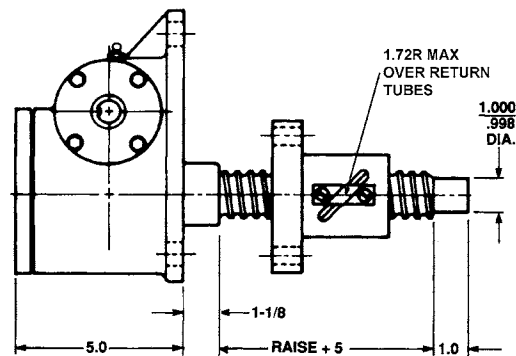

Inverted Rotating: DM-98111

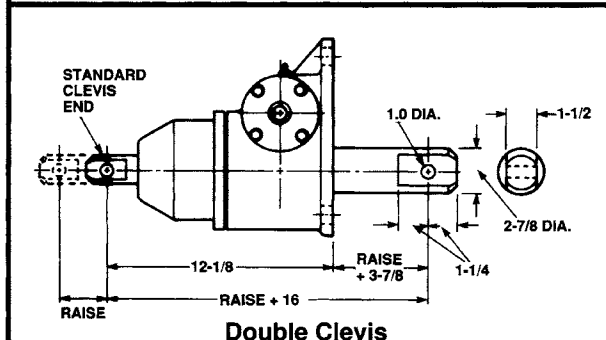

Double Clevis

Maximum Allowable Raise in Compression 20" — Rating 7,300 Lbs.
Maximum Raise at Rated Load in Compression 9".

Note: Lifting screw is not keyed. Top should be secured to a lifting member to prevent rotation. When a Bellows Boot is required, see pages 146-147. Dimensions are subject to change without notice.

10 Ton Capacity

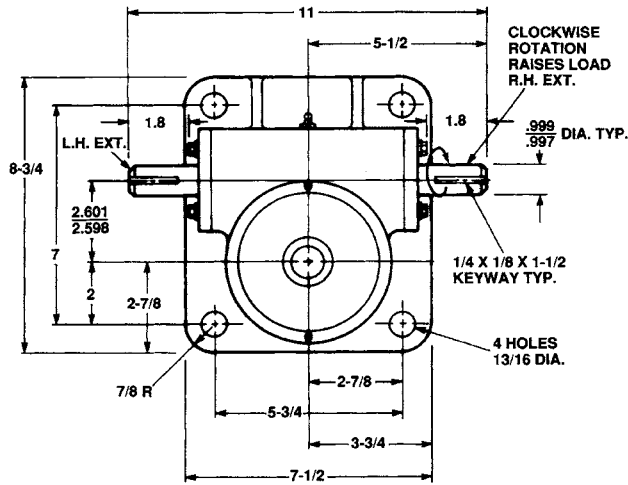

1 1/2" Diameter x .474 Lead Lifting Screws

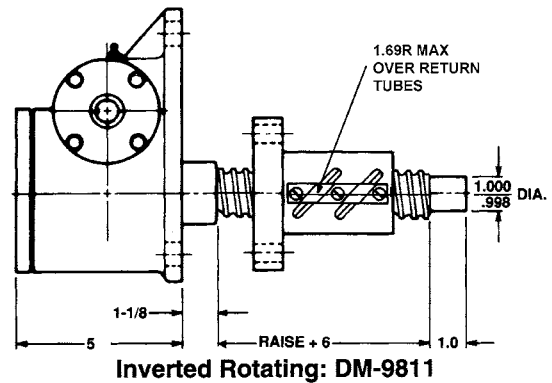
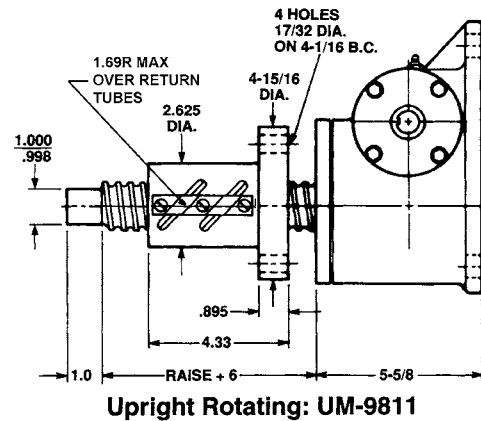
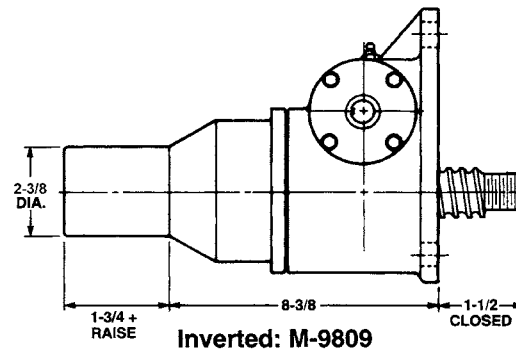
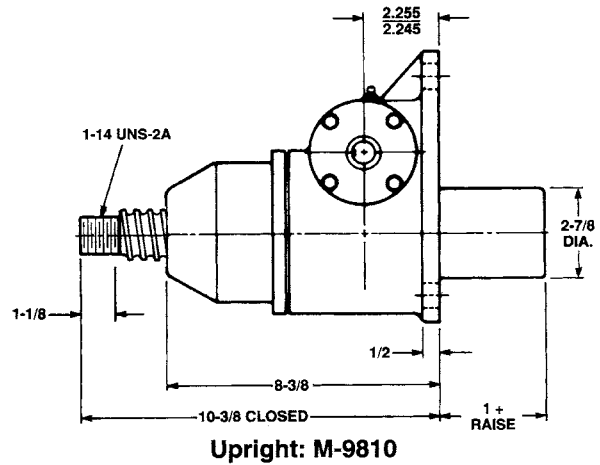
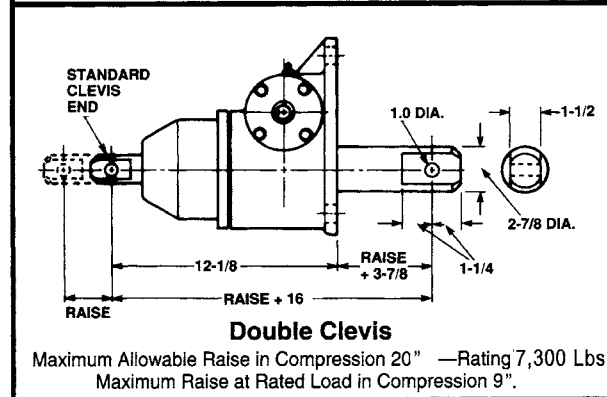
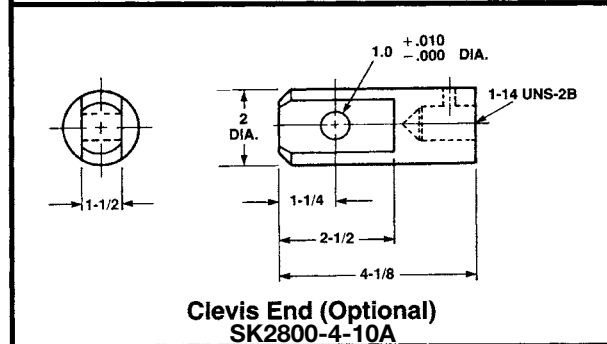
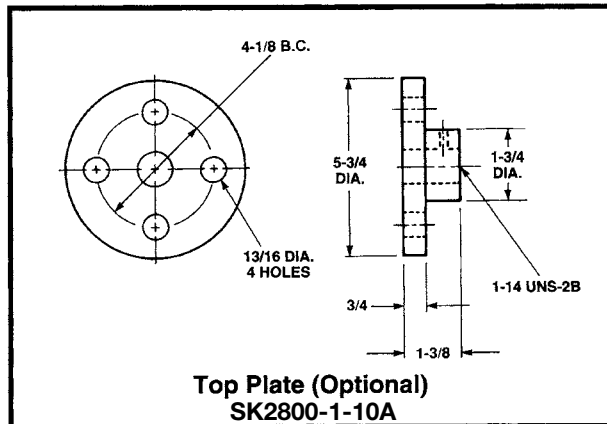

Note: Lifting screw is not keyed. Top should be secured to a lifting member to prevent rotation. When a Bellows Boot is required, see pages 146-147. Dimensions are subject to change without notice.

BALL SCREW ACTUATORS

20 Ton Capacity Standard and 1" Lead

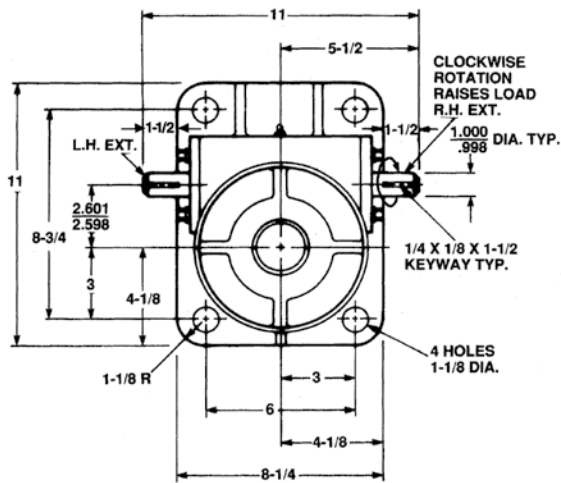

2 1/4" Diameter x .500 Lead Lifting Screws
2 1/4" Diameter x 1.00 Lead Lifting Screws

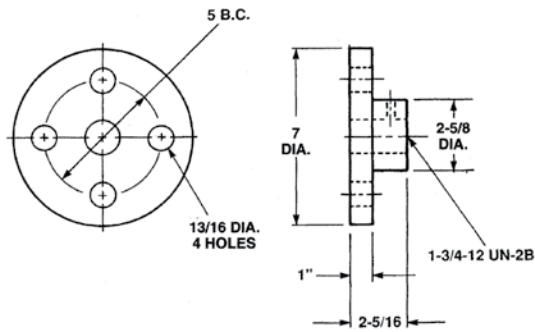

Top Plate (Optional)
SK2800-1-20A

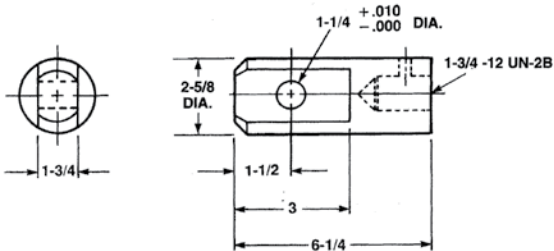

Clevis End (Optional)
SK2800-4-20A

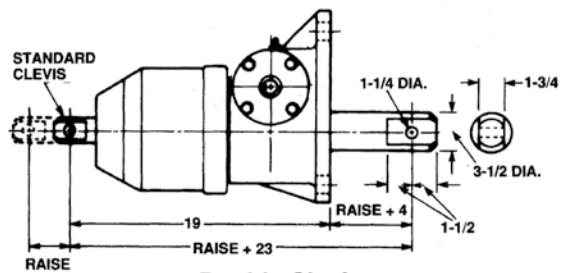

Double Clevis

Maximum Allowable Raise in Compression 35° - Rating 19,000 Lbs.
Maximum Raise at Rated Load in Compression 30°.

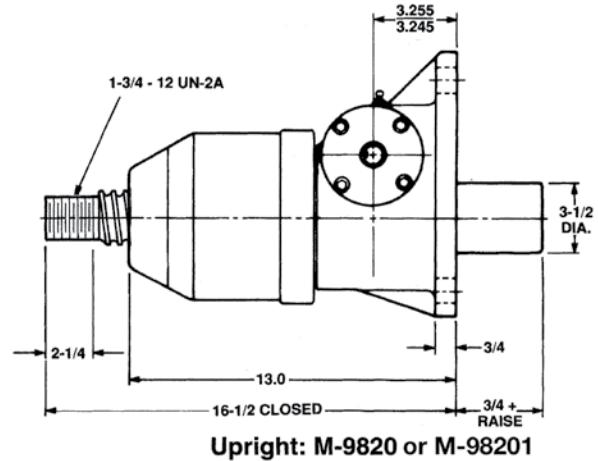

Upright: M-9820 or M-98201

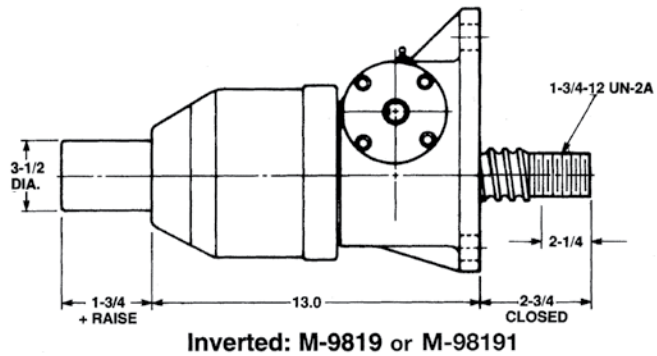

Inverted: M-9819 or M-98191

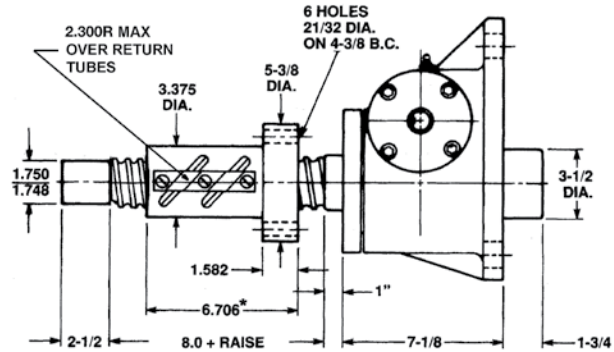

Upright Rotating: AUM-9821 or AUM-98211

*1" Lead Ball nut O.A. Length 6.379

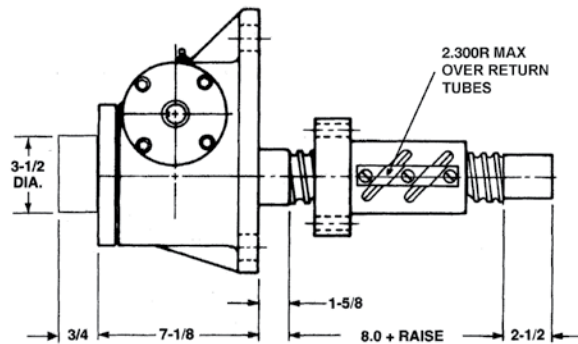

Inverted Rotating: ADM-9821 or ADM-98211

Note: Lifting screw is not keyed. Top should be secured to a lifting member to prevent rotation. When a Bellows Boot is required, see pages 146-147. Dimensions are subject to change without notice.

25 Ton Capacity

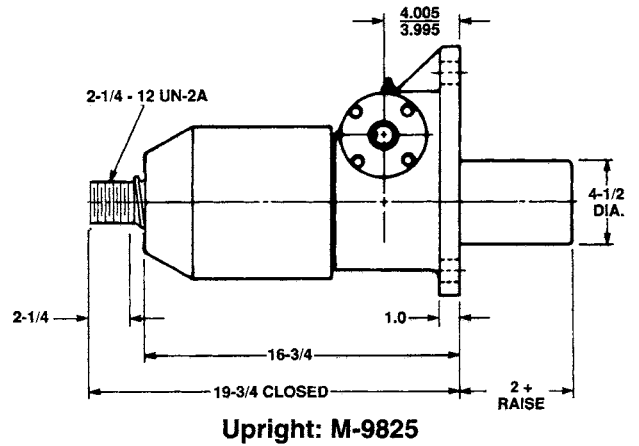
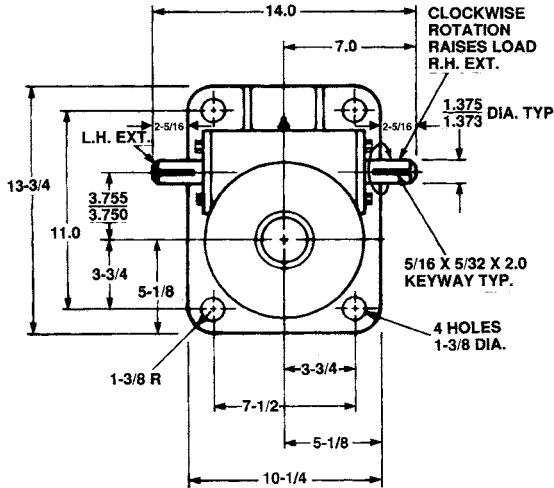

3" Diameter x .660 Lead Lifting Screws

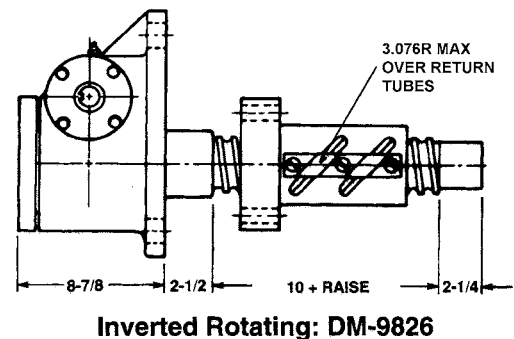
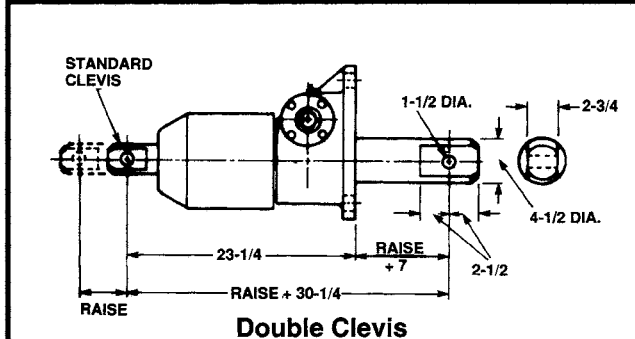
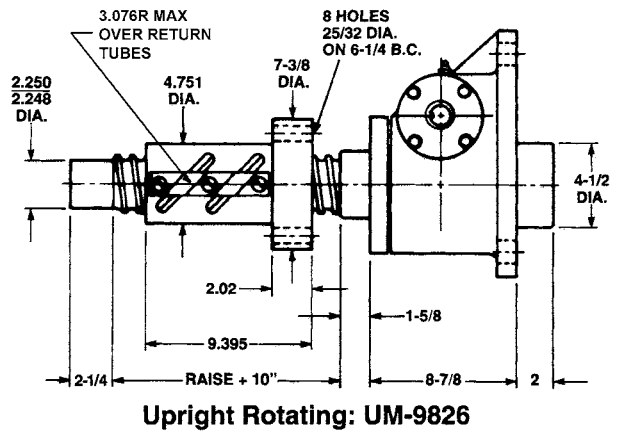
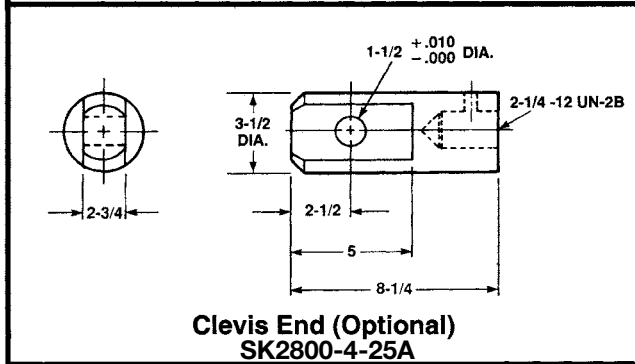
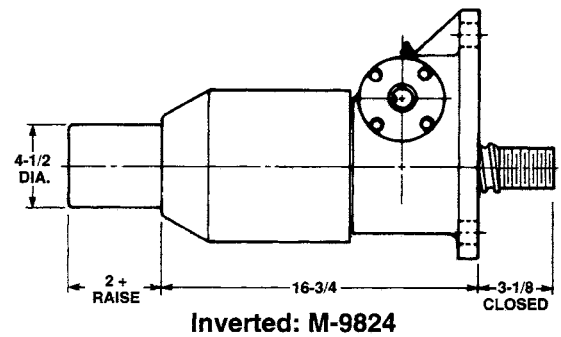
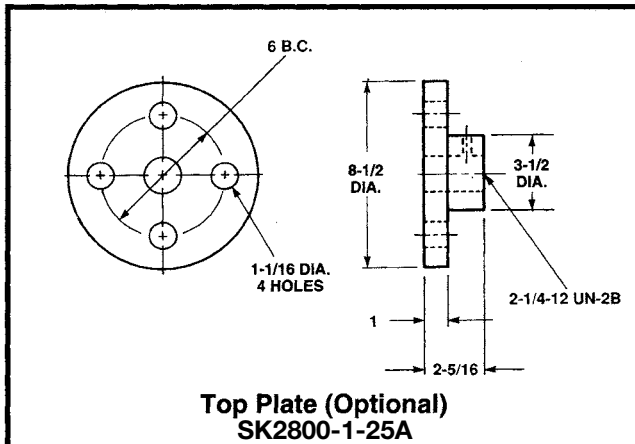

Maximum Allowable Raise in Compression 47"—Rating 35,000 Lbs.
Maximum Raise at Rated Load in Compression 36"

Note: Lifting screw is not keyed. Top should be secured to a lifting member to prevent rotation. When a Bellows Boot is required, see pages 146-147. Dimensions are subject to change without notice.

BALL SCREW ACTUATORS

50 Ton Capacity, 9800 Series

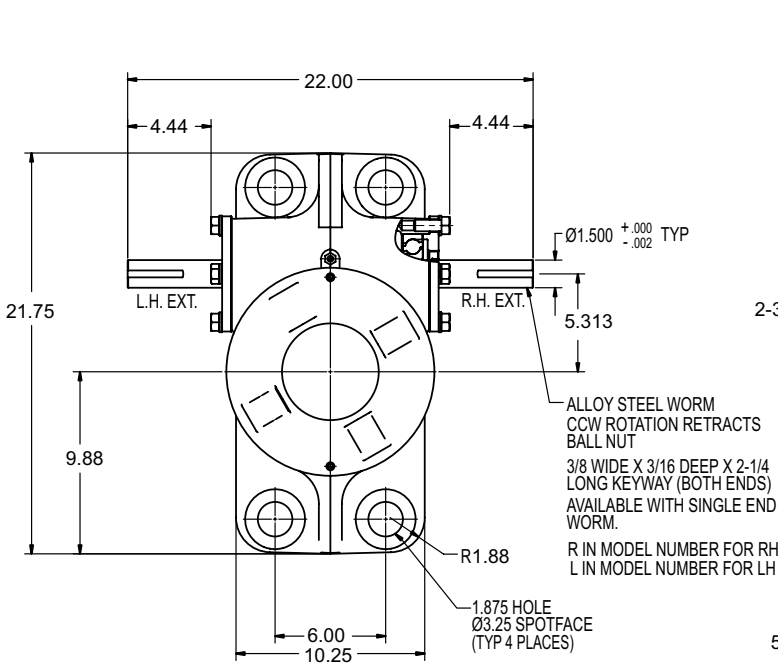

4" Diameter x 1.000 Lead Lifting Screw

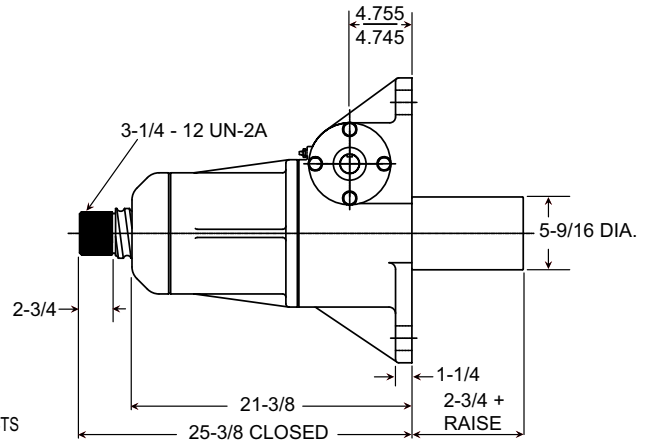
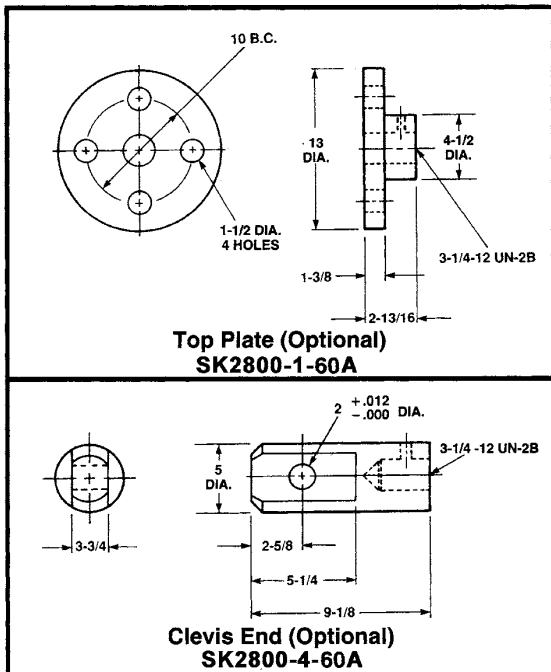

Upright: M-9860

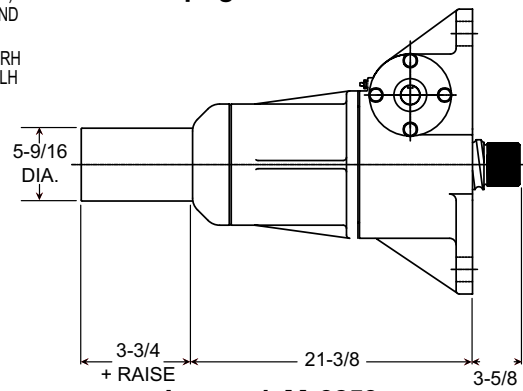

Inverted: M-9859

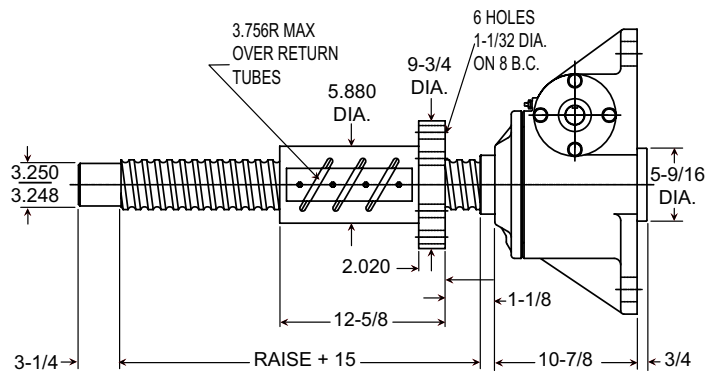

Upright Rotating: UM-9861

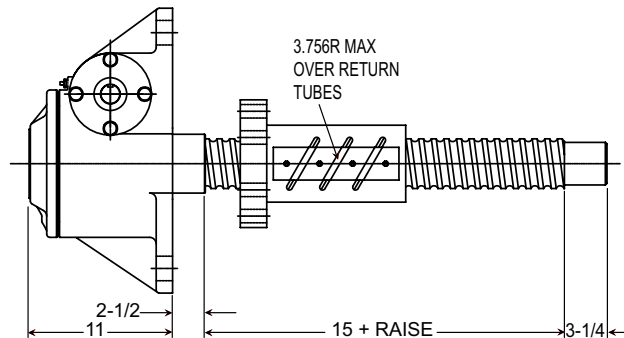

Inverted Rotating: DM-9861

Note: Lifting screw is not keyed. Top should be secured to a lifting member to prevent rotation. When a Bellows Boot is required, see pages 146-147. Dimensions are subject to change without notice.

50 Ton Capacity, 2800 Series

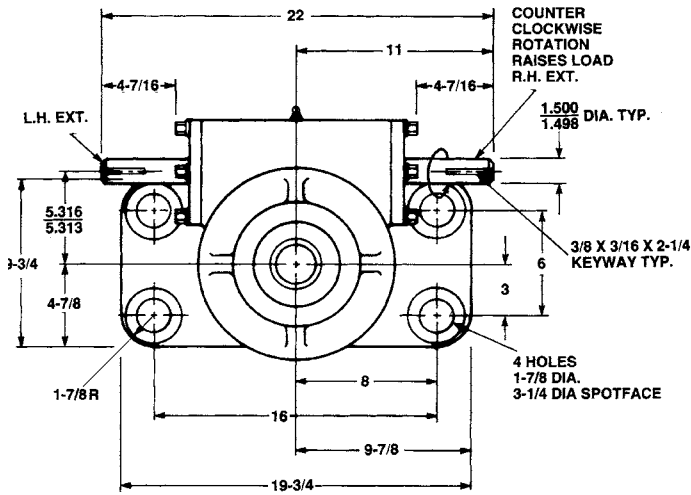

4" Diameter x 1.000 Lead Lifting Screws

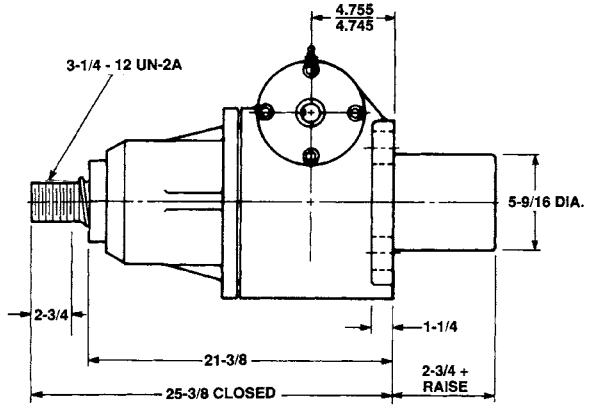

Upright: M-2860

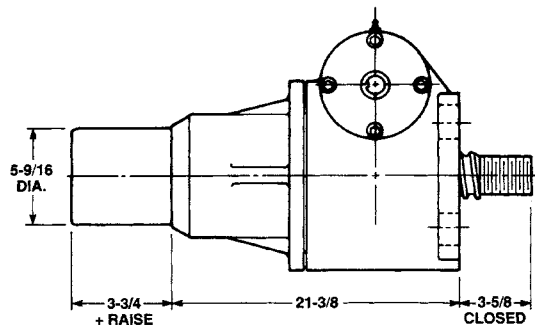

Inverted: M-2859

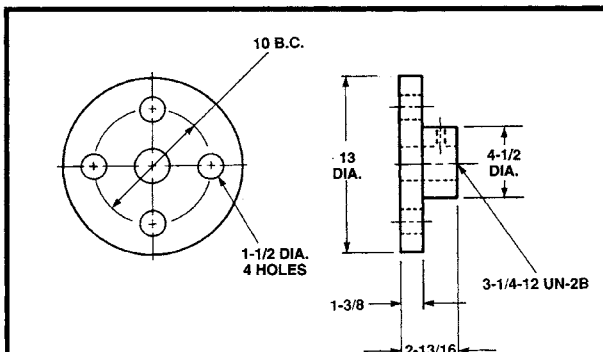

Top Plate (Optional)
SK2800-1-60A

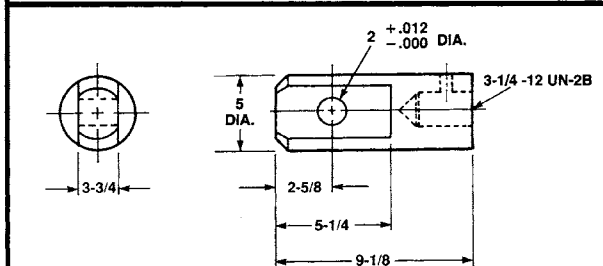

Clevis End (Optional)
SK2800-4-60A

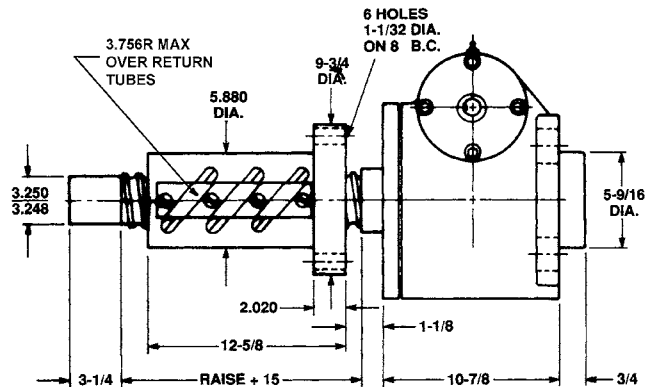

Upright Rotating: UM-2861

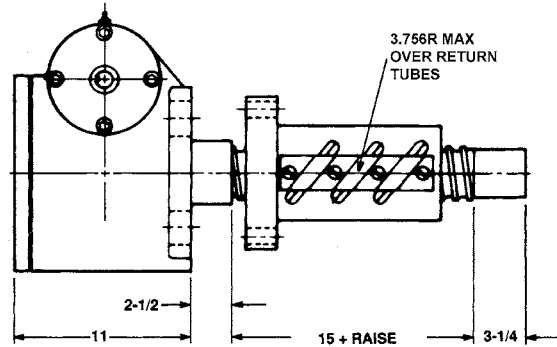

Inverted Rotating: DM-2861

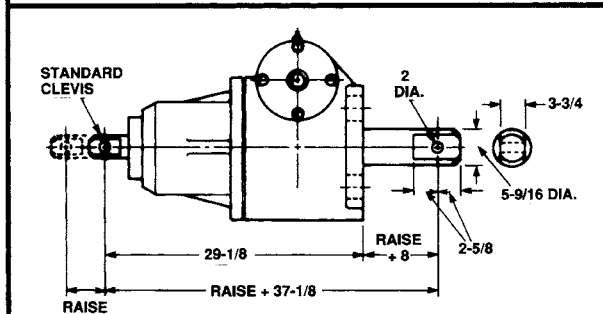

Double Clevis

Maximum Allowable Raise in Compression 65" - Rating 62,000 Lbs.
Maximum Raise at Rated Load in Compression 47".

Note: Lifting screw is not keyed. Top should be secured to a lifting member to prevent rotation. When a Bellows Boot is required, see pages 146-147. Dimensions are subject to change without notice.

CONTINUOUS DUTY CYCLE ACTUATOR

Features

- Predictable life.
- Continuous operation.
- Oil lubricated.
- High mechanical and thermal efficiency.
- 12 models available.
- Capacity 3,500 to 27,000 lbs.
- Available with C-Face motor adaptors and speed reducers.

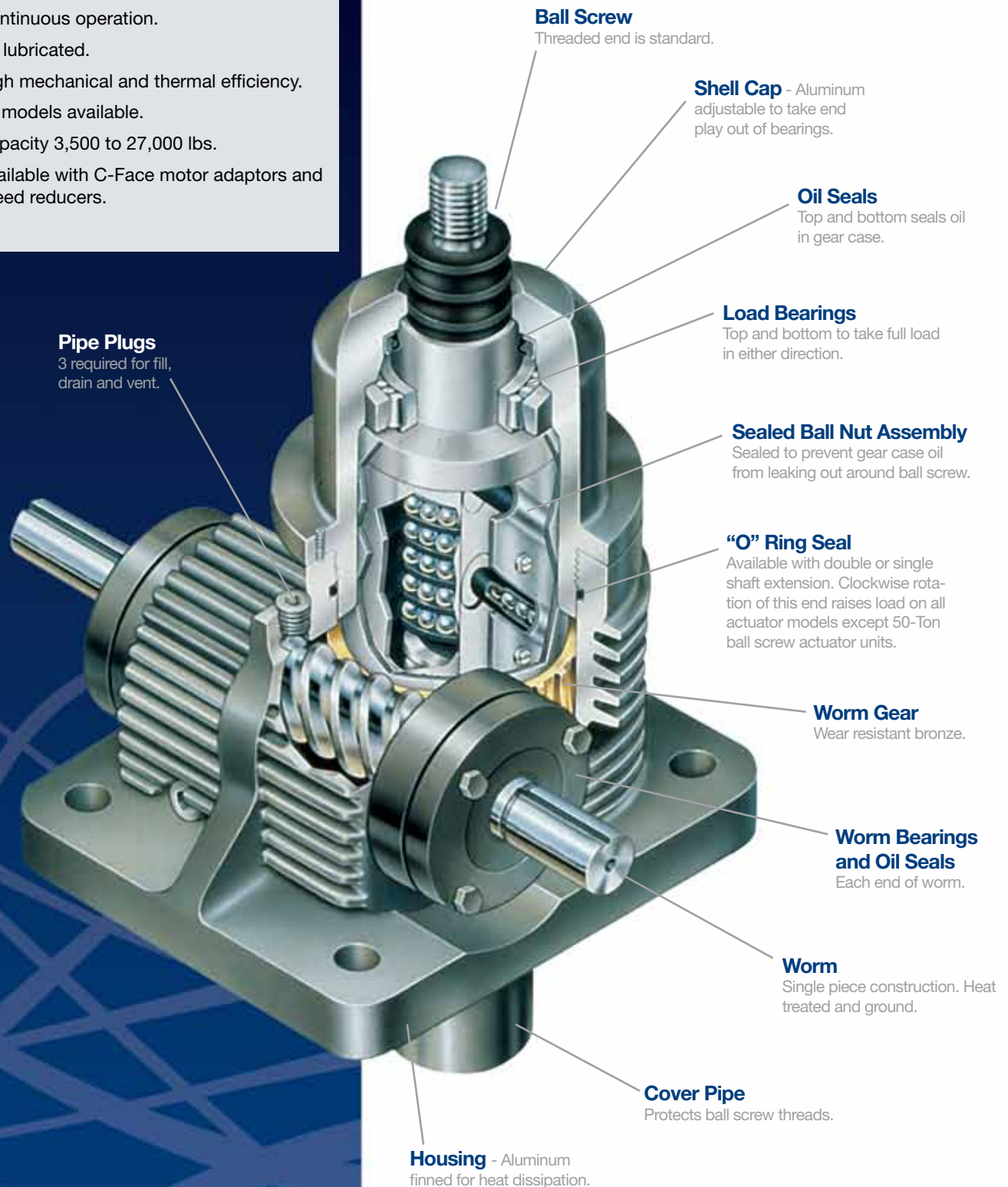

FL - TKM - 7515 - 6 - 1R

Model Prefix

R - Reducer
F - C-face Adapter
L - Limit Switch
E - Encoder
J - Rotary Counter

Screw End & Configuration

T - Threaded End
C - Clevis End
M - Top Plate
P - Plain End

K - Anti-Rotation Screw
CC - Double Clevis

D - Inverted Rotating
U - Upright Rotating

Series & Capacity No.

Series:
Standard Models (75xx, 7511, 7515, 7522)
Special Models (85xx, 8511, 8515, 8522)

Capacities:
Upright model suffixes end as shown.
Inverted model suffixes lower the capacity number by one digit.
Rotating model suffixes raise the capacity number by one digit.

M - Base Model

Travel

1" increment travels are always represented using the exact travel amount.

Travels with fractional lengths are quoted using that length, but are serialized when the order is processed.

Serialized digits in this position may also be used for other models containing special features.

Model Suffix

B - Boot
L - Single End Worm Ext. Left
R - Single End Worm Ext. Right
1 - Optional Ratio #1
2 - Optional Ratio #2
X - Supplied without cover pipe

CONTINUOUS DUTY CYCLE ACTUATORS

Continuous Duty Cycle Performance Table

Features

- 25 configured models available. Upright or inverted translating screw, rotating screw available and double clevis.
- Maximum load capacities range from 3,500 to 27,000 pounds.
- Rated load capacities (load at which actuator life is 1,000 hours) range from 2,000 to 13,000 lbs.
- High mechanical efficiency - The unit's mechanical efficiency (as high as 70%) is due to the heat-treated ball bearing screw and mating nut, hardened and ground alloy steel worm, wear resistant bronze worm gear and oil bath lubrication.
- High thermal efficiency - The continuous duty cycle actuator units have high thermal efficiency (100% on-time at rated loads and at least 33% on-time at maximum loads)
- High speed - Designed to run at a worm speed of 1750 rpm fully loaded. Higher speeds possible with less than capacity loads. Screw speed up to 120 inches per minute.
- Positive action - High reliability; needs no pumps, hoses or valves. Can be synchronized for multiple usage.
- Less power required - Efficient design needs less power for given thrust; cuts power requirements.
- Worm gearing meets AGMA Standards.
- Sand-cast aluminum housings for added heat dissipation.
- Available with C-Face motor adaptors and reducers.

Duff-Norton 7500 Series high duty cycle actuators are specifically designed for continuous operation within certain load limitations (see Maximum Allowable Duty Cycle chart below). The precision worm gear set operates in an oil bath that improves thermal efficiency.

Maximum Allowable Duty Cycle at 1750 RPM Input Speed

Model No.	Max. Capacity	75% Max. Capacity	Rated Capacity
7511	100%	100%	100%
7515	33%	67%	100%
7522	33%	67%	100%

Note: Duty cycles are based on 100°F temperature rise above ambient not to exceed 200°F using Duff-Norton's standard oil.

In addition, the precision drive arrangement permits the accurate prediction of operating life in terms of millions of inches of travel. This important feature allows optimum maintenance and replacement scheduling, so as to minimize downtime.

Continuous Duty Cycle Actuator

Model No.	7511	7515	75151 (HL)	7522	75221 (HL)
Performance Specifications					
Max. Speed Cface Driven (in/min)** (pg. 114)	118.5	102.0	215.5	81.0	215.5
Max. Speed Reducer Driven (in/min)** (pg. 110)	23.0	20.0	43.0	16.0	32.0
Max. Load Capacity (lbs.)	3,500	12,000	5,500	27,000	13,500
Rated Load Capacity (lbs. - 1000 hours life)	2,000	5,200	3,200	13,000	12,000
Lifting Screw (Dia. x Lead)	1.17 x .413	1.50 x .474	1.5 x 1.00	2.25 x .500	2.25 x 1.0
Worm Gear Ratio	6:1	8:1	8:1	10 2/3:1	10 2/3:1
Turns of Worm for 1" Raise	14.526	16.889	8.000	21.333	10.667
Horsepower per Actuator (Max. @ 1750 RPM)	2	5	5	10	10
Key Torque (in-lb)	260	1000	975	2400	2400
Starting Torque (in-lb @ Max. Load)	75	200	450	420	825
Running Torque (in-lb @ Max. Load)	60	170	392	350	685
Hold Back Torque* (lb-ft at Max. Load)	4	9	9	12	12
Actuator Efficiency Rating (Percentage)	63.91	66.52	64.36	57.55	57.55
Weight with Base Raise of 6" (lbs.)	19	43	43	95	95
Weight for Each Additional 1" Raise (lbs.)	.4	.9	.9	1.5	1.5

*Note: Hold Back Torque is resisting torque at the worm shaft to keep load from running down.

All actuator units can be supplied with standard raises up to 24 inches. Special raises up to 20 feet are available upon request. Standard inverted keyed models do not have a cover pipe (except for the 1-Ton and 75-Ton models). Closed height dimensions may increase for actuators supplied with bellows boots. See page 146-147.

Note: See page 105 for ball screw and nut life expectancy

7500 Series with Translating Screw

Typical 7500 Series Actuator with Upright Translating Screw

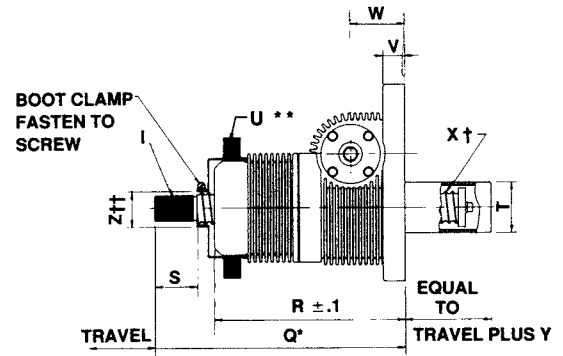
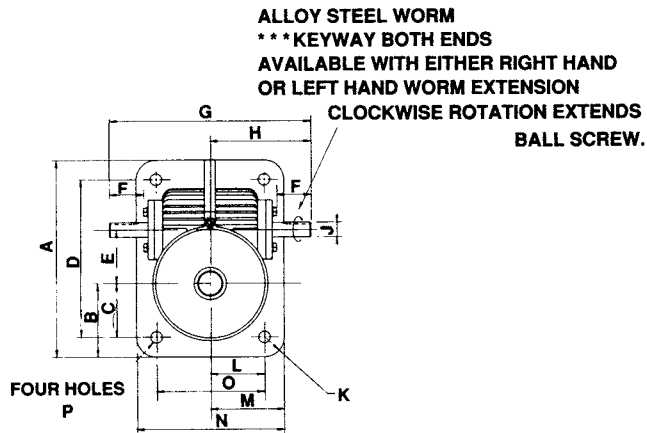

Typical 7500 Series Actuator with Inverted Translating Screw

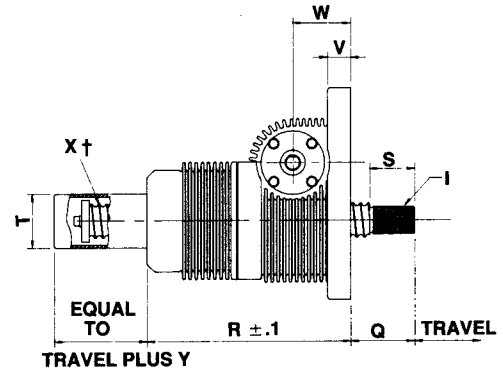
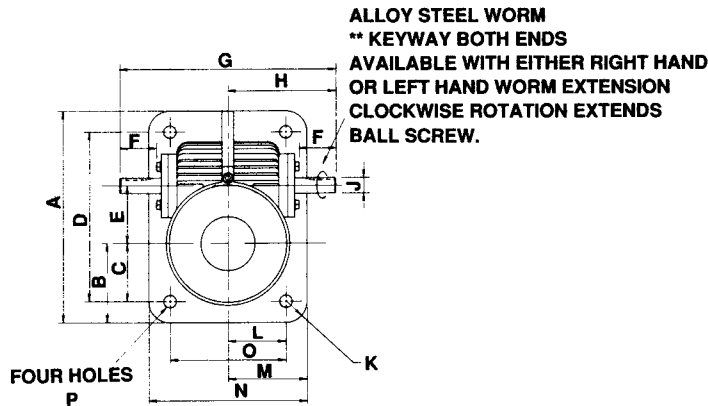

Continuous Duty Cycle Actuators

Model	Dimensions (inches)																									
	No.	A	B	C	D	E	F	G	H	I	J	K	L	M	N	O	P	Q*	R	S	T	U**	V	W	X†	Y
7511 Upright	7	2 3/4	2.20	6	+/- .001 1.703	1.12	8.6	4.3	3/4 16UNF -2A	+ .000 - .002 .500	1/2 R	2 1/4	2 3/4	5 1/2	4 1/2	13/32	+/- .06 10.4	+/- .06 8.4	1 1/8	1 21/32	7 0.D. X 4 I.D.	3/4	+/- .005 2.500	1.171 Dia. .413 Lead	2	1.5
7515 or 75151 Upright	8 3/4	2 7/8	2	7	+ .003 - .000 2.598	1.68	11	5.5	1 14UNS -2A	+ .000 - .002 1.000	7/8 R	2 7/8	3 3/4	7 1/2	5 3/4	11/16	+/- .1 11.2	+/- .1 9.2	1 1/8	2 3/8	7 0.D. X 4 3/4 I.D.	1	+/- .005 2.750	1.500 Dia. .474 Lead	2	-
7522 or 75221 Upright	13 3/4	5 1/8	3 3/4	11	+ .005 - .000 3.750	2.38	14	7.0	1 3/4 12UN -2A	+ .000 - .002 1.000	1 3/8 R	3 3/4	5 1/8	10 1/4	7 1/2	13/16	+/- .1 16.6	+/- .1 13.2	2 1/4	3 1/2	9.8 O.D. X 6.8 I.D.	1 1/2	+/- .005 3.7500	2.25 Dia. .500 Lead	3	-
7510 Inverted	7	2 3/4	2.20	6	+/- .001 1.703	1.12	8.6	4.3	3/4 16UNF -2A	+ .000 - .002 .500	1/2 R	2 1/4	2 3/4	5 1/2	4 1/2	13/32	+/- .06 10.4	+/- .06 8.4	1 1/8	1 21/32	7 0.D. X 4 I.D.	3/4	+/- .005 2.500	1.171 Dia. .413 Lead	2	-
7514 or 75141 Inverted	8 3/4	2 7/8	2	7	+ .003 - .000 2.598	1.68	11	5.5	1 14UNS -2A	+ .000 - .002 1.000	7/8 R	2 7/8	3 3/4	7 1/2	5 3/4	11/16	+/- .1 11.2	+/- .1 9.2	1 1/8	2 3/8	7 0.D. X 4 3/4 I.D.	1	+/- .005 2.750	1.500 Dia. .474 Lead	2	-
7521 or 75211 Inverted	13 3/4	5 1/8	3 3/4	11	+ .005 - .000 3.750	2.38	14	7.0	1 3/4 12UN -2A	+ .000 - .002 1.000	1 3/8 R	3 3/4	5 1/8	10 1/4	7 1/2	13/16	+/- .1 16.6	+/- .1 13.2	2 1/4	3 1/2	9.8 O.D. X 6.8 I.D.	1 1/2	+/- .005 3.7500	2.250 Dia. .500 Lead	3	-

*Closed height †Dimension includes diameter of ball screw with indicated lead for right-hand single thread.

Bellows boot (optional) ††Hub Dia. for boot attachment *Keyway for Model 7511 is 1/8 x 5/64 x 15/16 LG.

NOTE: When ordering, specify load and duty cycle. Keyway for Model 7515 & 7522 is 1/4 x 1/8 x 1 1/2

CONTINUOUS DUTY CYCLE ACTUATORS

7500 Series with Rotating Screw

Typical 7500 Series Actuator with Upright Rotating Screw

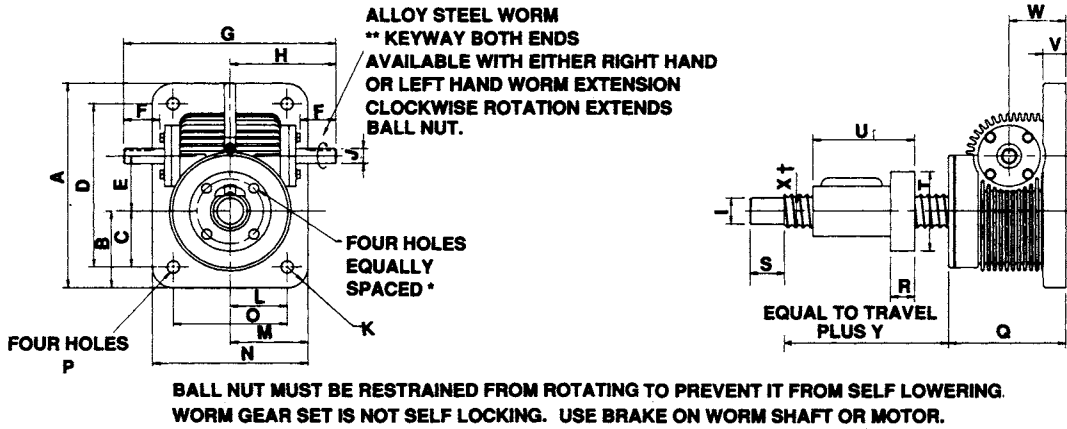

Typical 7500 Series Actuator with Inverted Rotating Screw

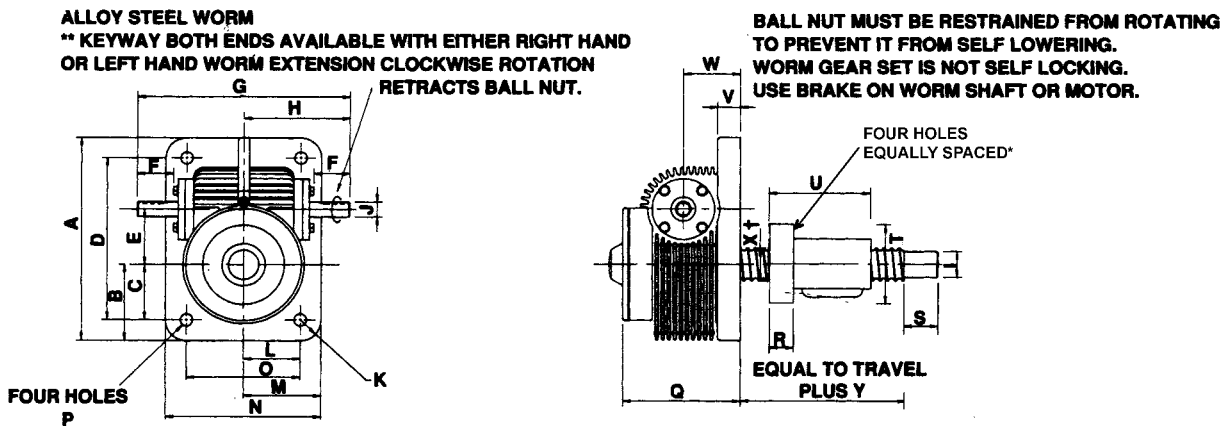

Continuous Duty Cycle Actuators

Model	Dimensions (inches)																								
	No.	A	B	C	D	E	F	G	H	I	J	K	L	M	N	O	P	Q	R	S	T	U	V	W	X†
UM7512 Upright	7	2 3/4	2.20	6	+/--.001 1.703	1.12	8.6	4.3	+0.000 -.002 .750	+0.000 -.002 .500	1/2 R	2 1/4	2 3/4	5 1/2	4 1/2	13/32	+/--.1 5 1/4	.832	1.13	4.250	3.395	3/4	+/--.005 2.500	1.171 Dia. .413 Lead	3.75
UM7516 or UM75161 Upright	8 3/4	2 7/8	2	7	+0.003 -.000 2.598	1.68	11	5.5	+0.000 -.002 1.000	+0.000 -.002 1.000	7/8 R	2 7/8	3 3/4	7 1/2	5 3/4	11/16	+/--.1 5 3/4	.895	1	4.937	4.33 Std or 3.65 HL	1	+/--.005 2.750	1.500 Dia. .474 Lead	4.75
UM7523 or UM75231 Upright	13 3/4	5 1/8	3 3/4	11	+0.005 -.000 3.750	2.38	14	7.0	+0.000 -.002 1.750	+0.000 -.002 1.000	1 3/8 R	3 3/4	5 1/8	10 1/4	7 1/2	13/16	+/--.1 7 3/4	+/- 1.582	2 1/4	5.375	6.706 Std or 6.739 HL	1 1/2	+/--.005 3.7500	2.250 Dia. .500 Lead	8.0
DM7512 Inverted	7	2 3/4	2.20	6	+/--.001 1.703	1.12	8.6	4.3	+0.000 -.002 .750	+0.000 -.002 .500	1/2 R	2 1/4	2 3/4	5 1/2	4 1/2	13/32	+/--.1 5 1/4	.832	1.13	4.250	3.395	3/4	+/--.005 2.500	1.171 Dia. .413 Lead	3.75
DM7516 or DM75161 Inverted	8 3/4	2 7/8	2	7	+0.003 -.000 2.598	1.68	11	5.5	+0.000 -.002 1.000	+0.000 -.002 1.000	7/8 R	2 7/8	3 3/4	7 1/2	5 3/4	11/16	+/--.1 5 3/4	.895	1	4.937	4.33 Std or 3.65 HL	1	+/--.005 2.750	1.500 Dia. .474 Lead	4.75
DM7523 or DM75231 Inverted	13 3/4	5 1/8	3 3/4	11	+0.005 -.000 3.750	2.38	14	7.0	+0.000 -.002 1.750	+0.000 -.002 1.000	1 3/8 R	3 3/4	5 1/8	10 1/4	7 1/2	13/16	+/--.1 7 3/4	+/- 1.582	2 1/4	5.375	6.706 Std or 6.739 HL	1 1/2	+/--.005 3.7500	2.250 Dia. .500 Lead	8.0

†Dimension includes diameter of ball screw with indicated lead for right-hand single thread **Keyway for Model UM-7512 is 1/8 x 5/64 x 15/16 LG. Keyway for Models UM-7516 & UM-7523 is 1/4 x 1/8 x 1 1/2. NOTE: When ordering, specify load and duty cycle.

*Model No. UM-7516: 17/32 dia. on 4.06 dia. bolt circle. Model No. UM-7523: 21/32 dia. on 4.375 dia. bolt circle. Model No. UM-7512: 25/64 dia. on 3.44 dia. bolt circle.

7500 Series Standard Screw Ends

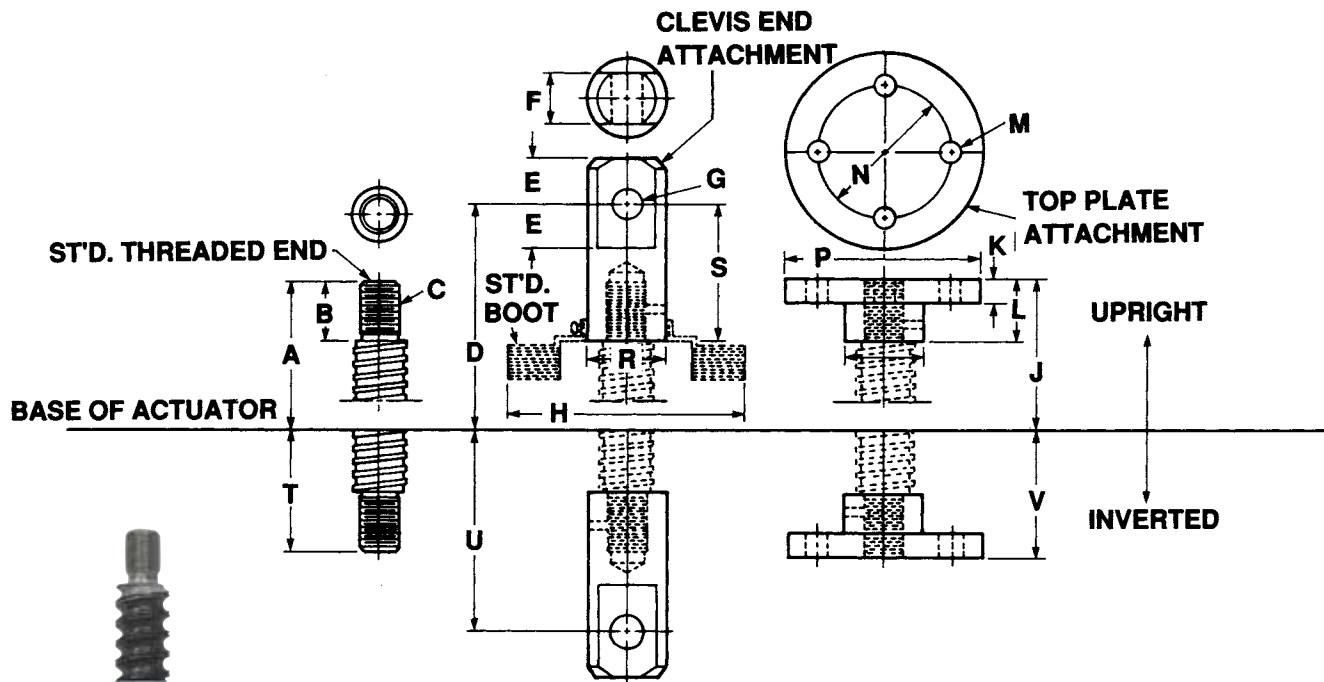

Model No.	Dimensions (inches)									
No.	A*	B	C	D*	E	F	G	H	J*	
7511	10 3/8	1 1/8	3/4"-16-UNF-2A	11 1/2	3/4	1	1/2" +.008/-0.000	7	10 7/16	
7515	11 1/4	1 1/8	1"-14-UNS-2A	13	1 1/4	1 1/4	3/4" +.010/-0.000	7	11 1/4	
7522	16 5/8	2 1/4	1 3/4"-12-UN-2A	19 1/8	1 3/4	1 3/4	1 1/4" +.010/-0.000	9 13/16	16 5/8	

Model No.	Dimensions (inches)										
No.	K	L	M	N	P	R	S	T*	U*	V*	
7511	7/16	1 3/16	13/32	3	4 1/4	1 1/2	2 1/4	2	3 1/8	2 1/16	
7515	5/8	1 1/4	11/16	3 1/2	5	1 3/4	2 7/8	2	3 3/4	2 1/16	
7522	1	2 5/16	13/16	5	7	2 5/8	4 3/4	3 3/8	5 7/8	3 7/16	

*Closed dimensions may increase for actuator units supplied with bellows boots. Call Factory.
 Note: Lifting screws listed above are not yet keyed. Must be held to prevent rotation.

G SERIES METRIC MACHINE SCREW ACTUATOR

50 kN to 200kN

Duff-Norton metric actuators are manufactured to the same high quality standards and include all the same features and benefits as the standard line of actuators while incorporating the following features.

Features

- Load Capacities in Tonnes
- Mounting dimensions in millimeters
- Metric screw diameters with trapezoidal threads (machine screw actuators)
- Metric shaft and keyway sizes per ISO recommended standards
- All metric fasteners on machine screw units
- Metric bolt centers
- Other sizes and models available, contact Duff-Norton for more information



www.duffnorton.com • Ph: (800) 477-5002 • Fax: (704) 588-1994

FL - GKM - 9002 - 120 - 1R

Model Prefix

- R** - Reducer
- F** - C-face or B-face Adapter
- H** - Hand Wheel
- L** - Limit Switch
- E** - Encoder
- J** - Rotary Counter

- G** - Base Model

Screw End & Configuration

- T** - Threaded End
- C** - Clevis End
- M** - Top Plate
- P** - Plain End

- K** - Keyed Screw
- CC** - Double Clevis

- D** - Inverted Rotating
- U** - Upright Rotating

Series & Capacity No.

- Series:**
 50kN - 200kN
 Machine Screw (90xx)
 Special MS (100xx)
- 5kN - 25kN
 Machine Screw (2625, 2501, 9002)
 Special MS (3625, 3501, 10002)

- Capacities:**
 50kN - 200kN:
 Upright model suffixes end with the capacity number.
 Inverted model suffixes lower the capacity number by one digit.
 Rotating model suffixes raise the capacity number by one digit.
- 5kN -25kN:
 Upright model suffixes lower the capacity number by one digit.
 Rotating model suffixes raise the capacity number by one digit.

Travel

- 1 mm increment travels are always represented using the exact travel amount.
- Serialized digits in this position may also be used for other models containing special features

Model Suffix

- B** - Boot
- L** - Single End Worm Ext. Left
- R** - Single End Worm Ext. Right
- 1** - Optional Ratio #1
- 2** - Optional Ratio #2
- X** - Supplied without cover pipe, but with guide bushing.

METRIC MACHINE SCREW ACTUATORS

Performance Specifications

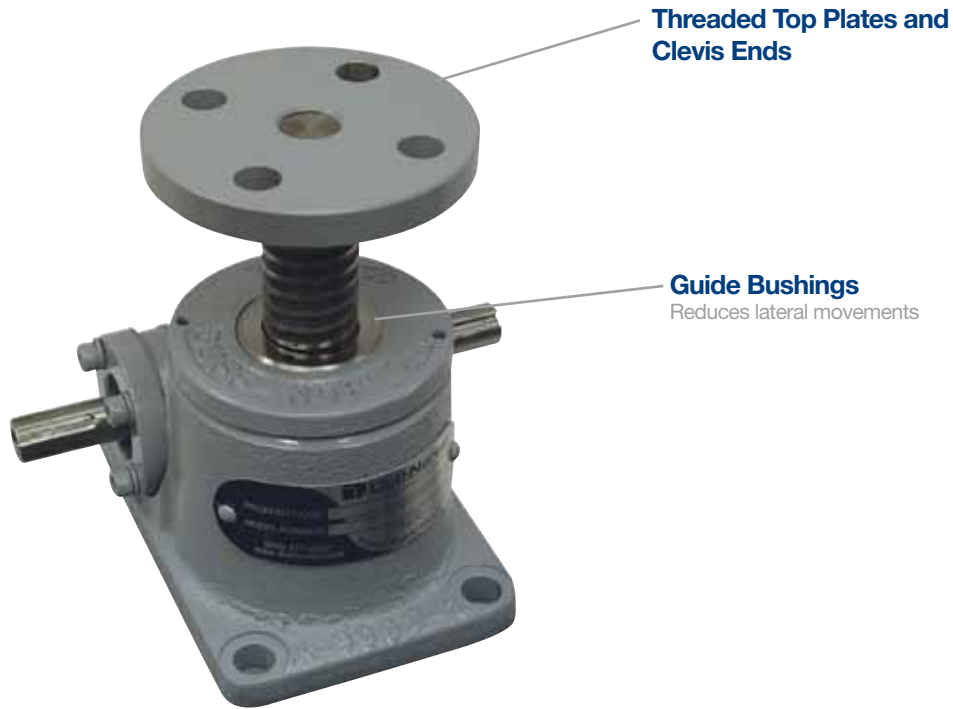

Metric Machine Screw Actuator

Capacity (kN)		5	10	25	50	100	150	200	300	500
Lifting Screw	Diameter (mm)	16	20	30	38	52	58	65	95	115
	Lead (mm)	3	5	6	9	12	12	12	16	16
	Type	Metric Trapezoidal	Metric Trapezoidal	Metric Trapezoidal	Metric Trapezoidal	Metric Trapezoidal	Metric Trapezoidal	Metric Trapezoidal	Metric Trapezoidal	Metric Trapezoidal
Worm Gear Ratios	Std.	5:1	5:1	6:1	6:1	8:1	8:1	8:1	10 2/3:1	10 2/3:1
	Optional No. 1	—	20:1	24:1	24:1	24:1	24:1	24:1	32:1	32:1
	Optional No. 2	—	—	12:1	12:1	—	—	—	—	—
Travel per Worm Turn (mm)	Std.	0.60	1.00	1.00	1.50	1.50	1.50	1.50	1.50	1.50
	Optional No. 1	—	0.25	0.25	0.38	0.50	0.50	0.50	0.50	0.50
	Optional No. 2	—	—	0.50	0.75	—	—	—	—	—
Worm Torque at No Load (N-m)	Std.	0.23	0.56	0.56	1.13	2.26	2.26	3.39	5.65	11.3
	Optional No. 1	—	0.56	0.56	1.13	2.26	2.26	3.39	5.65	11.3
	Optional No. 2	—	—	0.56	1.13	—	—	—	—	—
Maximum Input Power (kW)	Std.	0.25	0.37	1.49	2.98	3.73	3.73	3.73	6.00	11.2
	Optional No. 1	—	0.19	0.37	0.56	1.12	1.12	1.12	1.86	4.50
	Optional No. 2	—	—	0.56	1.49	—	—	—	—	—
Worm Torque at Full Load (N-m)	Std.	2.83	7.53	20.10	56.78	117.1	189.2	275.4	505.7	915.5
	Optional No. 1	—	3.69	9.34	27.06	63.2	101.4	147.7	305.3	520.5
	Optional No. 2	—	—	12.80	36.65	—	—	—	—	—
Efficiency Rating (%)	Std.	16.9	21.1	19.8	21.0	20.4	18.9	17.3	14.2	13.0
	Optional No. 1	—	10.8	10.7	11.0	12.6	11.8	10.8	7.8	7.6
	Optional No. 2	—	—	15.5	16.3	—	—	—	—	—
Weight with 25mm Raise (kg)		1.04	2.27	7.71	15.88	23.59	29.94	42.18	100	173
Wt per Additional 25mm Raise (kg)		0.04	0.13	0.13	0.40	0.63	0.67	1.16	1.65	2.46
Key Torque (N-m)		8.48	22.80	76.61	213.37	579.94	943.98	1374.01	2954.25	5749.55
Max Worm Speed at Full Load (rpm)	Std.	844	469	708	501	304	188	129	113	117
	Optional No. 1	—	491	378	198	169	105	72	58	83
	Optional No. 2	—	—	418	388	—	—	—	—	—
Max Load at Max Power and 1450 rpm (kN)	Std.	2.73	2.69	11.84	16.62	19.42	17.90	15.57	20.32	34.54
	Optional No. 1	—	2.21	5.34	4.93	8.40	7.74	5.52	6.61	18.01
	Optional No. 2	—	—	6.39	12.22	—	—	—	—	—

*For loads from 25% to 100% of actuator capacity, torque requirements are approximately proportional to the load. Raises, measured in increments of 25mm, are available up to 6.1 meters, depending on lifting screw diameter and available bar stock length.

Note: Contact customer service for motorized performance.

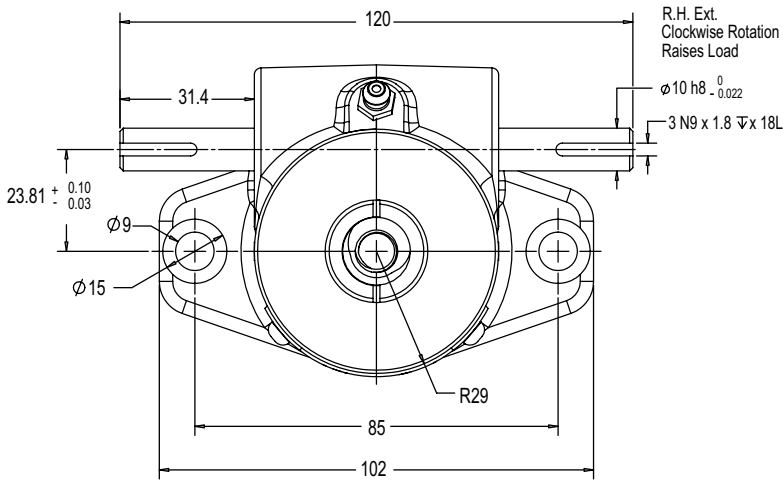

Top View: G2625
16mm Diameter x 3mm Lead Lifting Screw

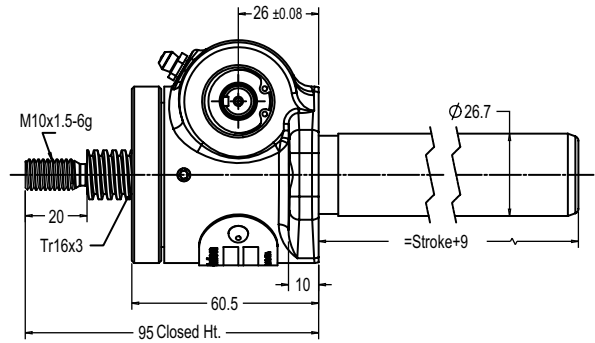

Upright: G2625

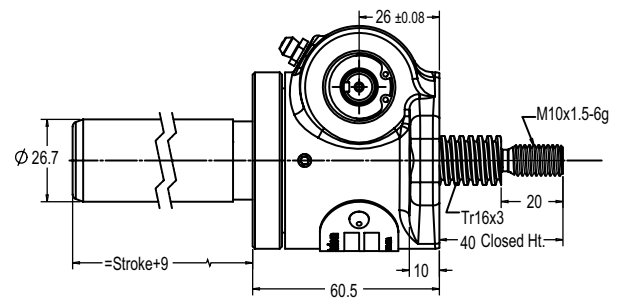

Inverted: G2624

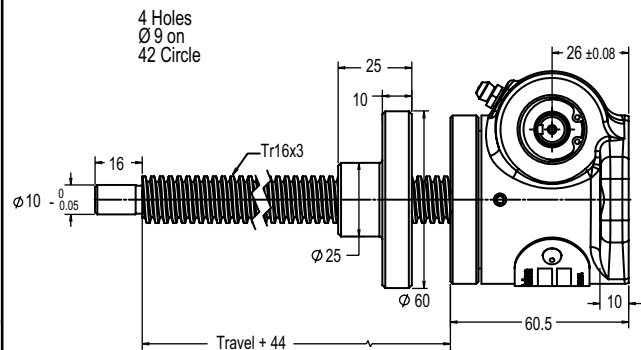
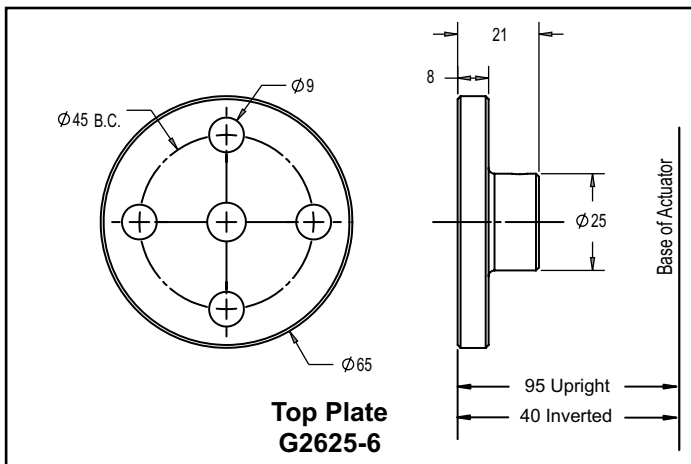

Upright Rotating: GU2626

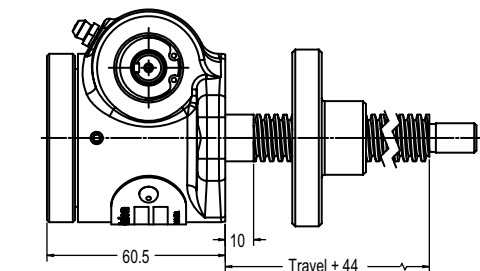
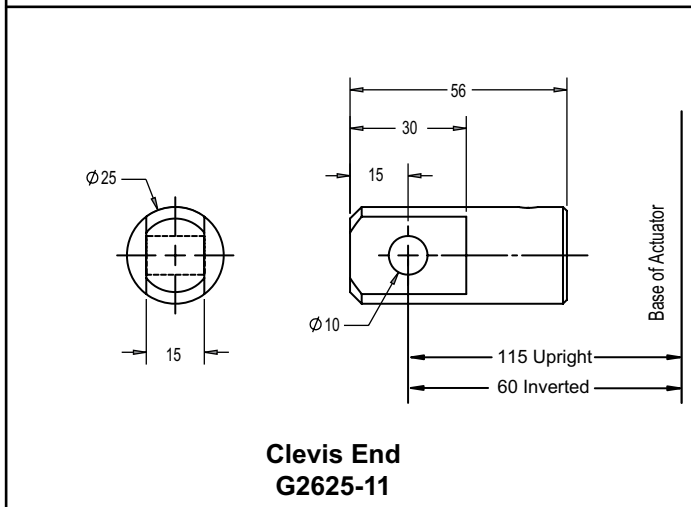

Inverted Rotating: GD2626

METRIC MACHINE SCREW ACTUATORS

10 kN Capacity

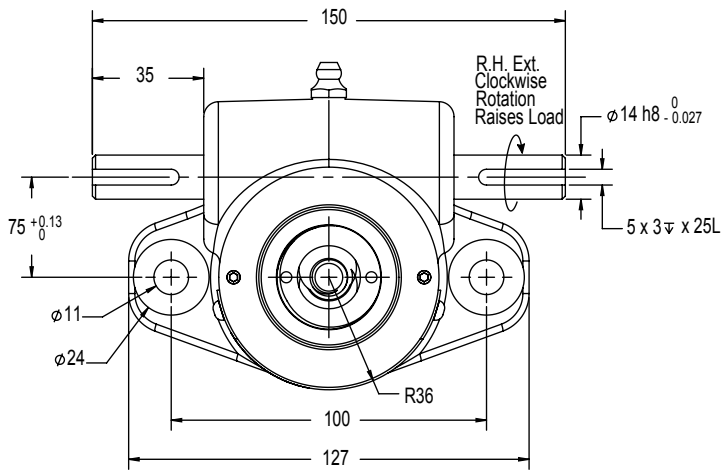

Top View: G2501

20mm O.D. 5mm Lead Lifting Screws

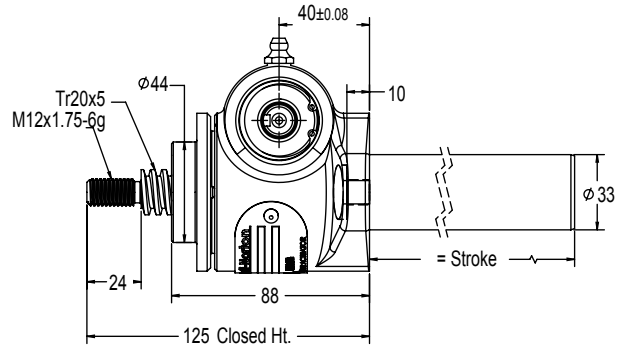

Upright: G2501

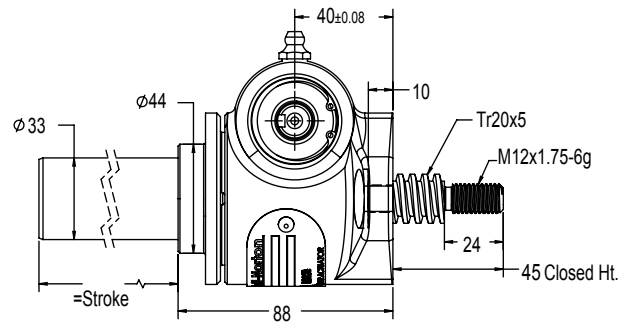

Inverted: G2500

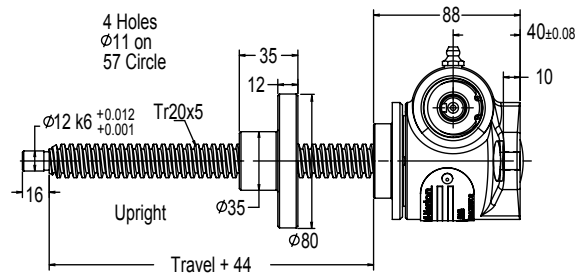

Upright Rotating: GU2502

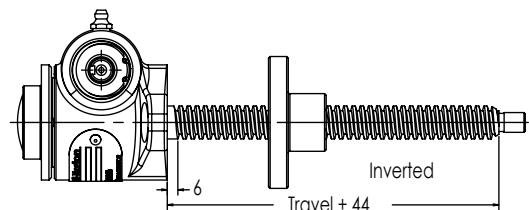

Inverted Rotating: GD2502

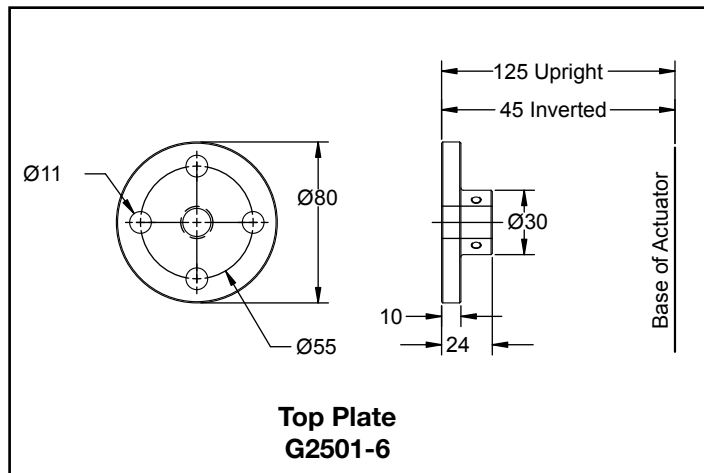

**Top Plate
G2501-6**

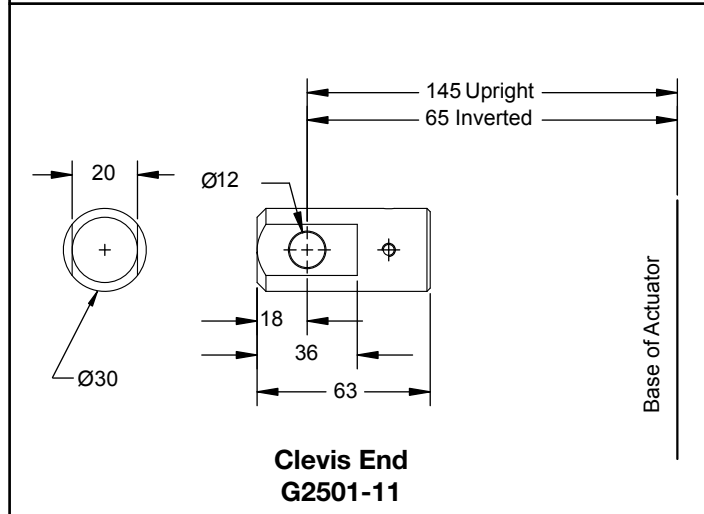

**Clevis End
G2501-11**

25 kN Capacity

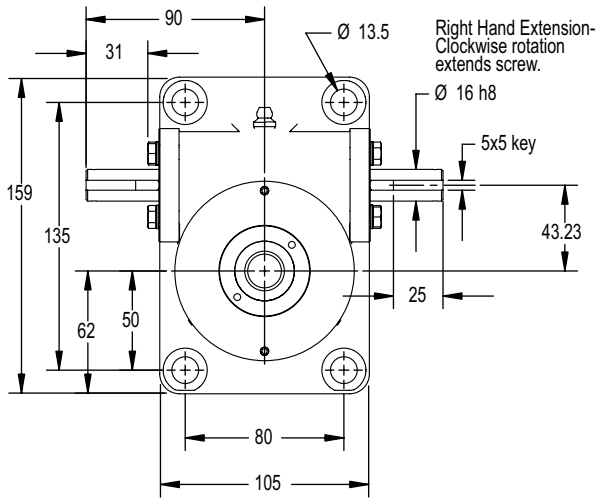

Top View: G9002

30mm O.D. 6mm Lead Lifting Screws

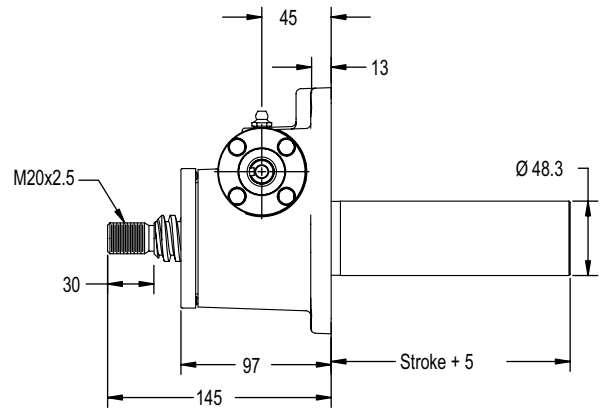

Upright: G9002

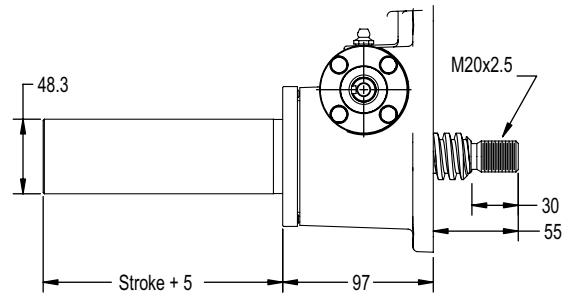

Inverted: G9001

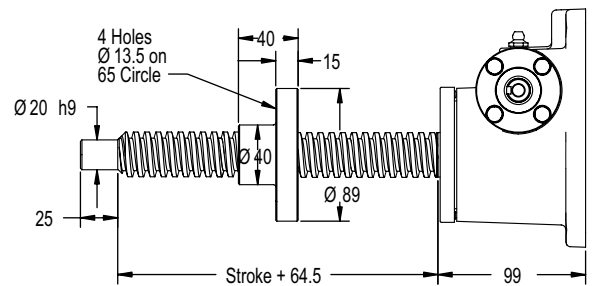

Upright Rotating: GU9003

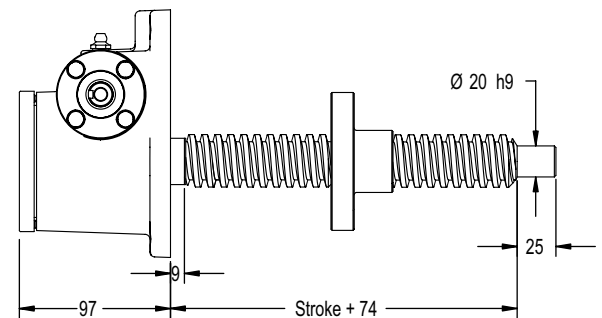

Inverted Rotating: GD9003

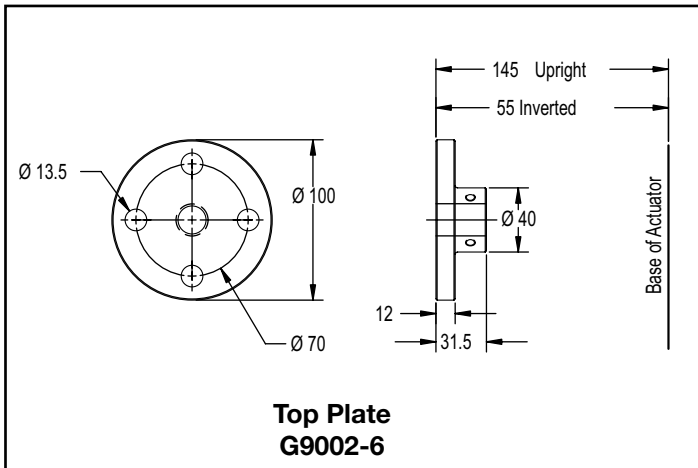

Top Plate G9002-6

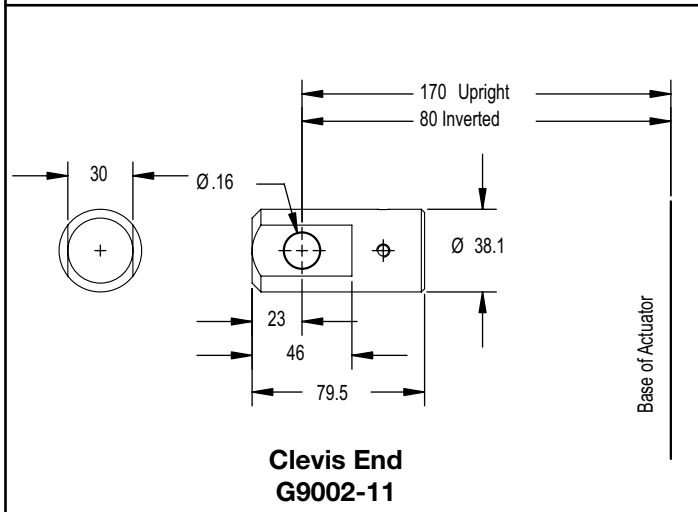

Clevis End G9002-11

METRIC MACHINE SCREW ACTUATORS

50 kN Capacity

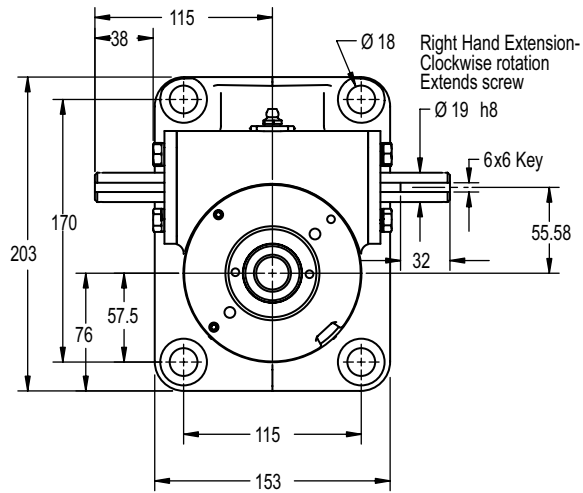

Top View: G9005

38mm O.D. 9mm Lead Lifting Screws

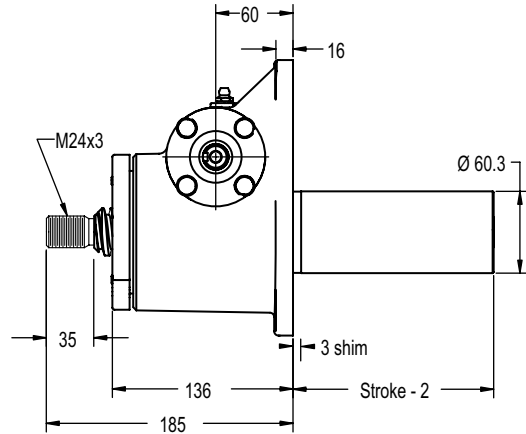

Upright: G9005

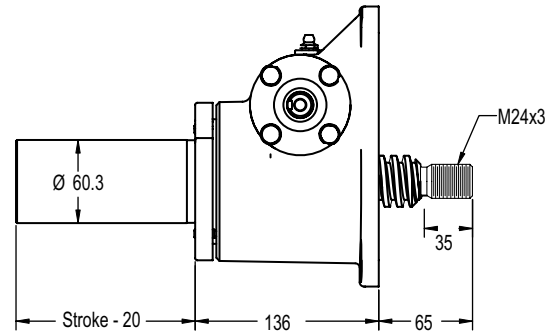

Inverted: G9004

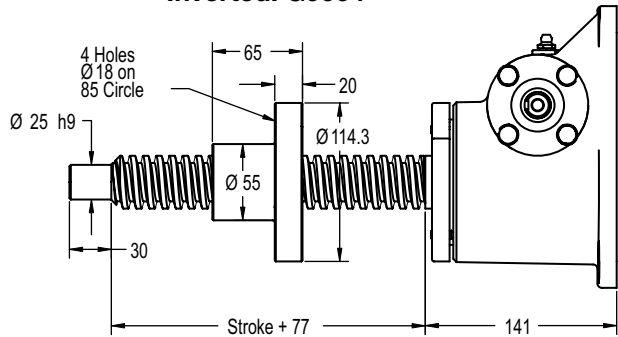

Upright Rotating: GU9006

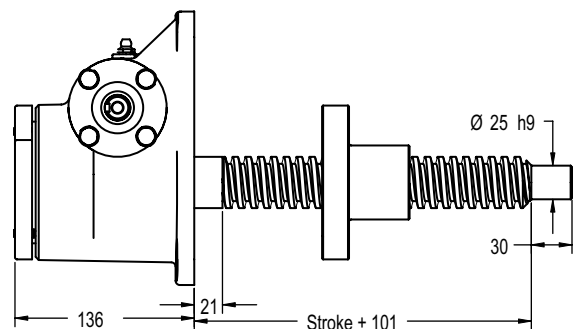

Inverted Rotating: GD9006

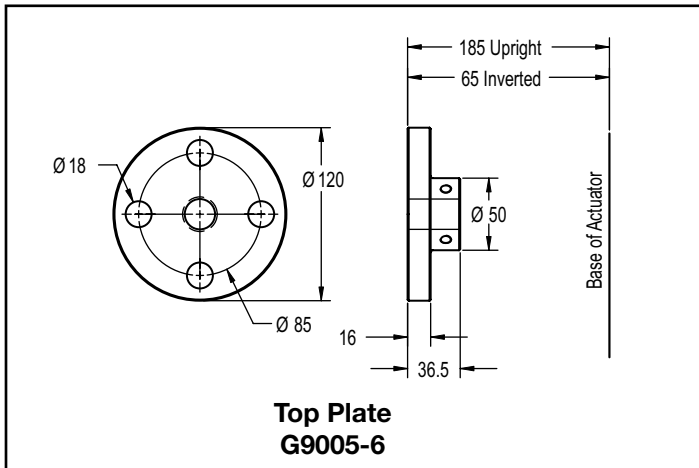

**Top Plate
G9005-6**

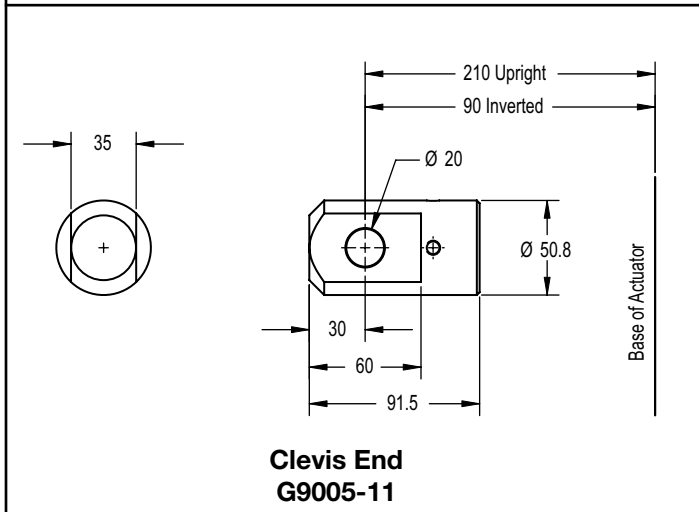

**Clevis End
G9005-11**

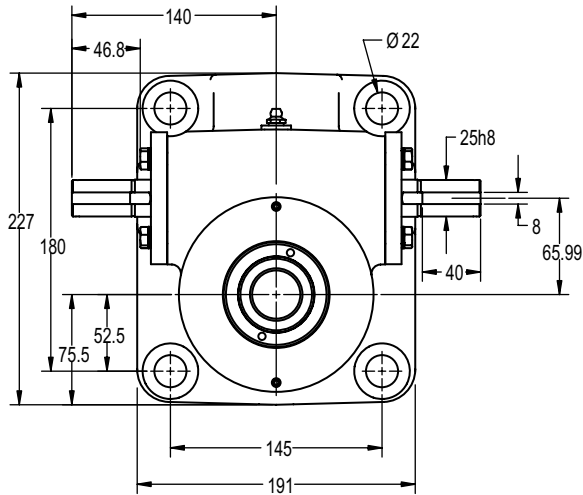

Top View: G9010

52mm O.D. x 12mm Lead Lifting Screws

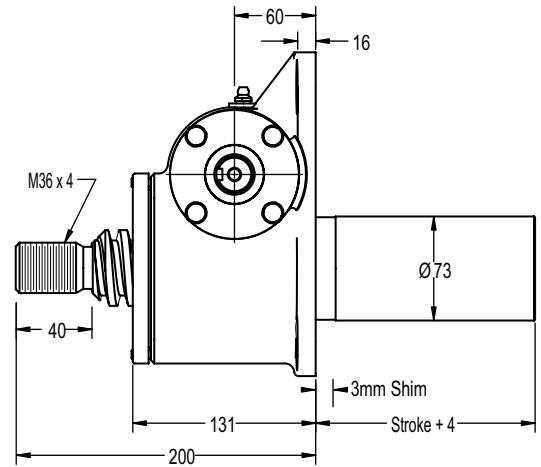

Upright: G9010

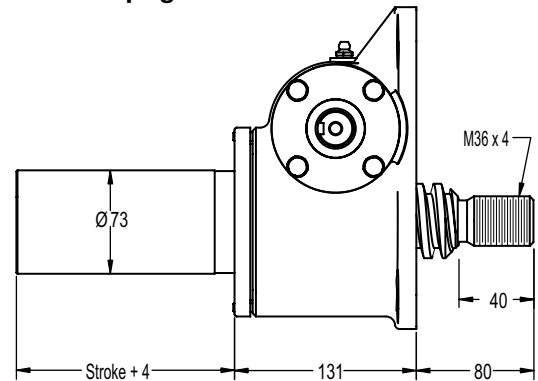

Inverted: G9009

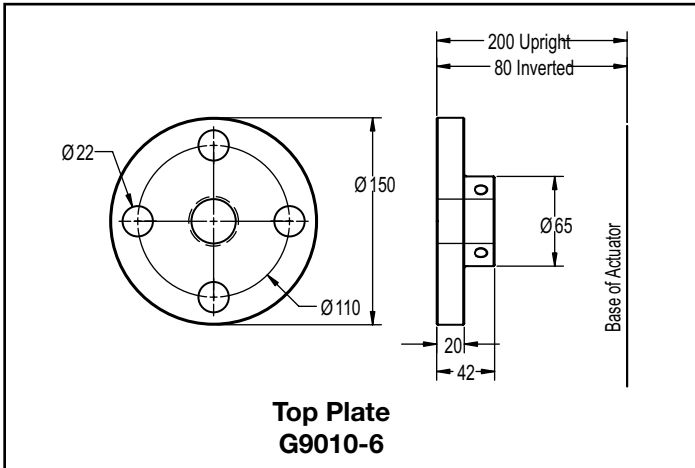

Top Plate
G9010-6

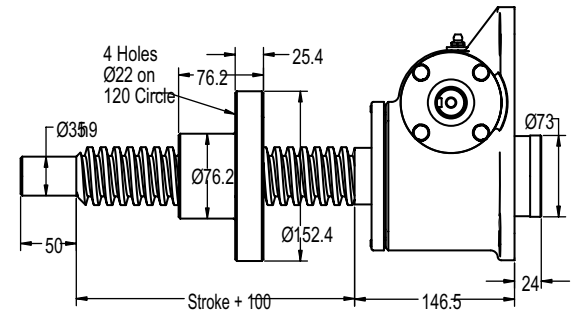

Upright Rotating: GU9011

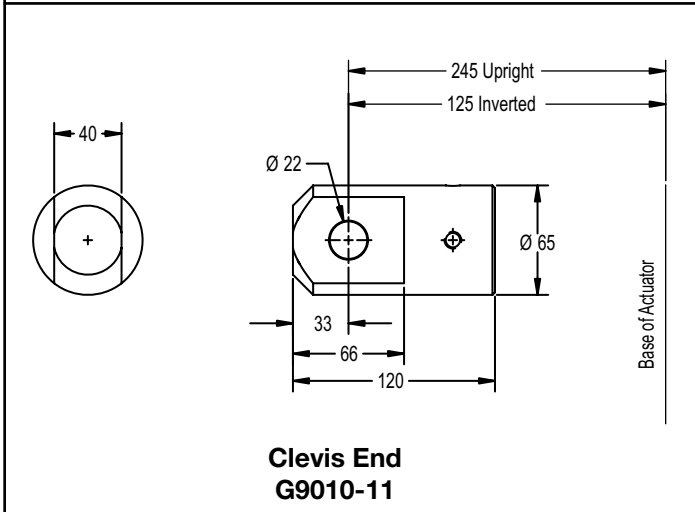

Clevis End
G9010-11

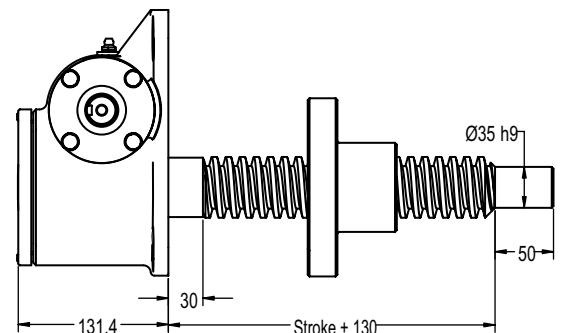

Inverted Rotating: GD9011

METRIC MACHINE SCREW ACTUATORS

150 kN Capacity

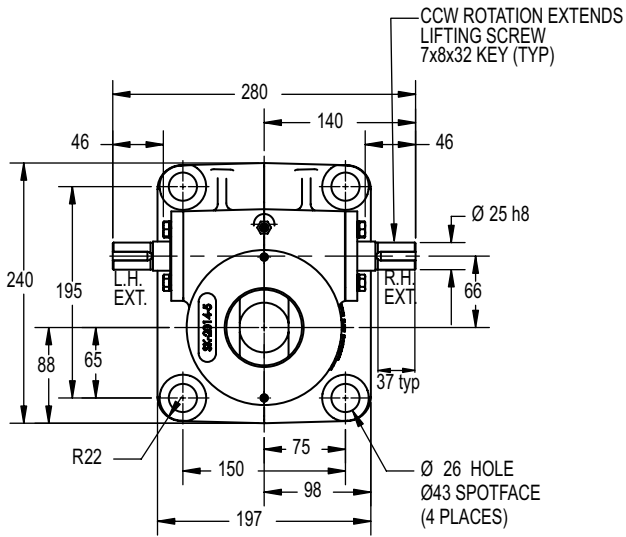

Top View: G9015

58mm O.D. x 12mm Lead Lifting Screws

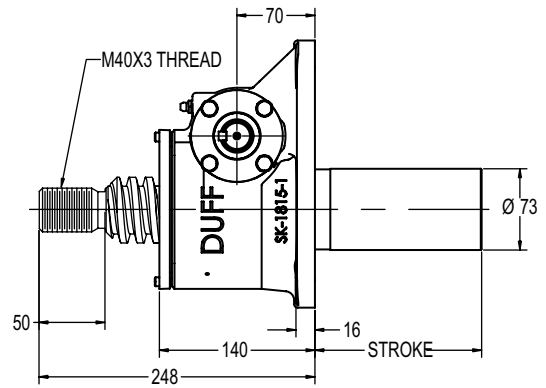

Upright: G9015

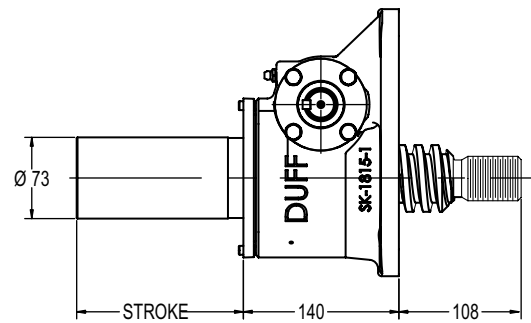

Inverted: G9014

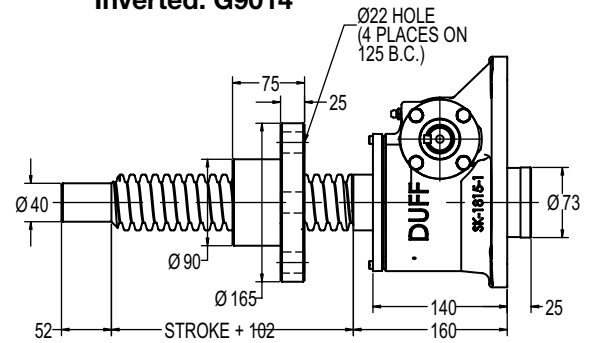

Upright Rotating: GU9016

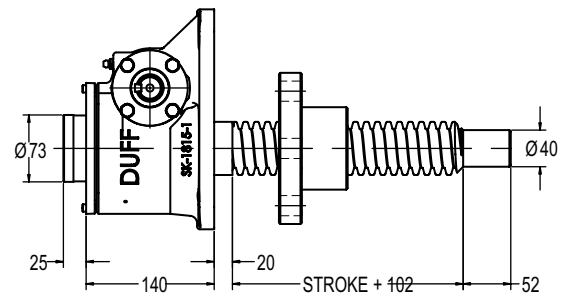

Inverted Rotating: GD9016

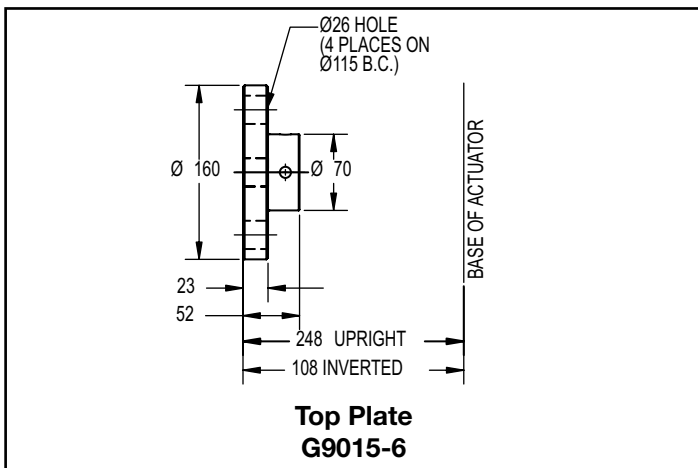

**Top Plate
G9015-6**

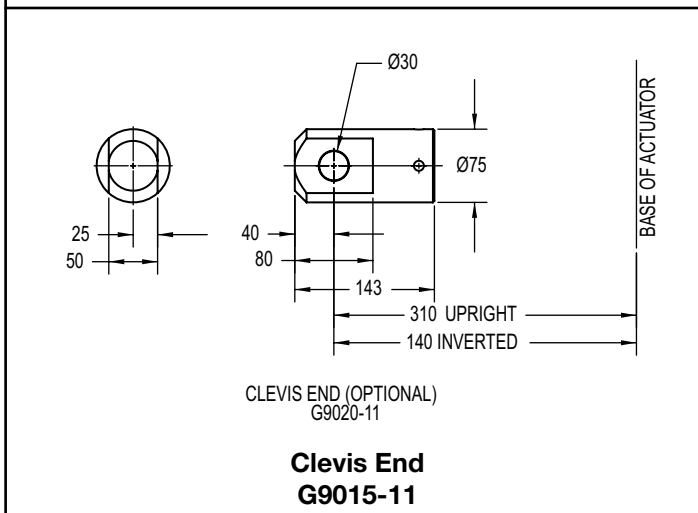

**Clevis End
G9015-11**

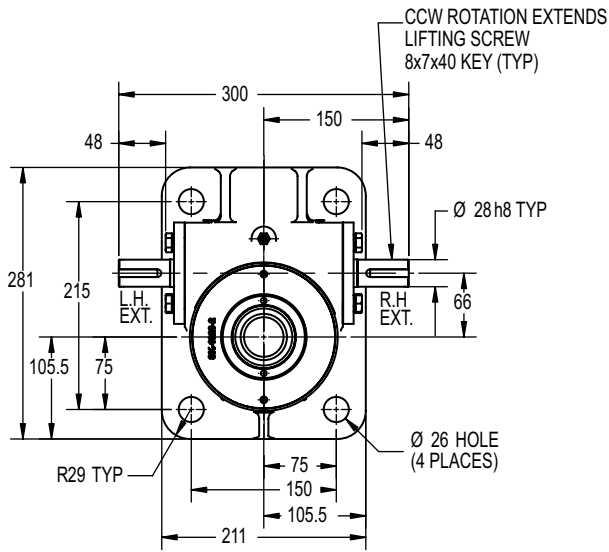

Top View: G9020

65mm O.D. x 12mm Lead Lifting Screws

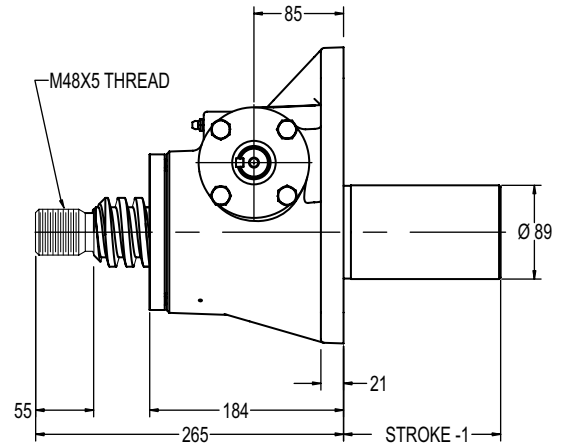

Upright: G9020

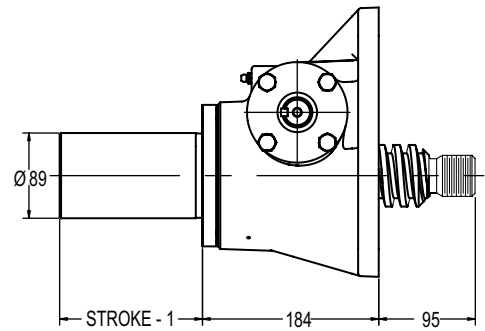

Inverted: G9019

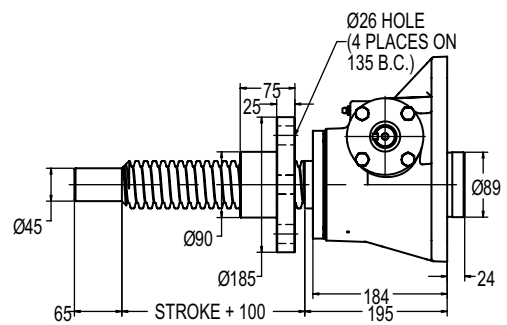

Upright Rotating: GU9021

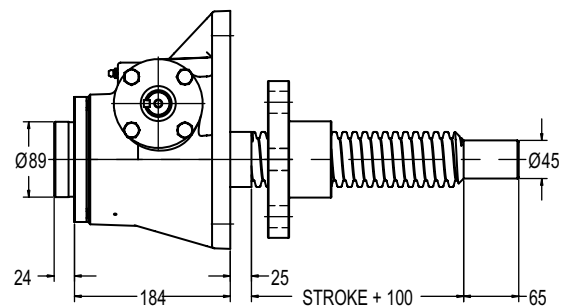

Inverted Rotating: GD9021

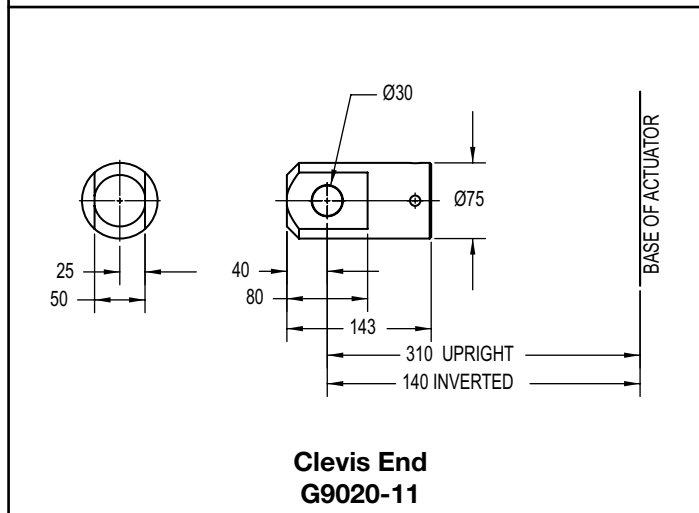
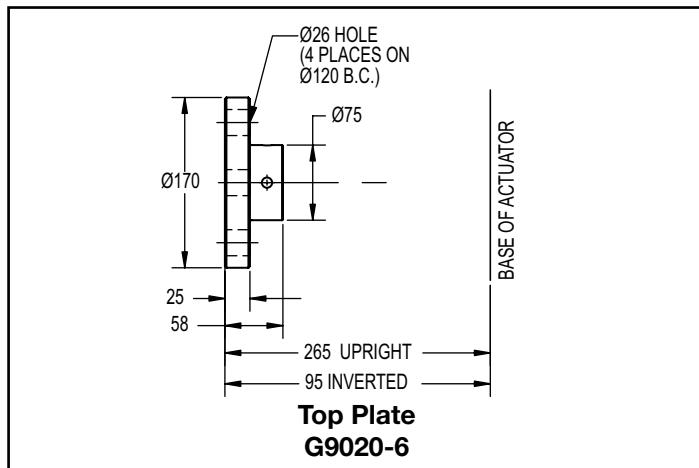

METRIC MACHINE SCREW ACTUATORS

300 kN Capacity

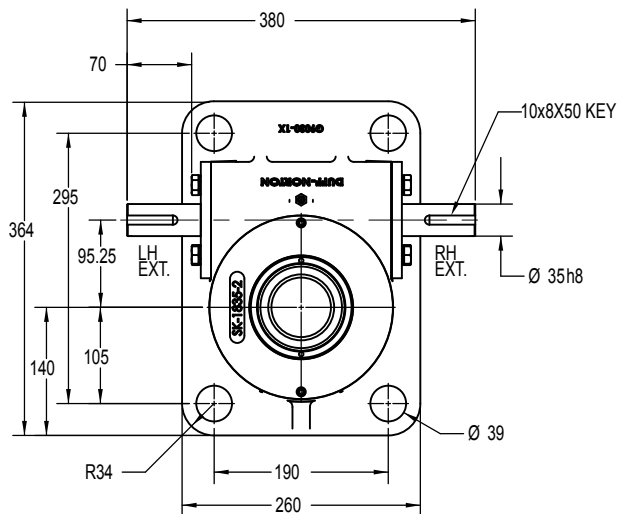

Top View: G9030

95mm O.D. x 16mm Lead Lifting Screws

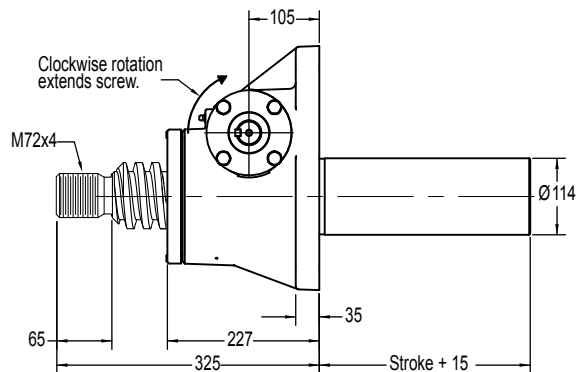

Upright: G9030

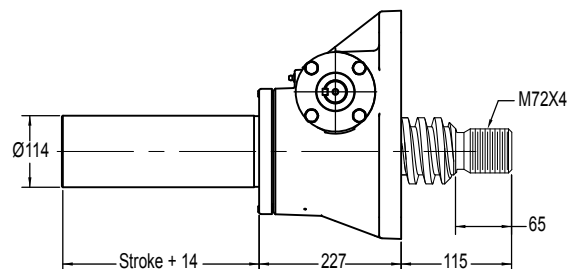

Inverted: G9029

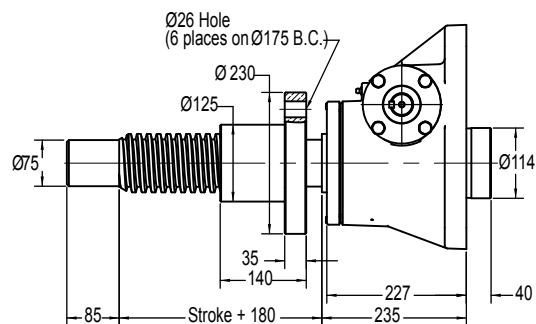

Upright Rotating: GU9031

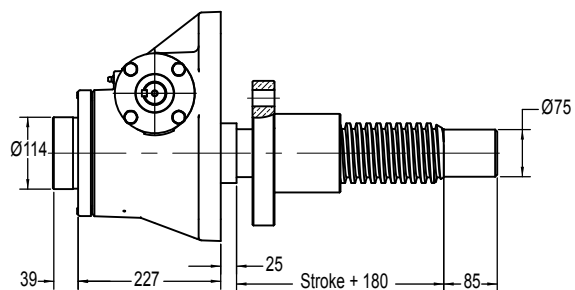

Inverted Rotating: GD9031

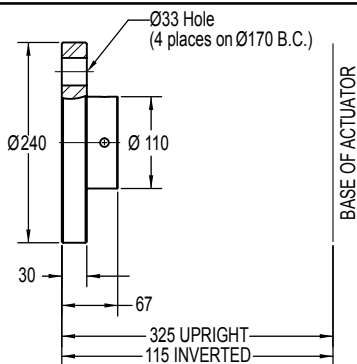

**Top Plate
G9030-6**

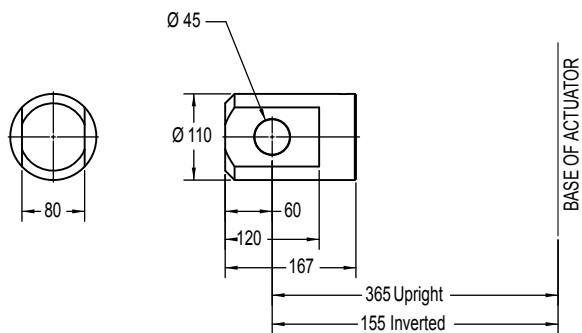

**Clevis End
G9030-11**

500 kN Capacity

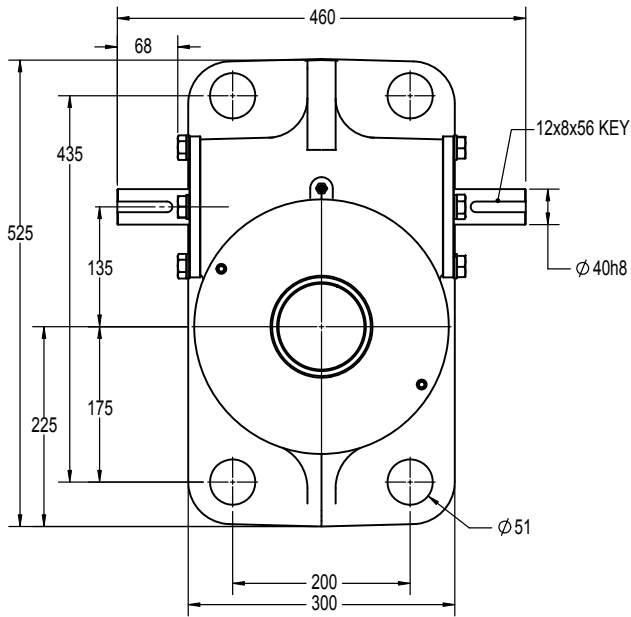

Top View: G9050

115mm O.D. x 16mm Lead Lifting Screws

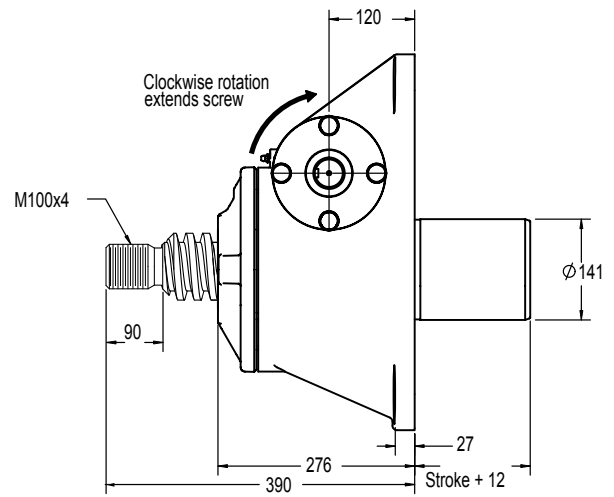

Upright: G9050

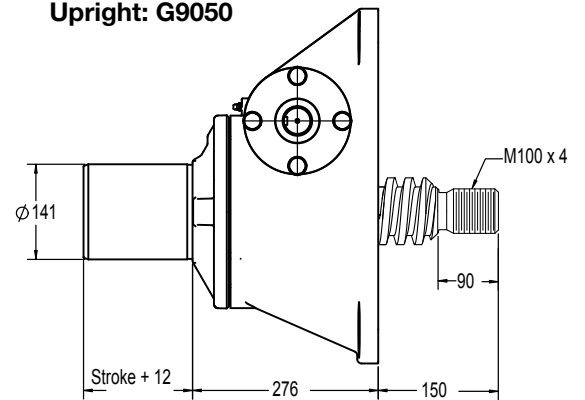

Inverted: G9049

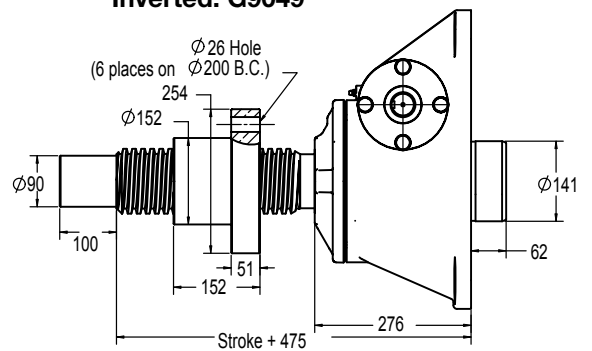

Upright Rotating: GU9051

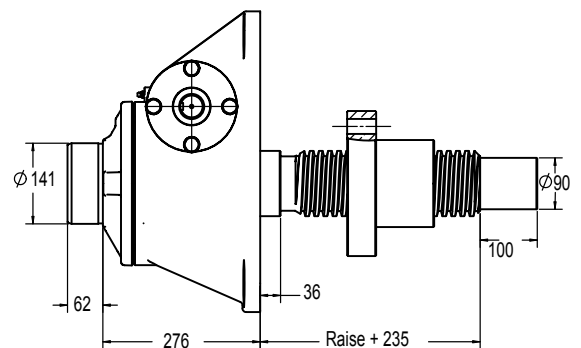

Inverted Rotating: GD9051

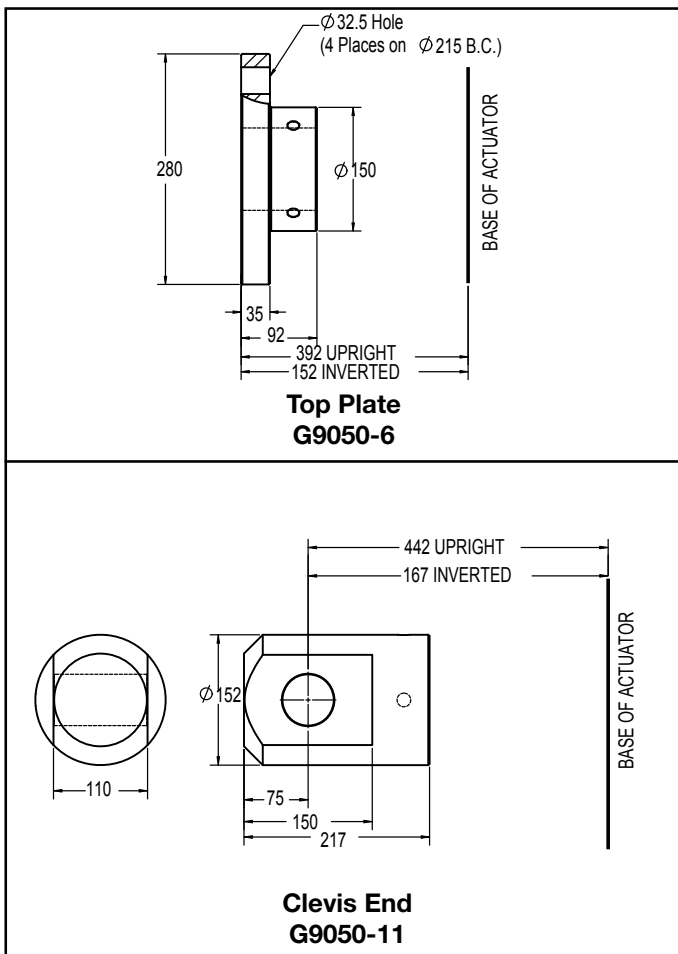

Top Plate
G9050-6

Clevis End
G9050-11

METRIC ANTI-BACKLASH ACTUATORS

Model Numbering System

FL - GKM - 9402 - 120 - 1R

Model Prefix

- R - Reducer
- F - C-face or B-face Adapter
- H - Hand Wheel
- L - Limit Switch
- E - Encoder
- J - Rotary Counter

- G - Base Model

Screw End & Configuration

- T - Threaded End
- C - Clevis End
- M - Top Plate
- P - Plain End

- K - Keyed Screw
- CC - Double Clevis

- D - Inverted Rotating
- U - Upright Rotating

Series & Capacity No.

- Series:**
- | | |
|----------------------|----------------------|
| 50kN - 200kN | 25kN |
| Anti-backlash (94xx) | Anti-backlash (9002) |
| Special AB (100xx) | Special AB (10002) |

- Capacities:**
- 50kN - 200kN:
- Upright model suffixes end with the capacity number.
Inverted model suffixes lower the capacity number by one digit.
Rotating model suffixes raise the capacity number by one digit.

- 25kN:
- Upright model suffix ends as shown.
Inverted model suffix lower the capacity number by one digit. Rotating model suffixes raise the capacity number by one digit.

Travel

1 mm increment travels are always represented using the exact travel amount.

Serialized digits in this position may also be used for other models containing special features

Model Suffix

- B - Boot
- L - Single End Worm Ext. Left
- R - Single End Worm Ext. Right
- 1 - Optional Ratio #1
- 2 - Optional Ratio #2
- X - Supplied without cover pipe, but with guide bushing.

Metric Machine Screw Actuator

Capacity (kN)		5	10	25	50	100	150	200	300	500
Lifting Screw	Diameter (mm)	16	20	30	38	52	58	65	95	115
	Lead (mm)	3	5	6	9	12	12	12	16	16
	Type	Metric Trapezoidal	Metric Trapezoidal	Metric Trapezoidal	Metric Trapezoidal	Metric Trapezoidal	Metric Trapezoidal	Metric Trapezoidal	Metric Trapezoidal	Metric Trapezoidal
Worm Gear Ratios	Std.	5:1	5:1	6:1	6:1	8:1	8:1	8:1	10 2/3:1	10 2/3:1
	Optional No. 1	—	20:1	24:1	24:1	24:1	24:1	24:1	32:1	32:1
	Optional No. 2	—	—	12:1	12:1	—	—	—	—	—
Travel per Worm Turn (mm)	Std.	0.60	1.00	1.00	1.50	1.50	1.50	1.50	1.50	1.50
	Optional No. 1	—	0.25	0.25	0.38	0.50	0.50	0.50	0.50	0.50
	Optional No. 2	—	—	0.50	0.75	—	—	—	—	—
Worm Torque at No Load (N-m)	Std.	0.23	0.56	0.56	1.13	2.26	2.26	3.39	5.65	11.3
	Optional No. 1	—	0.56	0.56	1.13	2.26	2.26	3.39	5.65	11.3
	Optional No. 2	—	—	0.56	1.13	—	—	—	—	—
Maximum Input Power (kW)	Std.	0.25	0.37	1.49	2.98	3.73	3.73	3.73	6.00	11.2
	Optional No. 1	—	0.19	0.37	0.56	1.12	1.12	1.12	1.86	4.50
	Optional No. 2	—	—	0.56	1.49	—	—	—	—	—
Worm Torque at Full Load (N-m)	Std.	2.83	7.53	20.10	56.78	117.1	189.2	275.4	505.7	915.5
	Optional No. 1	—	3.69	9.34	27.06	63.2	101.4	147.7	305.3	520.5
	Optional No. 2	—	—	12.80	36.65	—	—	—	—	—
Efficiency Rating (%)	Std.	16.9	21.1	19.8	21.0	20.4	18.9	17.3	14.2	13.0
	Optional No. 1	—	10.8	10.7	11.0	12.6	11.8	10.8	7.8	7.6
	Optional No. 2	—	—	15.5	16.3	—	—	—	—	—
Weight with 25mm Raise (kg)		1.04	2.27	7.71	15.88	23.59	29.94	42.18	100	173
Wt per Additional 25mm Raise (kg)		0.04	0.13	0.13	0.40	0.63	0.67	1.16	1.65	2.46
Key Torque (N-m)		8.48	22.80	76.61	213.37	579.94	943.98	1374.01	2954.25	5749.55
Max Worm Speed at Full Load (rpm)	Std.	844	469	708	501	304	188	129	113	117
	Optional No. 1	—	491	378	198	169	105	72	58	83
	Optional No. 2	—	—	418	388	—	—	—	—	—
Max Load at Max Power and 1450 rpm (kN)	Std.	2.73	2.69	11.84	16.62	19.42	17.90	15.57	20.32	34.54
	Optional No. 1	—	2.21	5.34	4.93	8.40	7.74	5.52	6.61	18.01
	Optional No. 2	—	—	6.39	12.22	—	—	—	—	—

*For loads from 25% to 100% of actuator capacity, torque requirements are approximately proportional to the load.

Raises, measured in increments of 25mm, are available up to 6.1 meters, depending on lifting screw diameter and available bar stock length.

Note: Contact customer service for motorized performance.

METRIC ANTI-BACKLASH ACTUATORS

Key Adaptor Dimensions for Metric Anti-backlash Actuators

Keyed Anti-Backlash Inverted

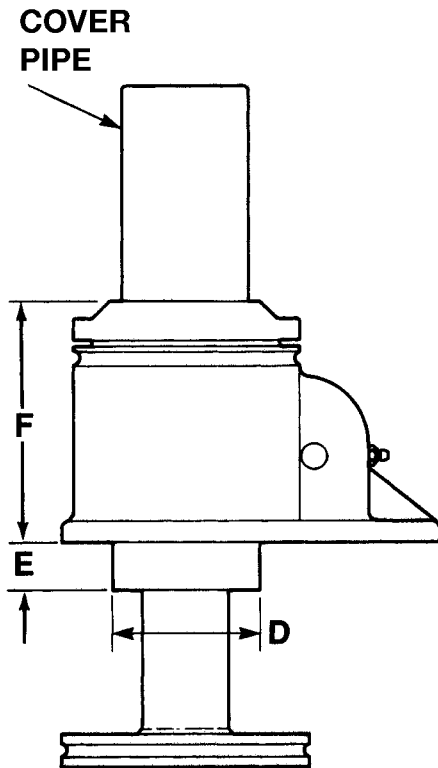

Keyed Anti-Backlash Upright

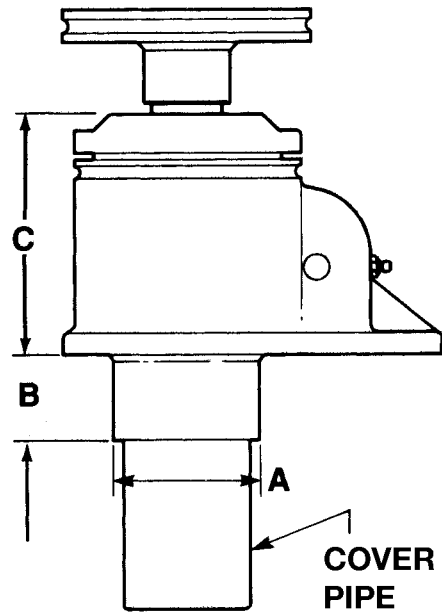

Key Adaptor Dimensions for Metric Anti-backlash Actuators

Actuator Capacity (kN)	Upright Actuators			Inverted Actuators		
	A Dia (mm)	B (mm)	C (mm)	D Dia (mm)	E (mm)	F (mm)
5	42.0	Pipe Length	64.0	31.8	20.6	73.0
10	42.0	Pipe Length	97.5	31.8	9.5	85.9
20	57.2	31.8	98.5	31.8	20.6	98.5
50	69.8	44.5	138.0	69.8	22.4	138.0
100	85.9	50.8	146.0	85.9	28.7	146.0
150	92.2	50.8	156.0	92.2	31.8	156.0
200	101.6	38.1	197.0	101.6	25.4	197.0
300	165.0	60.4	227.0	165.0	31.7	227.0
500	178.0	76.2	276.0	178.0	76.2	276.0

FREQUENTLY ASKED QUESTIONS

1. What is the lifting torque required?

The lifting torque for a single actuator depends on the load, the worm gear ratio, type of screw (machine cut or ball screw) and the pitch of the lifting screw. Torques are listed in the specification chart (pages 17, 39, 45, 50, 53 and 74) based on capacity loads. For loads from 25% to 100% of actuator model capacity, torque requirements are approximately proportional to the load.

2. Can the actuator be operated in multiple units?

Perhaps the greatest single advantage of Duff-Norton actuators is that they can be tied together mechanically, to lift and lower in unison. Typical arrangements involving the actuator units, mitre gear boxes, motors, reducers, shafting and couplings are shown on page 134.

3. How many actuators can be connected in series?

This will be limited by the input torque requirements on the first worm shaft in the line. The torque on the worm shaft of the first actuator unit should not exceed 300% of its rated full load torque based for most machine screw models.

Torque can be reduced by using a double end gear motor at the center of the arrangement or a higher capacity actuator model can be used as the first unit in the line, provided the turns for 1" raise are the same as the lower capacity units.

If this is not possible, the actuators may be individually motorized and synchronized using electronic controls.

4. Can the Duff-Norton actuator operate at high speeds?

The input horsepower to these actuators should not exceed the hp rating shown in the specifications table. Maximum RPM should not exceed 1800. We cannot accept responsibility for the overheating and rapid wear that may occur should these limits be exceeded. Horsepower increases in direct proportion to the speed, and the motor size will be out of proportion to the actuator model design rating should the speed become excessively high. When selecting the maximum permissible speed for an actuating arrangement, always check to see that the hp rating of the actuator model is not exceeded.

5. Can Duff-Norton mitre gear boxes operate at high speeds?

The gear boxes can be run at the same speeds as the actuator models. Do not exceed torque ratings.

6. What is the efficiency of the actuator?

Actuator model efficiencies are listed in the specification charts on pages 17, 39, 45, 50, 53 and 74. Where both starting and running torques are listed, use the running torque for hp calculations when using induction electric motors.

7. What is the efficiency of the mitre gear boxes?

We use 98% efficiency.

8. What is the efficiency of an actuator multiple-unit arrangement?

In addition to the efficiencies of the actuator units and the mitre gear boxes, the efficiency of the actuator multiple-unit arrangement must be taken into consideration. The arrangement efficiency allows for misalignment due to slight deformation of the structure under load, for the losses in couplings and bearings, and for a normal amount of misalignment in positioning the actuators and gear boxes. We use the following efficiencies (all standard units):

- Two Actuator Arrangement - 95%
- Three Actuator Arrangement - 90%
- Four Actuator Arrangement - 85%
- Six or Eight Actuator Arrangement - 80%

9. Can the actuator be used for continuous operation?

Recommendation should be obtained from the Duff-Norton Company on this type application and a completed application analysis form submitted. In general, semi-continuous operation can be permitted where load is light as compared to actuator model rated capacity. Units so used should be lubricated frequently and protected against dust and dirt. The Duff-Norton 7500 Series, oil-lubricated, Continuous Duty cycle actuator is designed for maximum duty cycles.

10. What is the maximum practical raise or working stroke?

Generally, standard raises are up to 12 inches on 1/4- and 1/2-Ton models and 18 inches on the 1 Ton. Maximum raises available for the larger diameter screws are limited only by the available length of bar stock from suppliers. Practical length will be affected by whether the screw is to be subjected to compression or tension loads. Depending on diameter, the length can be limited due to deformation of material in the machining process or column strength of the screw when subjected to compression loads. Long raise applications should be checked with Duff-Norton for the following:

- a) Side thrust on extended screw (see question 11)
- b) Column strength of screw (see question 12)
- c) Thermal rating of screw and nut (see question 13)

We suggest guides be used on all applications. The longer the raise, the more important this becomes.

11. Will the actuator withstand a side thrust?

Actuator units are designed primarily to raise and lower loads and any side thrust should be avoided. These units will withstand some side thrust, depending on diameter of the screw and the extended length of the screw. Where side thrusts are present, the loads should be guided and the guides, rather than the actuator units, should take the side thrust - particularly when long raises are involved. Even a small side thrust can exert great force on the housings and bearings and increase the operating torque.

12. How is the column strength of a lifting screw determined?

The column strength of a screw is determined by the relationship between the length of the screw and its diameter. A column strength nomograph is included in this book on page 100.

13. What is the cause of thermal or heat build-up in an actuator unit?

The duty cycle, the length of the screw, the magnitude of the load, and the efficiency of the actuator unit all have a direct influence on the amount of heat generated within the actuator model. Since most of the power input is used to overcome friction, a large amount of heat is generated in the worm gear set in both ball screw and machine screw actuator models, and in the lifting screw of machine screw actuator units. Long lifts can cause serious overheating.

14. What is the allowable duty cycle of a worm gear actuator?

Because of the low efficiency of worm gear actuators, the duty cycle is low at rated load. At reduced loading, the duty cycle may be increased. Consult Duff-Norton for more complete information.

15. What is the life of the worm gear actuator?

The life of a machine screw actuator screw, nut and worm gear set varies considerably due to extent of lubrication, abrasive or chemical action, overloading, eccentric loading, excessive heat, improper maintenance, etc.

16. Can the actuator be used to pivot a load?

Yes, although the Duff-Norton SuperCylinder is recommended for these applications due to stroke limitations with the conventional double clevis configuration. Double clevis actuators are furnished with a clevis at both ends. The bottom clevis is welded to the bottom end of an extra strong pipe which is threaded into the base of the actuator and welded. This bottom pipe still performs its primary function of encasing the lifting screw in its retracted position. The design of the structure in which this type unit is to be used must be so constructed that the actuator unit can pivot at both ends. Use only direct compression or tension loads, thereby eliminating side thrust conditions. See the double clevis model illustrations on the dimensional drawings.

17. Can the actuator unit be used within rigid structures or presses?

We recommend that the actuator selected have a greater capacity than the rated capacity of the press or of the load capacity of the structure. We also recommend that a torque limiting clutch or similar device be used to prevent overloading of the actuator unit. Unless these precautions are taken, it is possible to overload the actuator unit without realizing it, because it is difficult to determine just what load is being imposed on the actuator unit.

FREQUENTLY ASKED QUESTIONS

18. Can the lifting screw be keyed to prevent rotation?

Yes, except for the ball screw (where we use a square nut on the end of the screw and a square tube to prevent screw rotation); however, the keyway in the screw causes greater than normal wear on the internal threads of the worm gear. The ball screw cannot be keyed, as the keyway would interrupt the ball track, permitting loss of the recirculating balls. We also recommend the following methods for preventing rotation. For multiple actuator model applications, bolt the lifting screw top plates to the member being lifted. For single actuator unit applications, bolt the lifting screw top plate to the load. And the load should be guided to prevent rotation.

19. Why is it ever necessary to use a keyed lifting screw?

When an actuator unit is operated, the rotation of the worm shaft causes the worm gear to rotate. The worm gear is threaded to accommodate the lifting screw thread; as the worm gear turns, the friction forces on the screw thread act to turn the screw also. The greater the load on the actuator unit, the greater the tendency of the screw to turn. It is obvious that if the screw turns with the nut (worm gear), it will not raise the load. In those cases where a single unit is used, and where the load cannot be restrained from turning, it is necessary to key the lifting screw. The lifting screw turning movement or key torque is shown on pages 17, 39, 45, 50, 53 and 74.

20. Can an actuator model with an inverted lifting screw be keyed?

Yes, but the key is mounted in the shell cap, making it necessary to omit the dust guard as a standard item. If a dust guard is required, a special adaptor must be attached to permit mounting.

21. Can bellows boots be supplied for an actuator model with inverted screw?

Yes, but allowance must be made in the length of the lifting screw for both the closed height of the boot and structure thickness. Since we can make no provision for attaching a boot on the underside of your structure, we suggest that a circular plate similar to the lifting screw top plate be welded or bolted to the bottom of your structure supporting the actuator unit, thereby making it possible to use a standard bellows boot. (See pages 146-147.)

22. Can stop discs, stop pins or stop nuts be used on the actuator unit?

Stop disc, pins or nuts can be recommended on the actuator unit that is hand operated. For motor driven units, the full capacity of the actuator unit or even a greater force (depending on the power of the motor) can be applied against the stop, thereby jamming so tightly it must be disassembled in order to free it. It is suggested that external stops be used where possible. Under ideal conditions where a slip clutch or torque limiting device is used, a stop pin or stop nut may be used - but the Duff-Norton Company should be consulted. The stop disc used on the bottom of the lifting screw in our ball screw units are not power stops. These are used to ensure that the lifting screw will not run out of the ball nut during shipping and handling, thereby permitting loss of the recirculating balls.

23. Will the actuator withstand shock loads?

Shock loads should be eliminated or reduced as much as possible, but if they cannot be avoided, the actuator model selected should be rated at twice the required static load. For severe shock load applications, using machine screw models, the load bearings should be replaced with heat-treated steel thrust rings which will increase the lifting torque approximately 100 percent. These rings are available as a special from Duff-Norton.

24. Is the actuator self - locking?

Only machine screw and anti-backlash models with 24:1 and 25:1 ratios are self-locking in most cases. Other machine screw and anti-backlash models with 12:1 lower ratios are not self-locking. All ball screw models are not self-locking. Units considered not self-locking will require a brake or other control device. If vibration conditions exist, see question 25.

25. Can the actuator unit be used where vibration is present?

Yes, but vibration can cause the lifting screw to creep or inch down under load. For applications involving slight vibration, select the higher of the worm gear ratios. Should considerable vibration be present, use a drive motor equipped with a magnetic brake which will prevent the actuator model from self-lowering.

26. Will the actuator unit drift after the motor is switched off?

Yes, unless a brake of sufficient capacity is used to prevent it. The amount of drift will depend upon the load on the actuator unit and the inertia of the rotor in the motor. Most Machine Screw models require approximately one-half as much torque to lower the load as it does to raise the load.

For the machine screw actuator unit with no load, the amount of drift will depend upon the size and speed of the motor. For example, a 1750 RPM motor directly connected to an actuator unit (without a load) will give on the average 2" - 3" drift; a 500 RPM gear motor will give about 1/9 as much drift. Note that the drift varies as the square of the velocity (RPM). The drift of the actuator unit screw can be controlled by using a magnetic brake on the motor.

27. Is the torque of a rotating screw actuator unit the same as a standard unit?

The lifting torque, as well as the efficiency and side thrust ratings, are the same for a rotating screw unit. It is understood, however, that the same pitch and screw diameter are used in each actuator unit, as well as the same worm gear ratio. This comment also applies to the inverted actuator unit and those with threaded or clevis-style ends.

28. Is the worm gear actuator unit suitable for high temperature operation?

The actuator is normally suitable for operation at ambient temperatures of up to 200°F using standard greases and seals. Operation above 200°F will require special lubricants. For temperatures above 300°F the life of even special lubricants is limited in direct proportion to increase in temperature and duration of exposure to such temperatures. At 400°F and above, the oil in the grease will vaporize and grease will carbonize and solidify. Applications of this type should be avoided. For temperatures above 250°F advise Duff-Norton of full particulars of the duration of such temperatures. In some cases, it may be necessary to furnish unlubricated units, then the customer will supply the lubricant of his own choice. We suggest that a lubricant manufacturer be consulted for type of grease and lubrication schedule. As a general rule, the actuator unit should be shielded to keep ambient temperatures to 200°F or less.

Seals for temperatures above 250°F are very expensive. Instead, we would substitute bronze bushings for seals in these cases. If bellows boots are used, special materials will be required for temperatures above 200°F

28a. Is the actuator unit suitable for low temperature operation?

With the standard lubricant and materials of construction, the actuator is suitable for use at sustained temperatures of 0°F. Below 0°F, low temperature lubricant should be used. Also, at temperatures below 0°F, if there is any possibility of shock loading, special materials may be required due to notch sensitivity of the standard materials at lower temperatures. Duff-Norton factory application engineers must be consulted in these instances for a recommendation.

Actuators with standard materials of construction and lubrication may be safely stored at temperatures as low as -65°F.

29. How much backlash is there in the actuator unit?

The machine screw, anti-backlash and Ball Screw models must be considered separately, as the normal backlash will vary due to different constructions.

For the machine screw models there is a normal backlash of .005" to .008" in the lifting screw thread, plus .002" to .003" backlash in the load bearings. Therefore, the total backlash is .007" to .011". This backlash is due not only to normal manufacturing tolerances, but to the fact that we must have some clearances to prevent binding and galling when the actuator unit is under load. Usually, the backlash is not a problem unless the load on the actuator unit changes between compression and tension. If a problem does exist, then an anti-backlash model should be considered.

anti-backlash models: This unit can be adjusted for screw thread and bearing clearances to a minimum of .0005". Some clearances must be maintained to keep torque requirements within reason. As the inside thread of the worm gear and the anti-backlash nut wears, adjustment can be maintained by tightening down on the shell cap. Setscrews located in the top of the shell cap are to be resotted each time an adjustment is made.

The additional nut used in the anti-backlash actuator unit is a built-in wear indicator. The clearance between the two nuts is designed to be 50 percent of the thread thickness. When all this adjustment is used, it indicates the point where the worm gear and the anti-backlash nut set is to be replaced. See the illustration of this feature on page 40.

Ball screw models will have a normal backlash of .002" to .013" between the ball nut and the ball track; .002" to .003" backlash in the load bearings. Total backlash will be .004" to .016". As machine screw models, this backlash will not be detrimental unless the load changes between compression and tension, or tension and compression.

FREQUENTLY ASKED QUESTIONS

30. How does the “Anti-Backlash” feature operate?

The worm gear and the anti-backlash nut are pinned together with guide pins. The threads in the anti-backlash nut work in opposition to the worm gear on the threads of the lifting screw.

Adjustment is made by threading in the shell cap of the actuator unit, which forces the anti-backlash nut threads into closer contact, reducing clearance and thus reducing backlash. (See page 46)

31. What lead error is present in the lifting screw threads?

Machine screw and anti-backlash model lift screws may have lead error up to .0008 per inch. It is cumulative and not detrimental to the operation of the actuator model.

Ball screw models use heat treated rolled ball track with a lead error up to .003 per inch.

32. How do you compute the raise per minute with a given worm shaft speed?

When the worm shaft speed is known, the distance the load can be raised per minute can be determined with this formula:

$$\text{Raise per minute} = \frac{\text{RPM of Worm Shaft}}{\text{Turns of worm for 1" raise}}$$

or Travel per Worm Turn (mm) x RPM of Worm Shaft (Worm turns for 1" raise are shown in actuator specifications on pages 17, 39, 45, 50, 53 and 74).

33. How do you calculate the RPM of worm shaft necessary to achieve a given rate of raise?

If the application calls for a certain raise per minute, the worm shaft speed which will give the rate of raise can be calculated as follows (or see tables on pages 108 thru 112).

$$\text{Worm shaft RPM} = \frac{\text{Desired Rate of Raise (in/min)}}{\text{Worm Turns for 1" Raise}}$$

For metric actuators:

$$\text{RPM} = \frac{\text{Desired Rate of Raise (mm/min)}}{\text{Travel per worm Turn (mm)}}$$

34. How is the Duff - Norton rotary limit switch mounted on an actuator unit?

It is suggested that the actuator unit be purchased with the limit switch factory mounted. The rotary limit switch can be field mounted by following the instructions found in this book under “Rotary Limit Switch.” In most cases, the switch is mounted to the worm using the worm flange retainer bolts. This switch cannot be directly mounted on 1/4 to 1-Ton actuator models.

35. How is the maximum raise determined when using the limit switch?

Maximum raise is determined by the ratio of the switch used and the turns for one inch raise of the actuator unit. The limit switch ratios available are 10:1, 20:1 and 40:1. Refer to the charts on pages 124-125 or on the inside cover of the limit switch, and use the following formula.

$$\text{Max. Raise of Actuator Unit (inches)} = \text{Max. Input Revolutions of Limit Switch} \times \text{Turns of Actuator Unit Worm for 1" raise}$$

36. How is the rotary limit switch adjusted for position stop?

The Duff-Norton rotary limit switch is infinitesimally adjustable by moving the adjustable nuts of the worm driven screw.

37. Can a multiple actuator unit arrangement be set up to visually indicate position of the lifting screw at any given point?

Yes, in several ways. However, it is suggested you consult the Duff-Norton Company for recommendations based on your particular application.

Flange Bolt Information

Refer to respective catalog dimensional drawings for orientation on flange bolts in relation to the horizontal ϕ for 4-hole pattern and 30° to horizontal ϕ for 6-hole pattern.



Worm Flange

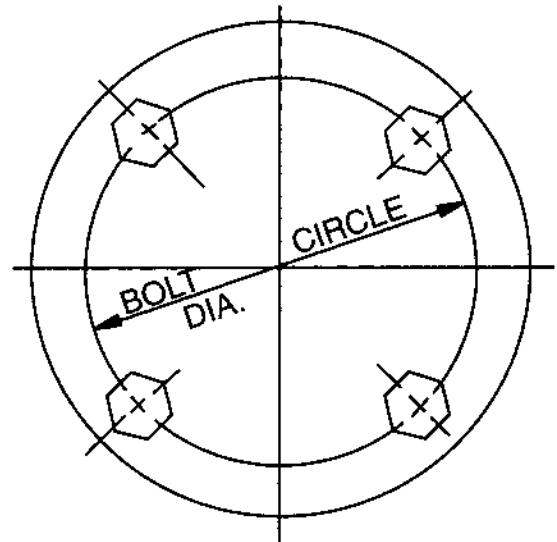

Flange Bolt Information

Actuator Rating	B.C. Diameter	Bolt Information
1/4 Ton	NA	No Flange Bolts
1/2 Ton	NA	No Flange Bolts
1 Ton	NA	No Flange Bolts
2 Ton	1 11/16"	Four 1/4-20 x 3/4" Lg. Eq. Spaced @ 90 degrees
3 Ton BS	1 11/16"	Four 1/4-20 x 3/4" Lg. Eq. Spaced @ 90 degrees
3 Ton MS	2 3/32"	Four 1/4-20 x 3/4" Lg. Eq. Spaced @ 90 degrees
5 Ton	2 3/8"	Four 5/16-18 x 3/4" Lg. Eq. Spaced @ 90 degrees
10 Ton	3"	Four 5/16-18 x 3/4" Lg. Eq. Spaced @ 90 degrees
15 Ton	2 3/4"	Four 5/16-18 x 1" Lg. Eq. Spaced @ 90 degrees
20 Ton	3 1/2"	Four 3/8-16 x 1" Lg. Eq. Spaced @ 90 degrees
25 Ton	4 1/8"	Four 3/8-16 x 1 1/4" Lg. Eq. Spaced @ 90 degrees
35 Ton	4 1/4"	Four 1/2-13 x 1 1/4" Lg. Eq. Spaced @ 90 degrees
50 Ton	5 1/4"	Four 5/8-11 x 1 1/2" Lg. Eq. Spaced @ 90 degrees
75 Ton	5 3/4"	Six 5/8-11 x 1 1/2" Lg. Eq. Spaced @ 60 degrees
100 Ton	6 1/4"	Six 5/8-11 x 1 1/2" Lg. Eq. Spaced @ 60 degrees
150 Ton	6 1/4"	Six 5/8-11 x 1 1/2" Lg. Eq. Spaced @ 60 degrees
250 Ton	8 1/4"	Six 3/4-10 x 2" Lg. Eq. Spaced @ 60 degrees

Overhung Load Capacity of Actuator Worm Shaft (lbs.)

Actuator	Overhung Load
1/4 Ton MS	50
1/2 Ton MS	45
1/2 Ton BS	45
1 Ton MS & BS	55
2 Ton MS & BS	30
3 Ton MS	60
3 Ton BS	120
5 Ton MS&BS	105
10 Ton MS & BS	305
15 Ton MS	390
20 Ton MS & BS	325
25 Ton MS & BS	735
35 Ton MS	665
50 Ton MS & BS	350
75 Ton MS	630
100 Ton MS	650
150 Ton MS	350
250 Ton MS	1310

Note:

1. These ratings are based on use of roller chain and sprocket. For other conditions, divide ratings by following factors (must include bolt tension or gear separating forces):
 - 1.25 for overhung gear
 - 1.50 for overhung "V" belt
 - 2.50 for overhung flat belt
2. Ratings are based on standard actuator model worm shaft extensions and are calculated on the basis of concentrated load applied at a point 1/2 the keyway length measured from extreme end of worm shaft.
3. Above ratings apply to actuators carrying any load up to their rated capacity.



Machine Screw Actuators Loads and Raises

Raise (In.)	1/4 Ton	1/2 Ton	1 Ton	2 Ton	3 Ton	5 Ton	10 Ton	15 Ton	20 Ton	25 Ton	35 Ton	50 Ton	75 Ton	100 Ton	150 Ton	250 Ton
3	.040	.050	.020	.020	.020	.030	.025	.030	.025	.035	.040	.060	.050	.050	.050	.090
6	.085	.075	.030	.035	.035	.050	.040	.045	.040	.060	.050	.090	.060	.060	.060	.100
9	.090	.105	.040	.055	.055	.070	.055	.065	.050	.085	.060	.120	.070	.070	.070	.110
12	.115	.135	.050	.070	.070	.090	.070	.080	.070	.105	.070	.150	.080	.080	.080	.120
15	.140	.165	.060	.090	.090	.110	.085	.100	.080	.130	.080	.180	.090	.090	.090	.130
18	.165	.195	.070	.100	.100	.1030	.100	.120	.095	.155	.090	.215	.100	.100	.100	.140
21	.190	.225	.080	.120	.120	.150	.115	.133	.105	.175	.100	.245	.110	.110	.110	.150
24	.215	.255	.090	.135	.130	.170	.135	.150	.125	.200	.110	.275	.120	.120	.120	.160

Notes:

1. Does not allow for possible deflection due to side thrust.
2. Lateral movements are for information only. For best results, we suggest guides where possible.
3. The above movements apply to machine screw actuator models only and not to the ball screw series.

Permitting lateral movement on the ball screw under load will exert side thrust on the ball screw and ball nut, and will be detrimental to ball screw and ball screw nut life. Ball screw applications should be guided to ensure a minimum of lateral movement.

Worm Rotation Chart

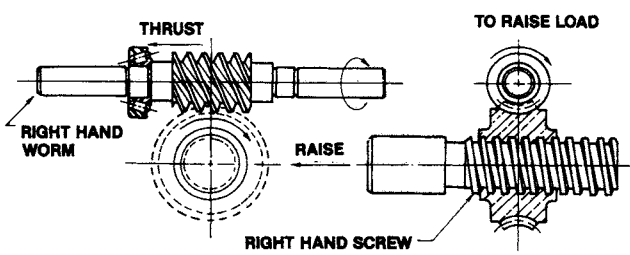
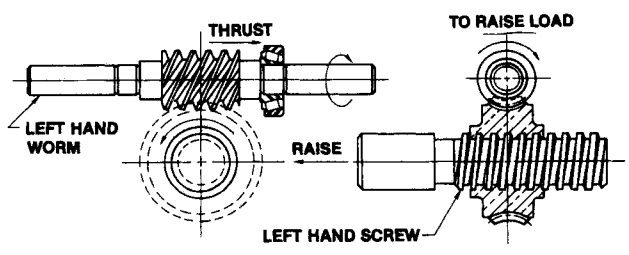
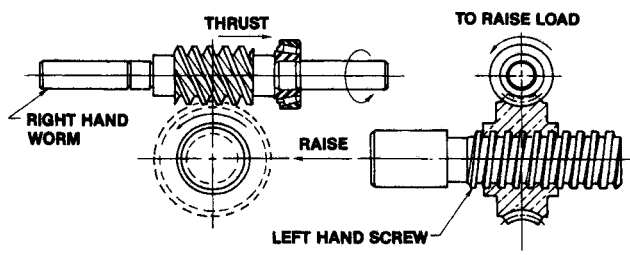
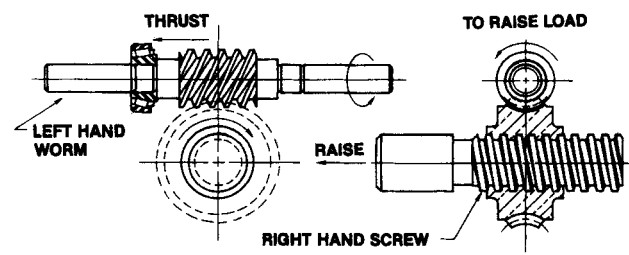
 <p>Standard for All Except 50 and 75 ton MS, 50 ton BS</p> <p>Clockwise Rotation of Worm Raises Load</p>	 <p>Standard for 1850, 9050 & 9075 Except 50 and 75 ton MS, 50 ton BS Special for all Orther Actuators Unit at Extra Cost</p> <p>Clockwise Rotation of Worm Raises Load</p>
 <p>Special for all Actuator Units</p> <p>Counter-Clockwise Rotation of Worm Raises Load</p>	 <p>Standard for 50 ton BS Special for all Other Actuators Units at Extra Cost</p> <p>Counter-Clockwise Rotation of Worm Raises Load</p>

Load Screw Column Strength Specifications

Machine Screw

Capacity	Max. Permissible Screw Length Regardless of Load (in.)		Max. Pin-to-Pin Length Pinned Ends
	Fixed Free	Fixed Guided	
1/4 Ton MS	9	24	19
1/2 Ton MS	11	30	24
1 Ton MS	12	33	26
2 Ton MS	17	45	36
3 Ton MS	17	45	36
5 Ton MS	24	64	51
10 Ton MS	33	85	68
15 Ton MS	38	100	80
20 Ton MS	44	116	93
25 Ton MS	58	154	123
35 Ton MS	79	207	166
50 Ton MS	98	256	205
75 Ton MS	104	273	219
100 Ton MS	122	320	256
150 Ton MS	147	386	309
250 Ton MS	187	492	393

Ball Screw

Capacity	Max. Permissible Screw Length Regardless of Load (in.)		Max. Pin-to-Pin Length Pinned Ends
	Fixed Free	Fixed Guided	
1/2 Ton BS	11	30	24
1 Ton BS	15	41	33
2 Ton BS	20	51	41
3 Ton BS	21	54	44
5 Ton BS	27	71	57
10 Ton BS	27	71	57
20 Ton BS	44	116	93
25 Ton BS	59	155	124
50 Ton BS	80	211	169

Continuous Duty

Capacity	Max. Permissible Screw Length Regardless of Load (in.)		Max. Pin-to-Pin Length Pinned Ends
	Fixed Free	Fixed Guided	
7511 CD	21	54	44
7515 CD	27	71	57
7522 CD	44	116	93

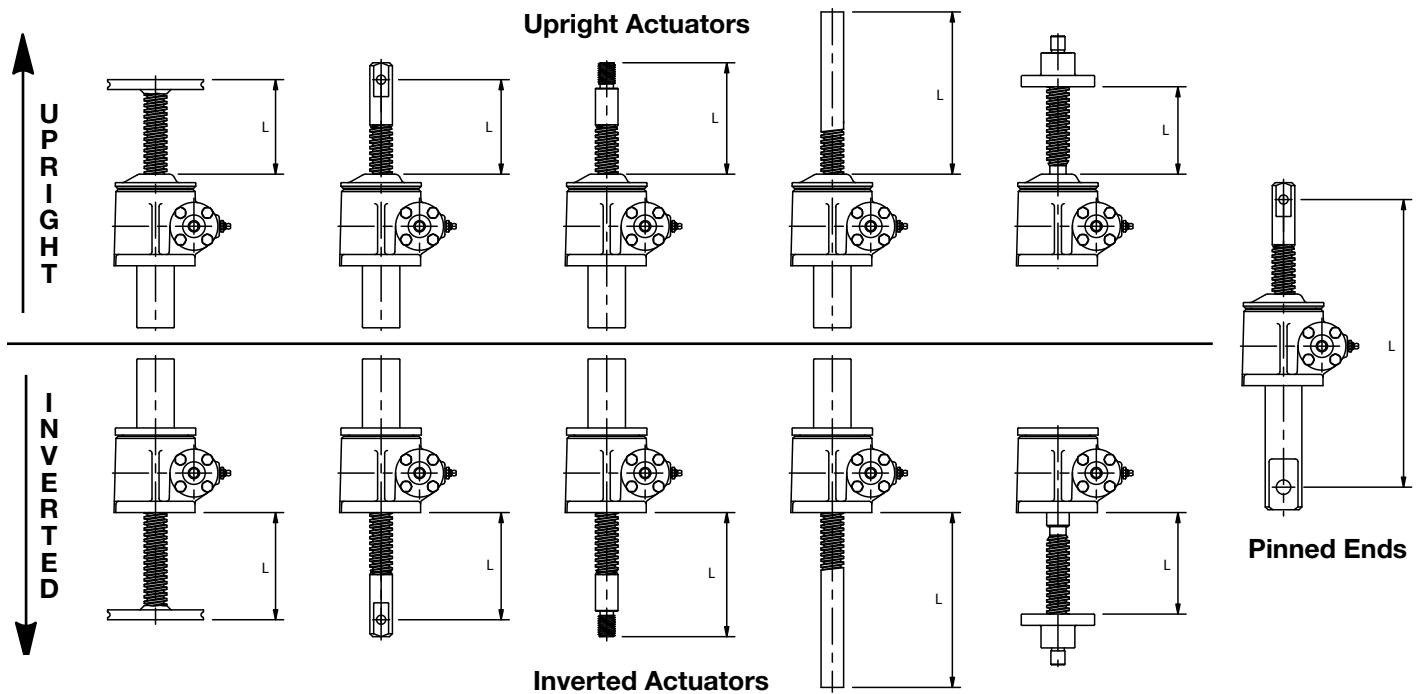

Screw Length - Screw lengths for strength curves are defined as shown.

Note: Screw length can be converted to actuator raise or actuator raise can be converted to screw length by use of appropriate dimensional diagrams in the design guide for standard actuator models or special dimensions and dimensional diagrams for special actuator models.

Caution: Actual loads on any actuator should never exceed catalog load rating for that actuator.

Safety Factor - The loads on the vertical axis for the strength curves are theoretical buckling loads as predicted by the Euler column formula in sloping portions and twice rated actuator loads in the horizontal portions. See AISC or other applicable codes for selecting appropriate safety factors.

Load Screw Column Strength Specifications

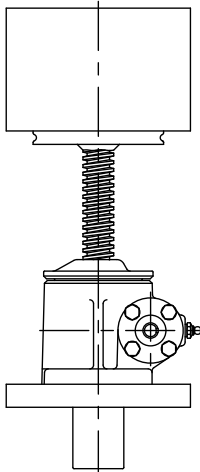

**One end fixed,
one end free**

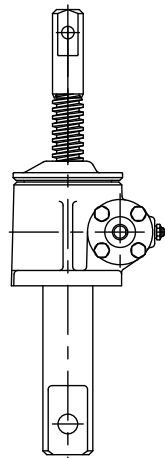

Pinned Ends

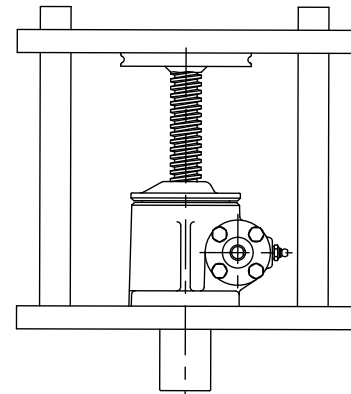

**One end fixed,
one end guided**

End Fixity Conditions - The horizontal axis of the strength curves has three screw length scales. The top scale is for the housing end of the screw fixed and the load end of the screw free from guiding. The middle scale is for trunnion or pin mounted actuators. The bottom scale is for the housing end of the screw fixed and the load end of the screw guided. Duff-Norton recommends that load end of actuator screws be guided so that forced misalignment does not occur.

Maximum Permissible Screw Length - The strength curves terminate at a screw length where the screw slenderness ratio is 200. Maximum length versus actuator model is tabulated in the right portion of this page. Screw lengths longer than shown are not recommended regardless of load.

Steps To Follow - To select an actuator suitable for a specific load at a specific screw length with specific end fixity conditions.

1. Select safety factor from AISC or other applicable codes suitable for actuator application.
2. Multiply load by safety factor to determine failure load.
3. Locate failure load on vertical axis.
4. Locate screw length on appropriate horizontal axis.
5. Project horizontally right from failure load and vertically up from screw length to where projections intersect.
6. Any actuator with its curve above the intersection is suitable for the application provided that the actuator's load rating and its maximum permissible screw length are not exceeded.

Example - Select a standard upright clevis end machine screw actuator for a 14,000 lb. unguided load and a 25 in. raise. For first approximation assume screw length equal raise.

1. Select safety factor. For example 1.92 from AISC specifications.
2. Multiply 14,000 lb. load by 1.92 safety factor to obtain 26,880 lb. failure load.
3. Locate 26,880 lb. load on vertical axis.
4. Locate 25 in. screw length on upper horizontal axis scale.
5. Project horizontally right from 26,880 lb. load and vertically up from 25 in. screw length.
6. Select 9015 actuator since its strength curve is above the intersection, the 14,000 lb. load is less than the 30,000 lb. rated load and the 25 in. screw length is less than the 41 in. maximum permissible screw length.

Recheck actuator selection using true screw length. Convert 25 in. actuator raise to true screw length.

8.50 in.	"A" dimension for clevis typescrew end from screw end dimension diagram.
-6.31 in.	Mounting face to top of shell cap from 9015 dimensional diagram.
2.19 in.	Screw length at no raise.
+ 25.00 in.	Raise.
27.19 in.	True screw length at 25 in. raise.

Use failure load of 26,880 lb. and true screw length of 27.19 in. and re-enter chart to verify that 9015 is a safe selection.

Screw Column Strength Chart

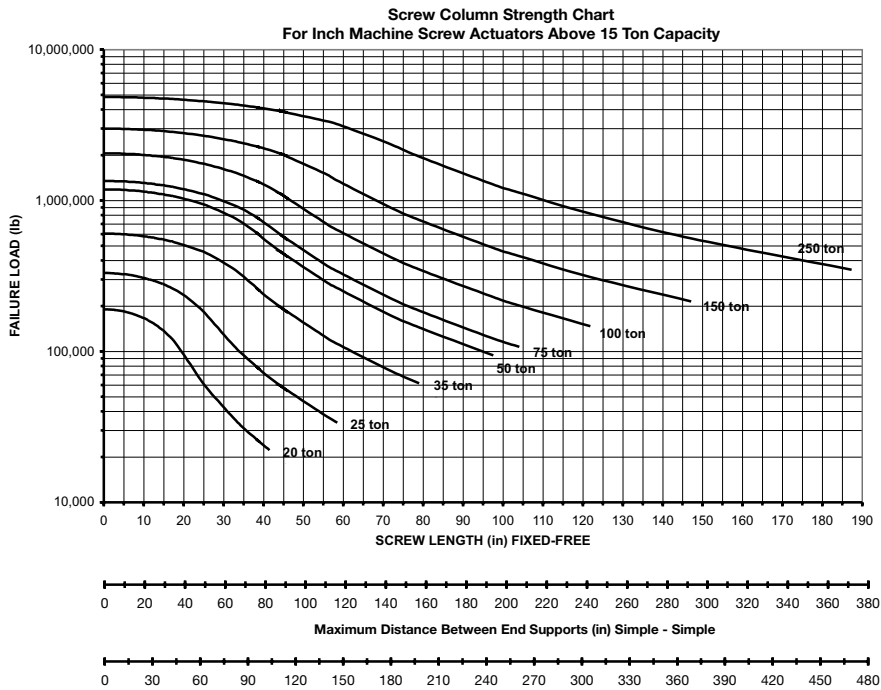
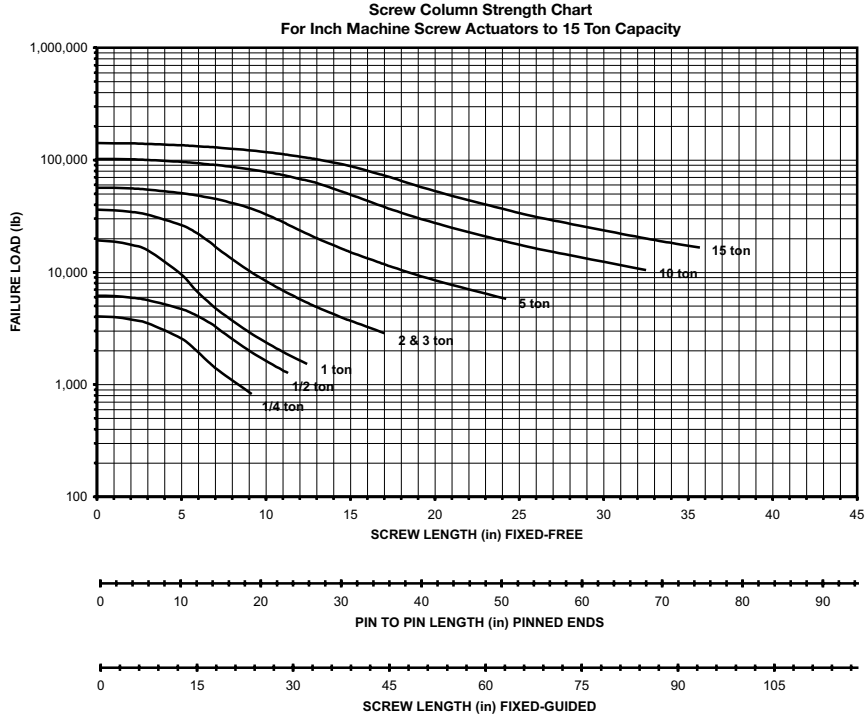

Screw Column Strength Chart

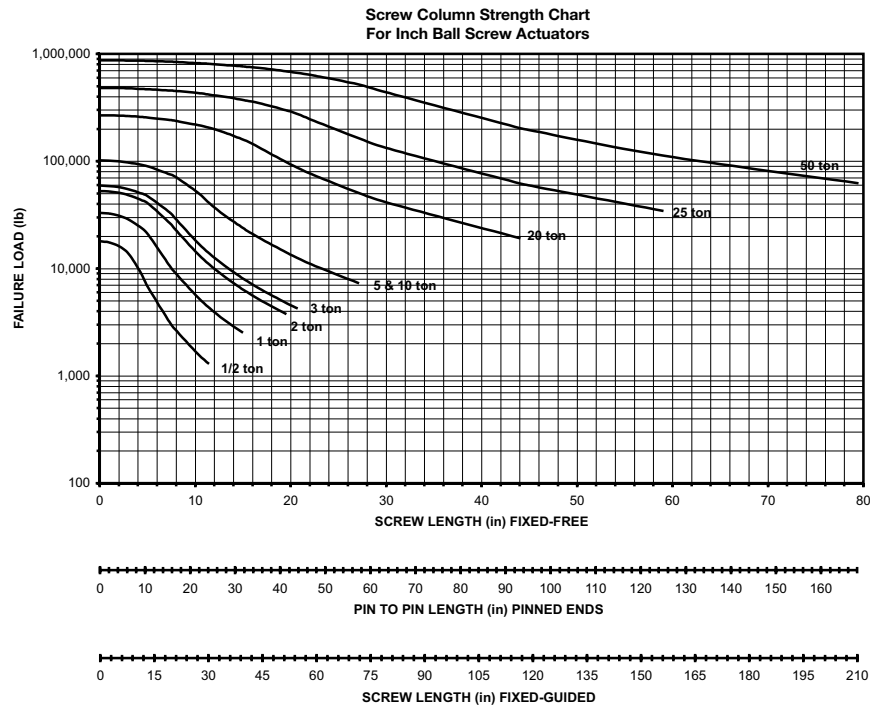
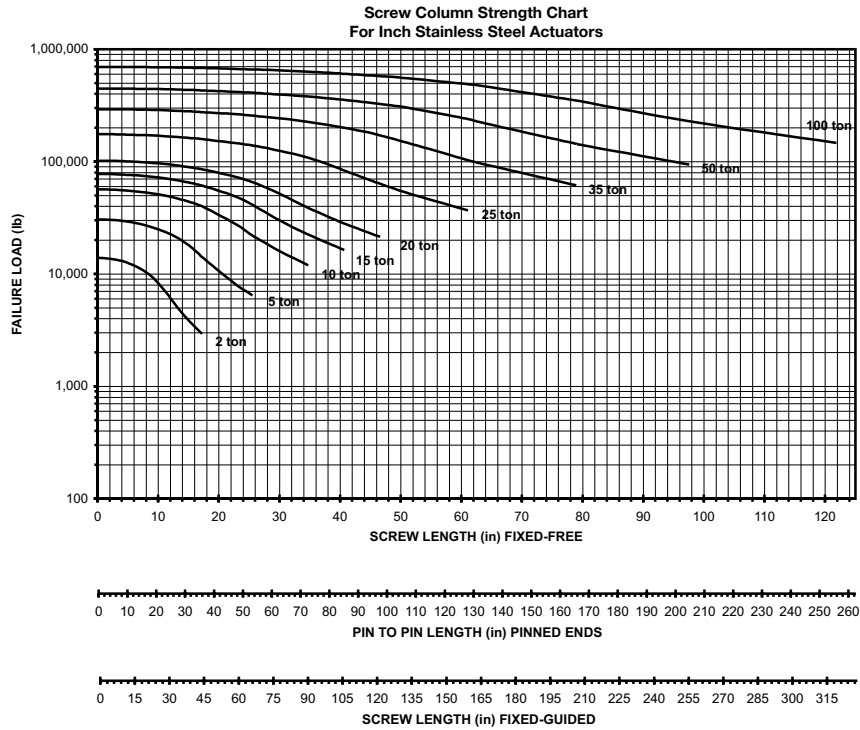

Screw Column Strength Chart

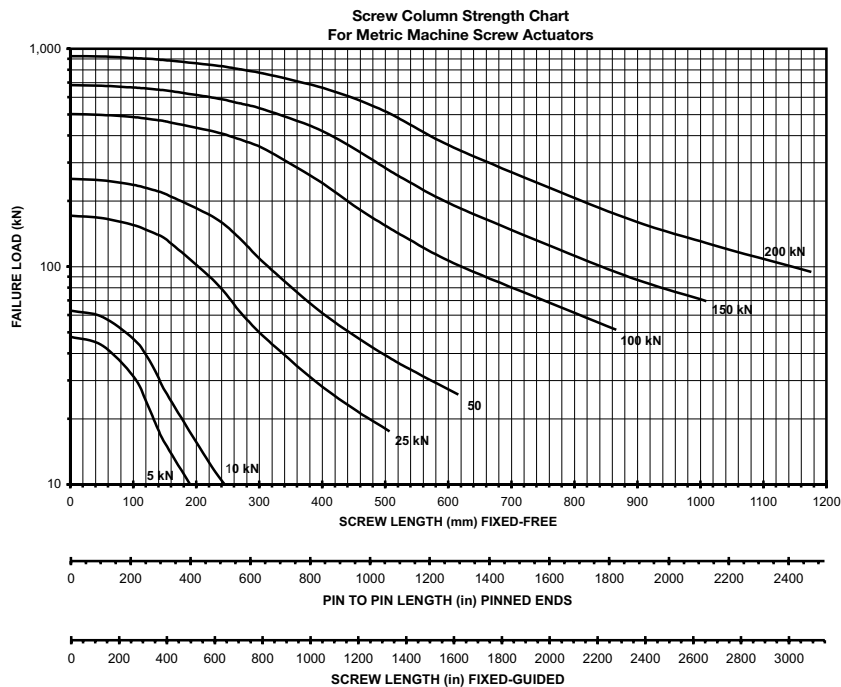
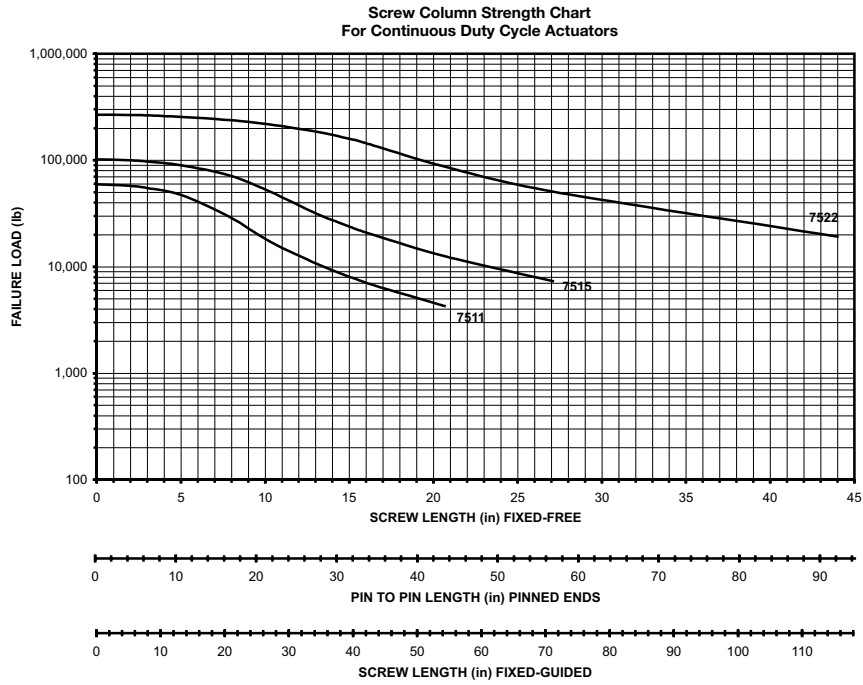

Ball Screw and Nut Life Rating

Predicting screw and nut life lets you forecast necessary replacement, saving time and money. It also permits selection of the most economical screw size.

Use caution when installing the ball screw. The life expectancy listed below may be greatly reduced if ball screws are subjected to misalignment, shock loads, side thrust, environmental contamination or lack of lubrication and maintenance.

It is possible to estimate the minimum life of the Duff-Norton ball screw and nut only. Because of the many variable operating conditions, we can not predict the life of the worm and gear set in the ball screw actuators.

*5 ton and 10 ton models use the same screw and nut.

Ball Screw Actuator Life Expectancy (total in. of travel)

Capacity (Tons)	100% of Full Load	75% of Full Load	50% of Full Load
1/2	470,000	1,100,000	3,700,000
1	110,000	250,000	860,000
2	65,000	150,000	520,000
2 - High Lead	150,000	360,000	1,200,000
3	210,000	650,000	2,200,000
5	1,000,000	2,400,000	8,100,000
5 - High Lead	440,000	1,000,000	3,500,000
10	130,000	300,000	1,000,000
10 High Lead	50,000	130,000	430,000
20	150,000	360,000	1,200,000
25	700,000	1,600,000	5,600,000
50	630,000	1,500,000	5,000,000

Continuous Duty Actuator Life Expectancy (total in. of travel)

Model No.	1 Max. Cap.	0.75 Max. Cap.	0.5 Max. Cap.	0.25 Max. Cap.	0.1 Max. Cap.
7511	1.10	2.70	9.50	60.00	150.00
7515	.44	1.00	3.70	34.00	110.00
7522	.64	1.50	5.50	50.00	130.00
Max. Allow. Duty Cycle @ 1750 RPM Input	33%	67%	100%	100%	100%

Note: Duty Cycles are based on a 100°F temp. rise not to exceed 200°F using Duff-Norton's standard oil.

*Life expectancies listed are L₁₀ values - values where 10% of screw can, statistically, be expected to fail.

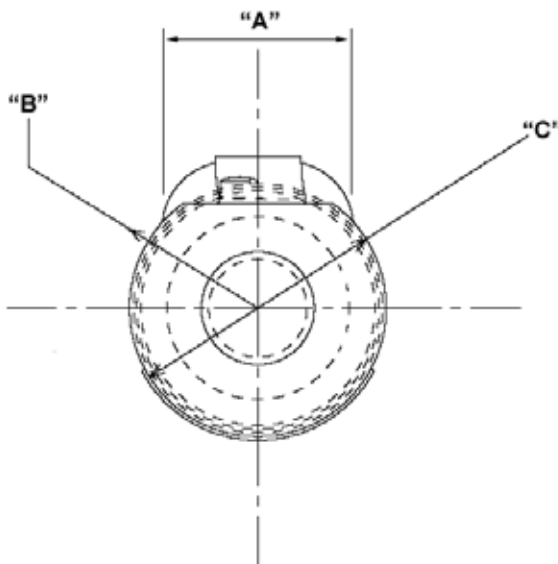

Ball Nut Dimensions

Capacity (Tons)	"A"	"B" Radius	"C"
1/2	.822	.797	1.000 Sq.
1	.812	.875	1.250 Sq.
2	1.104	1.194	1.500 Sq.
2 - High Lead	1.104	1.194	1.500 Sq.
3	1.587	1.386	2.125 Dia.
5	1.981	1.690	2.625 Dia.
5 - High Lead	1.718	1.720	2.625 Dia.
10	1.981	1.690	2.625 Dia.
10 High Lead	1.718	1.720	2.625 Dia.
20	2.561	2.272	3.375 Dia.
25	3.349	3.076	4.751 Dia.
50	4.029	3.756	5.990 Dia.

POWERED ACTUATORS



All actuators require an external power source. Whether this power source be an electric motor or hand wheel Duff-Norton has the required component.

Customers who choose to power their actuators with an electric motor may do so by connecting the motor to the actuator via a C-face adapter, right angle gear reducer, or by remotely connecting the motor and actuator worm shaft with a coupling and connecting shaft.

Some customers opt to manually power their actuators. In those cases hand wheels are usually the preferred drive component.

Gear Reducer Driven

Duff-Norton provides customers with the most comprehensive and easily implemented motorized gear reducer assortment. For the first time customers can easily select the gear reducer model best suited for their application.

Features

- Available on 2 Ton through 50 Ton, machine screw or ball screw actuators
- Largest selection of gear reducer ratios available
- Easy mounting simplifies installation, eliminates drive alignment problems
- Field retrofit possible on most existing non-motorized models
- Modular assembly allows many different arrangements. Most models can have parts repositioned in the field to solve clearance problems
- Properly sized motor and gear reducer mounted directly to side of actuator (see pgs. 140-143 for shafts & couplings, etc.)
- One motorized actuator can shaft drive one or more additional actuators
- Reducer's aluminum and finned housings yield better cooling properties
- Eliminates exposed shafts and couplings; no need to design and source shafts or couplings
- 1725 rpm, 230/460 volt, 3 phase TEFC motors standard. Other voltages and special motor features available

How to size a Motorized Gear Reducer

Determine whether machine screw or ball screw actuators are to be used. Determine if it is a single actuator application, or multiple actuators, shaft driven from a common motorized reducer.

For a single actuator:

1. Determine actuator load.
2. Refer to the tables on pages 108-112. Select an actuator model with adequate nominal load rating. Ratings larger than actual load may be required due to column strength, life requirements, etc.
3. Select a reducer ratio to provide a suitable lifting speed.
4. Go along that line of the table to find a load capacity equal to or greater than applied load. Note the motor horsepower from the top of the column.

Note: Ratings in the shaded area of the chart exceed the safe load rating of a single actuator and are shown for designing multiple actuator systems. In no case should an actuator be used at a higher load or input horsepower than shown in the actuator specification charts on pages 17, 39, 45, 50, 53 and 74.



For multiple actuators, shaft driven from a single reducer:

1. Determine total system load and distribution of load between actuators.
2. Refer to the tables on pages 108-112. Select an actuator model with nominal load rating adequate for the most heavily loaded actuator in the system.
3. Select a reducer ratio to provide a suitable lifting speed.
4. Go along that line of the table to find a load capacity equal to or greater than total system load. Note the motor horsepower from the top of the column.

POWERED ACTUATORS

Machine Screw Actuators - Performance Specifications

The gear reducers shown in this section are sized with adequate power ratings to allow a single actuator to be used at its full load or horsepower rating. For multiple actuator applications, the reducers shown may not provide adequate power to operate several actuators at full rating. Oversized reducers are available. Contact Duff-Norton Customer Service for multiple actuator applications if the total capacity is greater than shown.

Actuator Model	Actuator Ratio	Reducer Model	Reducer Ratio	Lifting Speed (in/min)	Lifting Capacity (pounds) - See Notes Below															
					Motor Horsepower(1725rpm) / Frame Size															
					1/4 - 56C	1/3 - 56C	1/2 - 56C	3/4 - 56C	1 - 56C	1.5 - 140TC	2 - 140TC	3 - 180TC	5 - 180TC	7.5 - 180TC						
2 Ton MS	6:1	31	5	14.4	1320	1750	2650	3980	5300								Note:180TC flange!			
			7.5	9.6	1900	2500	3800	5720	7620											
			10	7.2	2430	3200	4860													
			15	4.8	3290	4340	6500													
			20	3.6	4120	5440	8200													
			25	2.9	4900	6490														
			30	2.4	5100	6740														
3 Ton MS	6:1	40	5	14.4	1450	1930	2900	4350	5800	8700	11600									
			7.5	9.6	2080	2770	4160	6250	8330	12500										
			10	7.2	2725	3630	5450	8175	10900											
			15	4.8	3725	4960	7450	11200	14900											
			20	3.6	4700	6260	9400	14100												
			25	2.9	5650	7500	11300													
			30	2.4	6000	8000	12000													
5 Ton MS	6:1	50	5	21.9	925	1230	1850	2775	3700	5550	7400	11100						Note: Model 50 reducer requires 140 Frame motor for 3HP application		
			7.5	14.5	1340	1780	2680	4010	5350	8020	10700	16090								
			10	10.9	1750	2330	3500	5250	7000	10500	14000									
			15	7.3	2425	3230	4850	7270	9700	14500	18000									
			20	5.5	3100	4140	6220	9320	12430	18000										
			25	4.4	3750	5000	7500	11260	15000											
			30	3.6	4040	5400	8090	12100	16200											
10 Ton MS	8:1	63	5	21.9	1120	1500	2240	3360	4480	6720	8960	13400	22400							
			7.5	14.5	1650	2200	3300	4940	6600	10000	13200	19800	33700							
			10	10.9	2150	2860	4290	6430	8580	12860	17150	25730								
			15	7.3	3025	4030	6050	9070	12090	18100	24180	36200								
			20	5.5	3880	5175	7760	11640	15520	23300	31000									
			25	4.4	4700	6260	9400	14100	18800	28200	37600									
			30	3.6	5150	6860	10300	15450	20600	30900	37700									
15 Ton MS	8:1	75	5	21.9	890	1200	1780	2680	3570	5350	7140	10700	17850	26750						
			7.5	14.5	1310	1750	2620	3930	5240	7860	10480	15700	26200	39300						
			10	10.9	1725	2300	3450	5170	6900	10340	13800	20700	34500							
			15	7.3	2440	3250	4875	7310	9750	14600	19500	29250	46400							
			20	5.5	3160	4210	6320	9480	12640	18960	25300	37900								
			25	4.4	3880	5180	7760	11650	15500	23300	31000	46400								
			30	3.6	4050	5390	8100	12100	16200	24200	32300									
20 Ton MS	8:1	75	5	21.9	830	1100	1660	2490	3320	4980	6640	9960	16600	24900						
			7.5	14.5	1220	1620	2440	3650	4870	7300	9740	14600	24300	36500						
			10	10.9	1600	2140	3200	4800	6410	9600	12800	19200	32000	43200						
			15	7.3	2270	3020	4530	6800	9060	13600	18100	27200	45000							
			20	5.5	2930	3900	5850	8780	11700	17550	23400	35100								
			25	4.4	3600	4800	7200	10800	14400	21600	28800	43200								
			30	3.6	3780	5030	7550	11300	15100	22650	30200	43200								
		40	2.7	4950	6600	9900	14850	19800	29700	39600										

Using Reducer-Horsepower Tables

1. Listed actuator capacities consider reducer efficiencies and maximum power ratings.
2. Capacities are based on available reducer output torque and apply to both single actuator and shaft-connected, multiple actuator configurations. Capacity is the total load for all actuators driven by the reducer.
3. **Shaded capacities exceed the single actuator load rating or horsepower rating. In no case should any actuator be loaded beyond its nominal load rating, or at input powers greater than shown in the actuator specification chart on page 17.**
4. For multiple actuator configurations with total capacity greater than shown, contact Duff-Norton Application Engineering.

POWERED ACTUATORS

Machine Screw Actuators - Performance Specifications

Actuator Model	Actuator Ratio	Reducer Model	Reducer Ratio	Lifting Speed (in/min)	Lifting capacity (pounds)										
					Motor Horsepower(1725 rpm) / Frame Size										
					1 - 80L	1.5 - 90S	2 - 90L	3 - 100L	5 - 100L	7.5 - 132S	10 - 132M	15 - 160M	20 - 160L		
25 Ton MS	10.33:1	92672	4.85	22.2							24425				
			5.46	19.7							27540				
			5.92	18.2							20000	29830			
			6.78	15.9							22900	34260			
			7.73	13.9							26200	39160			
			8.71	12.4					12300	17900	29500	44090			
			9.78	11.0					13700	20200	33000	49500			
			11.02	9.8					15400	22600	37200	55720			
			12.64	8.5					17800	25800	42900	63920			
			14.08	7.7					19800	29000	47500	71100			
			16.08	6.7					22600	33000	54500				
			18.08	6.0					N.A.	37200	61400				
			20.37	5.3					N.A.	41600	68600				
			23.28	4.6					N.A.	48000	78800				
			26.55	4.1				27900	37000	54700					
			29.91	3.6				31800	42400	61400					
			34.17	3.2				35700	47600	70000					
			37.32	2.9			26500	39800	53000						
42.04	2.6			30000	44900	59800									
48.03	2.2			34400	50000	66700									
51.86	2.1			36500											
35 Ton MS	10.33:1	92772	4.81	22.4							22900				
			5.43	19.9							25860				
			6.11	17.6							29100				
			6.41	16.8							20300	30500			
			7.60	14.2							24100	36200			
			8.55	12.6							27160	40740			
			9.63	11.2							30600	45900			
			10.88	9.9					13800	20800	34700	52000			
			12.43	8.7					15800	23600	39400	59100			
			13.91	7.8					17600	26400	44000	66130			
			15.60	6.9					19800	29800	49600	74500			
			17.83	6.0					22750	34100	56900	85300			
			19.73	5.5					N.A.	37600	62700	94000			
			22.22	4.9					N.A.	42400	70700	106000			
			25.39	4.2					N.A.	48700	81000	121700			
			28.44	3.8					36180	54200	90400				
			32.04	3.4				30600	40800	61300	102200				
			36.61	2.9				35200	47000	70400	117400				
40.77	2.6			26900	40400	53900									
45.93	2.3			30650	46000	61300									
52.48	2.1			34450	51700	68900									
50 Ton MS	10.33:1	9042	8.83	12.2							42800	63400	84500		
			9.39	11.5							45400	67400	89900		
			10.21	10.6							49400	73300	97700		
			11.40	9.5							55300	82000	109000		
			13.40	8.0						48800	65100	96300	128000		
			15.66	6.9						56800	75800	112000	150000		
			18.20	5.9						66300	88500	130000	173000		
			20.32	5.3						74200	99000	145000	193000		
			23.89	4.5						86400	115000	170000	227000		
			27.91	3.9						101000	135000	200000			
			31.70	3.4						114000	153000				
			34.39	3.1						84000	126000	168000			
			40.54	2.7						97700	146000	195000			
			47.67	2.3						116000	175000				
55.69	1.9						81300	135000	203000						

Charts show available ratios and motors for close-coupled, IEC frame motors. Gear reducers with flange for NEMA C-face motor also available. Fitting of C-face motor will increase length of reducer-motor combination.

POWERED ACTUATORS

Ball Screw Actuators - Performance Specifications

Actuator Model	Actuator Ratio	Reducer Model	Reducer Ratio	Lifting Speed (in/min)	Lifting Capacity (pounds) - See Notes Below										
					Motor Horsepower(1725rpm) / Frame Size										
					1/4 - 56C	1/3 - 56C	1/2 - 56C	3/4 - 56C	1 - 56C	1.5 - 140TC	2 - 140TC	3 - 180TC	5 - 180TC	7.5 - 180TC	
2 Ton BS	6:1	31	5	14.4	3490	4650	6970	10460	13950					Note:180TC flange!	
			7.5	9.6	5000	6680	10000	15000							
			10	7.2	6400	8500	12750	19000							
			15	4.8	8650	11500	17300								
			20	3.6	10800	14400	21600								
			25	2.9	11400	17000									
			30	2.4	11800	17700									
2 Ton BS High Lead	6:1	31	5	57.5	980	1300	1960	2940	3900						
			7.5	38.3	1400	1880	2800	4200	5600						
			10	28.8	1800	2400	3600	5390							
			15	19.2	2400	3200	4800								
			20	14.4	3000	4000	6000								
3 Ton BS	6:1	31	5	23.7	2200	3100	4700	7000	9400						
			7.5	15.8	3380	4500	6750	10100	13500						
			10	11.9	4300	5700	8620	12900							
			15	7.9	5840	7700	11600								
			20	5.9	7300	9650	14600								
			25	4.7	8700	11500									
			30	4.0	9000	12000									
5 Ton BS	6:1	50	5	27.2	2280	3000	4550	6800	9100	13600	18200	27300*			
			7.5	18.2	3300	4400	6600	9900	13200	19800	26400				
			10	13.6	4300	5740	8600	12900	17200	25800	34500				
			15	9.1	5970	7950	11950	17900	23900	35800					
			20	6.8	7660	10200	15300	23000	30600						
			25	5.5	9250	12300	18500	27700	37000						
			30	4.5	9970	13300	19900	29900	39900						
5 Ton BS High Lead	6:1	50	5	57.4	1000	1330	2000	3000	4000	6000	8000	12000*			
			7.5	38.4	1450	1930	2900	4350	5800	8700	11600	17400*			
			10	28.7	1890	2520	3780	5670	7560	11300	15100				
			5	20.4	2750	3680	5500	8300	11000	16500	22100	33100	55200		
			7.5	13.6	4060	5400	8100	12200	16200	24300	32500	48700	81000		
			10	10.2	5300	7000	10570	15800	21100	31700	42300	63400			
			15	6.8	7450	9900	14900	22300	29800	44700	59500	89000			
10 Ton BS	8:1	63	5	5.1	9560	12750	19100	28700	38200	57400	76500				
			7.5	4.1	11600	15400	23100	34700	46300	69500					
			10	3.4	12700	16900	25400	38000	50750	76000					
			15	2.6	15700	20950	31400	47100	62800						
			5	43.0	1180	1575	2370	3550	4730	7100	9470	14200	23600		
			7.5	28.7	1740	2300	3480	5220	6960	10400	13900	20800	34800		
			10	21.5	2260	2990	4530	6800	9060	13600	18100	27200			
20 Ton BS	8:1	75	5	21.6	2500	3400	5150	7700	10300	15500	20600	30900	51500	77300	
			7.5	14.4	3780	5040	7570	11300	15100	22700	30300	45400	75700	113000	
			10	10.8	4980	6650	9970	14900	19900	29900	39900	59800	99700		
			15	7.2	7050	9400	14100	21100	28200	42300	56400	84500	140900		
			20	5.4	9140	12100	18200	27400	36500	54800	73100	109600			
			25	4.3	11400	15100	22750	34100	45500	68200	91000				
			30	3.6	11700	15600	23400	35000	46700	70000	93400				
20 Ton BS High Lead	8:1	75	5	43.1			2575	3850	5150	7750	10300	15450	25750	38650	
			7.5	28.7			2575	3850	5150	7750	10300	15450	25750	38650	

Ball Screw Actuators - Performance Specifications

Actuator Model	Actuator Ratio	Reducer Model	Reducer Ratio	Lifting Speed (in/min)	Lifting capacity (pounds)									
					Motor Horsepower(1725 rpm) / Frame Size									
					.50 - 71L	.75 - 80S	1 - 80L	1.5 - 90S	2 - 90L	3 - 100L	5 - 100L	7.5 - 132S		
25 Ton BS	10.33:1	92372	5.30	20.1					24600	35400	59000			
			5.97	17.9					27300	40200	66000			
			6.49	16.4						30000	43400	71800		
			7.32	14.6						33800	49300	81000		
			8.29	12.9						38000	55700	91700		
			9.47	11.3					32700	43400	63800	105000		
			10.84	9.8					37500	49900	72900	120000		
			11.39	9.4					39100	52500	76100	126000		
			13.01	8.2					44500	59500	87400			
			14.65	7.3					33800	50900	67500	114800		
			17.06	6.3					N.A.	59000	79400	128000		
			19.21	5.6					N.A.	66500	89000			
			21.95	4.9					N.A.	75600	100000			
			24.33	4.4			40800		56300	84100	112000			
			27.41	3.9			46100		63800	93800	125000			
			31.32	3.4			52000		71800	108000				
			33.80	3.2		37500	56300		77700					
			38.62	2.8		42300	64900		89000					
43.52	2.5		47700	73400										
49.73	2.1		54700	84000										
55.00	1.9		61700											
50 Ton BS	10.33:1	92672	4.85	33.4								60000		
			5.46	29.6									67600	
			5.92	27.3									49000	73200
			6.78	23.9									56300	84000
			7.73	20.9									64300	96000
			8.71	18.6							30200	43800	72400	108000
			9.78	16.5							33800	49500	81300	121500
			11.02	14.7							37800	55500	91300	136700
			12.64	12.8							43800	63500	105400	156900
			14.08	11.5							48700	71200	116700	175000
			16.08	10.1							55500	81300	134000	
			18.08	9.0							N.A.	91300	150000	
			20.37	7.9							N.A.	102000	168500	
			23.28	7.0							N.A.	118000	193500	
			26.55	6.1						68400	90900	134000		
			29.91	5.4						78000	104000	151000		
			34.17	4.7						87700	117000	172000		
			37.32	4.3					65200	97700	130000			
42.04	3.8					73600	110000	147000						
48.03	3.4					84500	122700	163700						
51.86	3.1					89700								

Using Reducer-Horsepower Tables

- Listed actuator capacities consider reducer efficiencies and maximum power ratings.
- Capacities are based on available reducer output torque and apply to both single actuator and shaft-connected, multiple actuator configurations. Capacity is the total load for all actuators driven by the reducer.
- Shaded capacities exceed the single actuator load rating or horsepower rating. In no case should any actuator be loaded beyond its nominal load rating, or at input powers greater than shown in the actuator specification chart on page 53.**
- For multiple actuator configurations with total capacity greater than shown, contact Duff-Norton Application Engineering.

POWERED ACTUATORS

Continuous Duty Actuators - Performance Specifications

Actuator Model	Actuator Ratio	Reducer Model	Reducer Ratio	Lifting Speed (in/min)	Lifting Capacity (pounds) - See Notes Previous Page								
					Motor Horsepower(1725rpm) / Frame Size								
					1/4 - 56C	1/3 - 56C	1/2 - 56C	3/4 - 56C	1 - 56C	1.5 - 140TC	2 - 140TC	3 - 180TC	5 - 180TC
7511 (3500lbs Max)	6:1	31	5	14.4	2200	3100	4700	7000	9400				
			7.5	9.6	3380	4500	6750	10100					
			10	7.2	4300	5700	8620						
			15	4.8	5840	7700							
			20	3.6	7300	9650							
7515 (12000 lbs max)	8:1	63	5	20.4	2880	3860	5770	8700	11500	17300	23200	34750	
			7.5	13.6	4260	5670	8500	12800	17000	25500	34125		
			10	10.2	5560	7350	11100	16590	22100	33280			
			15	6.8	7820	10400	15640	23400	31300				
			20	5.1	10000	13350	20000	30000					
75151 High Lead (5500lb)	8:1	63	5	43.0	1240	1650	2480	3720	4960	7450	9940	14900	
			7.5	28.7	1820	2400	3650	5480	7300	10900	14600		
			10	21.5	2370	3140	4750	7140	9500	14250			
7522 (27000 lbs Max)	10.67:1	75	5	27.2	3200	4300	6460	9700	12930	19400	25860	38800	64650
			7.5	18.2	4750	6320	9500	14250	19000	28500	38000	57000	
			10	13.6	6250	8320	12500	18750	25000	37500	50000	75000	
			15	9.1	8800	11700	17590	26380	35180	52750	70360		
			20	6.8	11450	15250	22900	34360	45800	68700			
75221 High Lead (13500lb)	10.67:1	75	5	57.4	1600	2150	3230	4850	6460	9700	12900	19400	32300
			7.5	38.4	2375	3160	4750	7120	9500	14250	19000	28500	
			10	28.7	3125	4160	6250	9370	12500	18750	25000	37500	

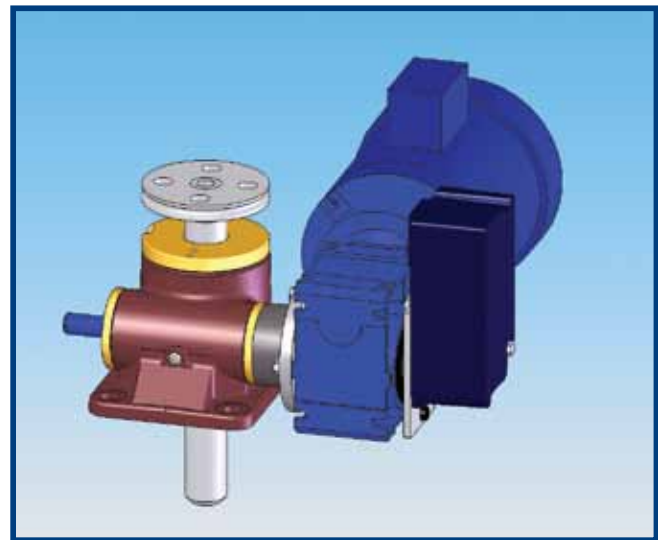
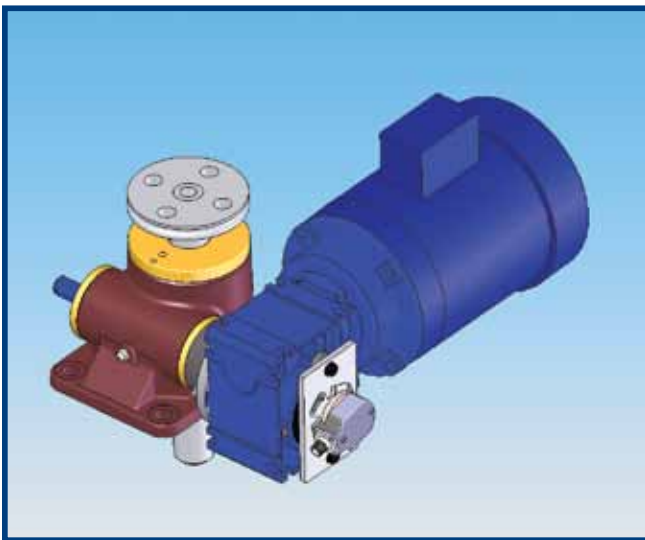

Does your application require mounting the limit switch or encoder on the reducer to allow another component to be mounted to the actuator's other side? No problem! Call our Customer Service team for assistance.

POWERED ACTUATORS

Motorized Actuator - Dimensions

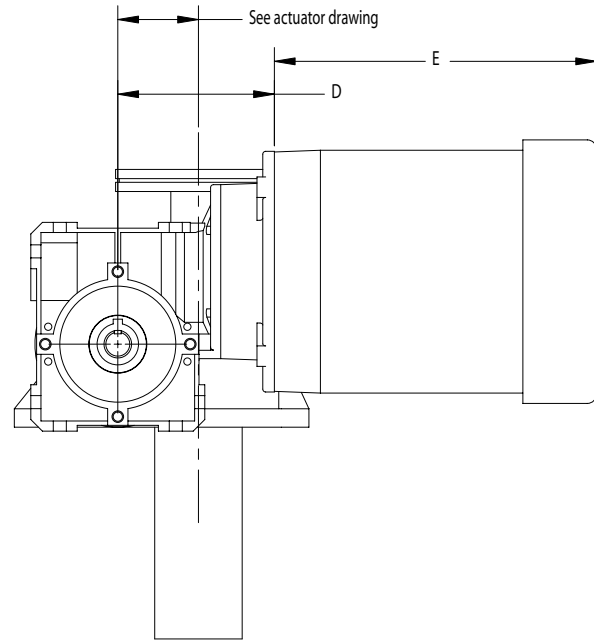
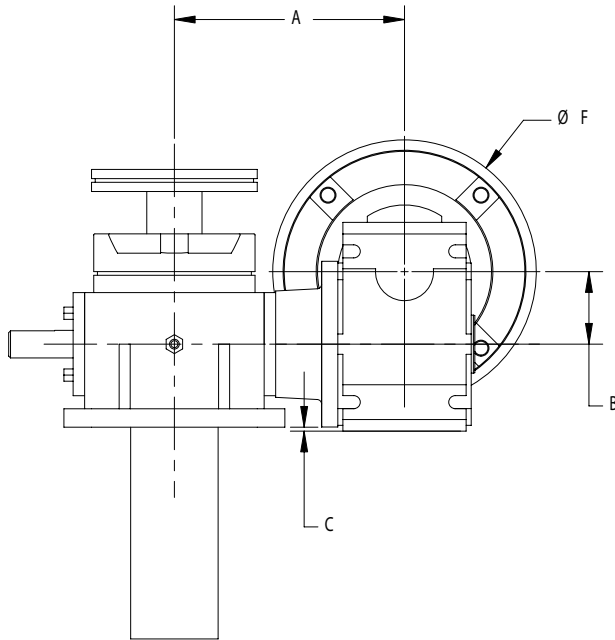

Actuator Capacity (tons)	Reducer Model	Motor Frame	A (in)	B (in)	C (in)	D (in)
2	31	56C	6.75	1.22	.17 Above	4.14
3	40	56C	6.75	1.57	.22 Below	4.17
		140TC	6.75	1.57	.22 Below	4.64
5	50	56C	6.25	1.97	.11 Below	4.26
		140TC	6.25	1.97	.11 Below	4.73
10	63	56C	7.59	2.48	.59 Below	4.85
		140TC	7.59	2.48	.59 Below	5.32
		180TC	7.59	2.48	.59 Below	6.45
15	75	56-140TC	7.40	2.95	.40 Below	6.09
		180TC	7.40	2.95	.40 Below	6.96
20	75	56-140TC	7.68	2.95	.14 Below	6.09
		180TC	7.68	2.95	.14 Below	6.96
25	92672	80	7.40	2.68	.40 Above	7.08
		90-100	7.40	2.68	.40 Above	7.63
		132	7.40	2.68	.40 Above	7.95
35	92772	80	11.49	2.87	.92 Below	7.95
		90-100	11.49	2.87	.92 Below	8.50
		132	11.49	2.87	.92 Below	9.09
50	9042	100-160	11.64	1.42 Below	3.80 Below	9.72

Motor HP	Frame	Motor without Brake		Motor with Brake	
		E (in)	F (in)	E (in)	F (in)
0.25	56C	7.50	7.16	11.50	7.16
0.33	56C	7.50	7.16	11.50	7.16
0.50	56C	8.00	7.16	13.00	7.16
0.75	56C	8.75	7.16	13.00	7.16
1	56C	9.25	7.16	13.50	7.16
1.5	140TC	9.75	7.16	15.00	7.16
2	140TC	10.75	7.16	16.00	7.16
3	180TC	11.37	9.22	16.12	9.22
5	180TC	11.87	9.22	16.62	9.22
7.5	210TC	16.50	10.81	22.25	10.81
10	210TC	22.87	10.81	25.00	10.81
0.25	63L	7.56	5.12	9.76	5.12
0.33	71S	8.43	5.71	10.71	5.71
0.50	71L	8.43	5.71	10.71	5.71
0.75	80S	9.29	6.50	11.81	6.50
1	80L	9.29	6.50	11.81	6.50
1.5	90S	10.87	7.20	13.82	7.20
2	90L	10.87	7.20	13.82	7.20
3	100L	12.05	7.91	15.63	7.91
5	100L	12.05	7.91	15.63	7.91
7.5	132S	12.83	8.98	16.49	8.98
10	132M	16.41	10.47	20.59	10.47
15	160M	18.83	12.60	25.40	12.60
20	160L	18.83	12.60	25.40	12.60

NOTES:

- Motors in shaded portion of table are close-coupled, IEC frame, standard on 25 to 50 ton actuators with reducers. NEMA C-face motors can be fitted to 25-50 ton units, with some increase in length. IEC frame motors can also be fitted to all other reducers, to reduce motor envelope size.
- Dimensions for NEMA C-face motors are typical for 1725 rpm, 3-phase, TEFC motors. Dimensions may vary somewhat depending on manufacturer.

POWERED ACTUATORS

Reducer Positions 2-20 Tons

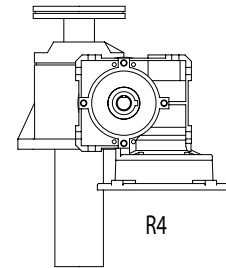
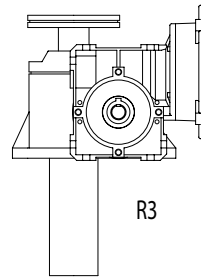
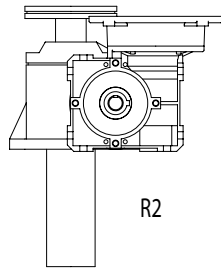
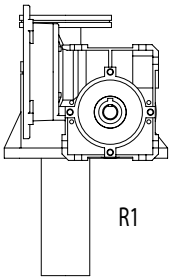
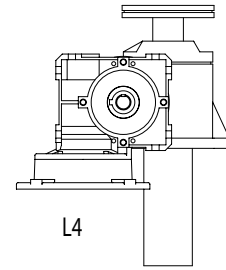
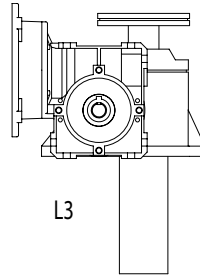
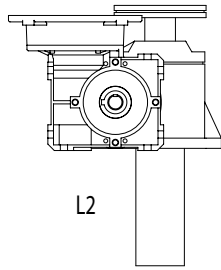
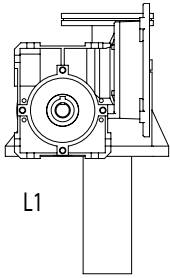

Reducer Positions 25-50 Tons

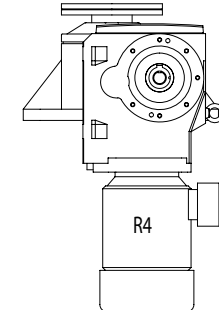
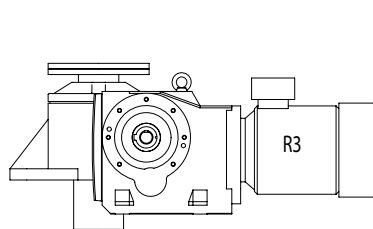
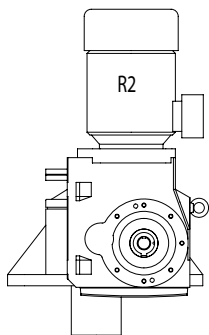
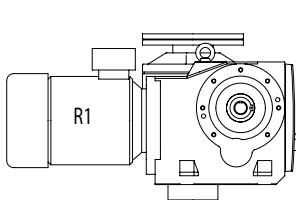
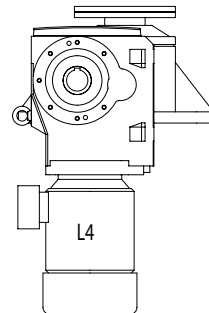
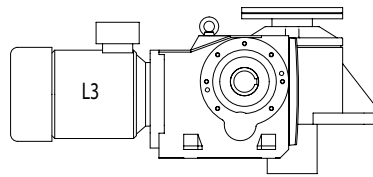
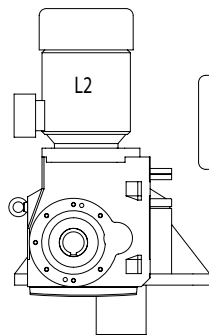
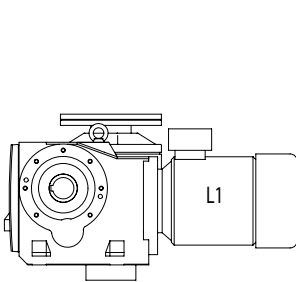

Actuator Motors

Duff-Norton can competitively supply motors for any application from suppliers such as Baldor, Nord, US Electric, Leeson, and more.

Features

Standard Motors Include:

- Brake and non-brake models
- Single and three phase models
- Explosion proof, washdown duty
- Wide variety of voltages and RPM's
- 50/60Hz models
- 1/4 to 10 Horsepower ratings
- Common NEMA frame size

Motors can be directly mounted to most Duff-Norton actuators using C-face adapters, directly mounted via speed reducers, or remotely mounted with shafting and couplings. IEC, servo, hydraulic, and air motors can also be supplied upon request.



C-Face Motor Driven

Please provide the following information when ordering:

- Actuator model
- Translating or rotating screw
- Upright or inverted configuration
- Type of screw end (translating screw actuators)
- Worm gear ratio
- Travel
- With or without boot
- With or without anti-backlash feature (machine screw actuators)
- Motor horsepower
- Motor frame size
- Left or right motor adaptor position
- Other special requirements

CAUTION: When direct coupling a motor to an actuator, it is necessary to match motor horsepower to actuator load. Lifting speeds and maximum actuator load capacities for actuators with various motor horsepower are shown in the table on the previous page. It is important that motors do not exceed the maximum horsepower shown.

CAUTION: All ball screw and high duty cycle actuators are self lowering and require motors with brakes. Standard ratio machine screw actuators are not always self locking and require motors with brakes. Optional ratio machine screw actuators are usually self-locking and do not require brakes. However, if self-locking is absolutely necessary, a motor brake or other restraining device should be considered.

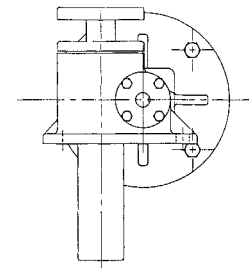
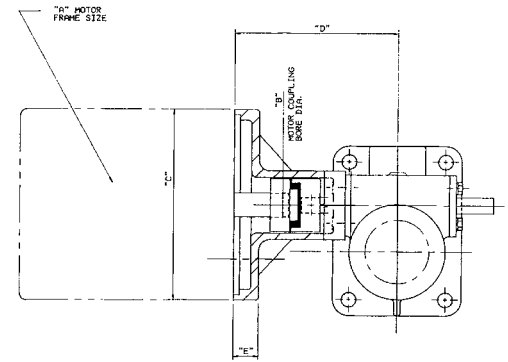

Dimensions

Capacity	A	B (+.001/-0.000)	C	D	E
2 Ton MS & BS, 3 Ton BS	56C	.625	6.75	6.16	.50
	143TC,145TC	.875	6.75	6.16	.50
3 Ton MS	56C	.625	6.75	6.17	.50
	143TC,145TC	.875	6.75	6.17	.50
5 Ton MS & BS	56C	.625	6.75	7.12	.62
	143TC,145TC	.875	6.75	7.12	.62
	182TC, 184TC	1.125	9.00	7.95	1.45
10 Ton MS & BS	56C	.625	6.75	8.13	.65
	143TC,145TC	.875	6.75	8.13	.65
	182TC, 184TC	1.125	9.00	8.97	1.47
15 Ton MS	56C	.625	6.75	8.13	.70
	143TC,145TC	.875	6.75	8.13	.70
	182TC, 184TC	1.125	9.00	8.97	1.54
20 Ton MS & BS	56C	.625	6.75	8.13	.65
	143TC,145TC	.875	6.75	8.13	.65
	182TC, 184TC	1.125	9.00	8.97	1.49
25 Ton MS & BS	56C	.625	6.75	8.88	.74
	143TC,145TC	.625	6.75	8.88	.74
	182TC, 184TC	1.125	9.00	9.63	1.49
35 Ton MS	56C	.625	6.75	8.78	.65
	143TC,145TC	.875	6.75	8.78	.65
	182TC, 184TC	1.125	9.00	9.63	1.49
7511	56C	.625	6.75	6.98	.50
	143TC,145TC	.875	6.75	6.98	.50
7515	56C	.625	6.75	8.06	.65
	143TC,145TC	.875	6.75	8.06	.65
	182TC, 184TC	1.125	9.00	8.90	1.47
7522	56C	.625	6.75	9.62	.65
	143TC,145TC	.875	6.75	9.62	.65
	182TC, 184TC	1.125	9.00	10.46	1.49

POWERED ACTUATORS

IEC Motor Driven - B-Face Motor Adaptor

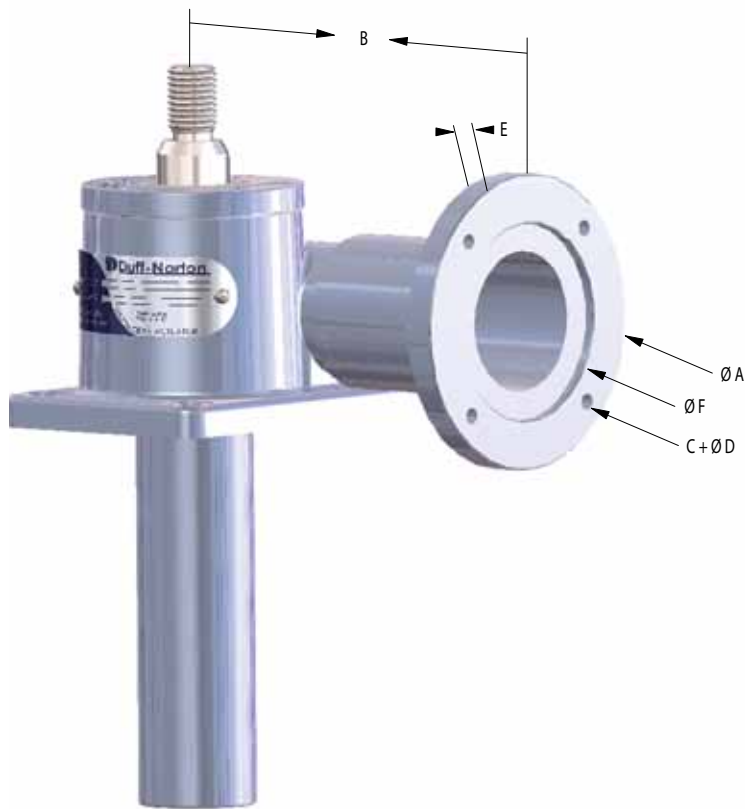

Features

- Available for 25-200kN G series screw jacks.
- Designed with Standard IEC B-face dimensions.
- Allows direct coupling of motor shaft with either the left or right side actuator input shaft.
- Comes with coupling, keys, and mounting hardware.
- NEMA motor adapters for our G series actuators are also available.

Dimensions

Capacity	IEC / Servo Flanges	A Flange O.D.	B Flange Length**	C Mounting Holes B.C.	D Mounting Holes Dia.	E Mounting Hole Depth	F Counter Bore Dia.
25kN - G9002	G9002 - 63B14	90	126	75	6	12.7	60
	G9002 - 71B14	105	133	85	7	12.7	70
	G9002 - 80B14	120	143	100	7	12.7	80
	G9002 - 90B14	140	153	115	9	12.7	95
50kN - G9005	G9005 - 71B5	160	178	130	M8 Tap	12.4	110
	G9005 - 80B5	200	178	165	M10 Tap	12.4	130
	G9005 - 90B5	200	178	165	M10 Tap	12.4	130
	G9005 - 100B14	160	181	130	9	15.7	110
	G9005 - 112B14	160	181	130	9	15.7	110
100kN - G9010	G9010 - 80B5	200	203	165	M10 Tap	12.2	130
	G9010 - 90B5	200	203	165	M10 Tap	12.2	130
	G9010 - 100B14*	190	213	130	9	10.0	110
	G9010 - 112B14*	190	213	130	9	10.0	110
150kN - G9015	G9015 - 80B5	200	203	165	M10 Tap	12.2	130
	G9015 - 90B5	200	203	165	M10 Tap	12.2	130
	G9015 - 100B14*	190	213	130	9	10.0	110
	G9015 - 112B14*	190	213	130	9	10.0	110
200kN - G9020	G9020 - 80B5	200	213	165	M10 Tap	20.1	130
	G9020 - 90B5	200	213	165	M10 Tap	20.1	130
	G9020 - 100B14*	190	223	130	9	10.0	110
	G9020 - 112B14*	190	223	130	9	10.0	110
300kN - G9030	G9030 - 80B5	200	257	165	M10 Tap	20.1	130
	G9030 - 90B5	200	257	165	M10 Tap	20.1	130
	G9030 - 100B14*	190	267	130	9	10.0	110
	G9030 - 112B14*	190	267	130	9	10.0	110

Note: All dimensions are shown in millimeters. All couplings are purchased separately from the motor flange kit.

Use an adapter plate mounted to the G9010-80B5, G9015-80B5, G9020-80B5 and G9030-80B5 Flanges respectively.

Adapter plates should be mounted to the motor, and then to the motor flange

Mounts to the jacks' casting, and replaces the worm cover

IEC Motor Driven - B-Face Motor Adaptor

Please provide the following information when ordering:

- Actuator model
- Worm gear ratio
- With or without anti-backlash feature (machine screw actuators)
- Motor horsepower
- Motor frame size
- Left or right motor adaptor position
- Other special requirements

Performance Specifications for 50 Hz Motor

		LIFTING CAPACITY (Newtons)										
Actuator Capacity	Worm Gear Ratio	Speed	MOTOR kW									
		(mm/min)	0.12	0.18	0.25	0.37	0.55	0.75	1.10	1.50	2.20	3.70
		RPM	MOTOR RPM @ 50 Hz									
		1450	1450	1450	1450	1450	1450	1450	1450	1450	1450	1450
25 kN	6:1	1450	290	800	1380	2400	3910	5600	8550	11920	—	—
	12:1	725	650	1780	3090	5340	8710	—	—	—	—	—
	24:1	362.5	470	1270	2210	3830	—	—	—	—	—	—
50 kN	6:1	2175	—	—	460	1170	2230	3420	5490	7860	12000	—
	12:1	1087.5	—	—	990	2510	4800	7340	11780	16860	—	—
	24:1	543.75	—	—	720	1830	3500	—	—	—	—	—
100 kN	8:1	2175	—	—	—	—	1180	2330	4340	6630	10640	19240
	24:1	725	—	—	—	—	2230	4390	8170	—	—	—
150 kN	8:1	2175	—	—	—	—	1090	2140	3990	6110	9810	17730
	24:1	725	—	—	—	—	2060	4050	7540	—	—	—
200 kN	8:1	2175	—	—	—	—	170	1130	2830	4770	8160	15420
	24:1	725	—	—	—	—	320	2140	5340	—	—	—
300 kN	10 2/3:1	2175	—	—	—	—	—	—	950	2530	5300	11220
	32:1	725	—	—	—	—	—	—	1590	4230	—	—

Ratings with N.A. in their cells have either exceeded the B-face flange frame size, or the single screw jack kilo-watt rating. In no case should any screw jack be loaded or have a power supply beyond its' rating or damage will likely result.

Performance Specifications for 60 Hz Motor

		LIFTING CAPACITY (Newtons)										
Actuator Capacity	Worm Gear Ratio	Speed	MOTOR kW									
		(mm/min)	0.12	0.18	0.25	0.37	0.55	0.75	1.10	1.50	2.20	3.70
		RPM	MOTOR RPM @ 60 Hz									
		1700	1700	1700	1700	1700	1700	1700	1700	1700	1700	1700
25 kN	6:1	1700	140	570	1080	1940	3230	4670	7180	10060	—	—
	12:1	850	320	1280	2400	4320	7200	—	—	—	—	—
	24:1	425	230	920	1720	3100	—	—	—	—	—	—
50 kN	6:1	2550	—	—	240	850	1760	2760	4530	6550	10080	17650
	12:1	1275	—	—	520	1820	3770	5940	9730	14060	—	—
	24:1	637.5	—	—	380	1330	2750	—	—	—	—	—
100 kN	8:1	2550	—	—	—	—	720	1700	3410	5360	8790	16120
	24:1	850	—	—	—	—	1360	3200	6430	—	—	—
150 kN	8:1	2550	—	—	—	—	660	1560	3140	4940	8100	14860
	24:1	850	—	—	—	—	1250	2950	5920	—	—	—
200 kN	8:1	2550	—	—	—	—	—	600	2050	3700	6590	12780
	24:1	850	—	—	—	—	—	1140	3860	—	—	—
300 kN	10 2/3:1	2550	—	—	—	—	—	—	310	1660	4020	9070
	32:1	850	—	—	—	—	—	—	520	2770	—	—

Ratings with N.A. in their cells have either exceeded the B-face flange frame size, or the single screw jack kilo-watt rating. In no case should any screw jack be loaded or have a power supply beyond its' rating or damage will likely result.

▲ **CAUTION:** When direct coupling a motor to an actuator, it is necessary to match motor horsepower to actuator load. Lifting speeds and maximum actuator load capacities for actuators with various motor horsepower are shown in the tables above. It is important that motors do not exceed the maximum horsepowers shown.

▲ **CAUTION:** Standard ratio machine screw actuators are not always self locking and require motors with brakes. Optional ratio machine screw actuators are usually self-locking and do not require brakes. However, if self-locking is absolutely necessary, a motor brake or other restraining device should be considered.

POWERED ACTUATORS

Actuator Hand Wheels

The Duff-Norton hand wheel is for actuator customers who may require precise positioning, or may have loads which do not require motorized power to adjust.

Features

- Easy installation to existing actuators. All hand wheels are bored, keyed, and set-screw drilled to the proper dimensions
- Revolving handle design for rotational ease
- Recessed hub and spoke design
- Cast iron material with chrome plating

Note: Hand wheels are not recommended for use with ball screw actuators as they contain no braking system. Also, for models with 12:1 ratio's and lower, an additional locking mechanism to prevent backdriving is recommended.



The table below presents dimensional information for all Duff-Norton Hand Wheels. To properly select the best hand wheel for your application, please review the provided information, or contact our customer service team.

Model #	Capacity	Dia.	Width*	Bore Size	Keyway Size
HW04-.375	1/4 & 1/2 Ton MS & BS	4"	3 3/8"	0.375	1/8 x 1/16 x 1
HW06-.375	1/4 & 1/2 Ton MS & BS	6"	4"	0.375	1/8 x 1/16 x 1
HW04-.500	1 & 2 Ton MS & BS	4"	3 3/8"	0.500	1/8 x 1/16 x 1
HW06-.500	1 & 2 Ton MS & BS	6"	4"	0.500	1/8 x 1/16 x 1
HW04-.625	3 Ton MS & BS	4"	3 3/8"	0.625	3/16 x 3/32 x 1
HW06-.625	3 Ton MS & BS	6"	4"	0.625	3/16 x 3/32 x 1
HW06-.750	5 Ton MS & BS	6"	4"	0.750	3/16 x 3/32 x 1 1/4
HW08-.750	5 Ton MS & BS	8"	6 3/16"	0.750	3/16 x 3/32 x 1 1/4
HW10-.750	5 Ton MS & BS	10"	5 3/4"	0.750	3/16 x 3/32 x 1 1/4
HW08-1.00	10-20 Ton MS & BS	8"	6 3/16"	1.000	1/4 x 1/8 x 1 1/2
HW10-1.00	10-20 Ton MS & BS	10"	5 3/4"	1.000	1/4 x 1/8 x 1 1/2
HW12-1.00	10-20 Ton MS & BS	12"	6 1/2"	1.000	1/4 x 1/8 x 1 1/2

From the end of the handle to the end of the hub

Duff-Norton, the market leader in Screw Jack technology has been supplying customers worldwide with lifting devices for over 125 years and with customized control systems to enable precision movement for over 17 years.



Features

Duff-Norton control systems provide

- Fewer interfaces
- Better Performance
- One integrated system
- Automated machine cycling
- Scalable hardware and software

Why buy from Duff-Norton?

- Duff-Norton electronic control systems are based on programmable microcontrollers set on either a board or in an enclosure.
- All design, manufacture and programming is carried out by Duff-Norton engineers and technical personnel.
- At Duff-Norton we work closely with our customers to gain an understanding for the associated applications in order to develop the optimum solution.
- One stop shopping for relatively simple configurations or for the development of complex solutions to suit your specific custom requirements.
- Duff-Norton controllers can be mounted within a shock proof enclosure or integrated within the customer's existing control panels.



ACTUATOR CONTROLS

Features & Benefits

Duff-Norton designs and manufactures a wide range of electronic logic control systems that are optimized for linear motion control and general automation applications. Duff-Norton can provide you with a complete turnkey solution to meet all your custom solution requirements. Our control panels are installed by our factory trained technical personnel therefore there is no need for customers to spend time fidgeting with wires or adding components.

Duff-Norton control panels can be designed around 3 hp to 200 hp systems with ratings from 200 V to 575 V

Features

Standard Feature

- UL approved, heavy-duty NEMA 12 enclosure
- Manual and touch screen interface
- UL approved control panels on request
- Spacious layout for simple installation

Benefits

Standard Benefits

- Improving speed and precision
- Simplifying operation and operator interface
- Automating repetitive tasks
- Complete turnkey solutions

Electric control systems support a wide range of applications:

Duff-Norton has designed and provided numerous control panels with simple operator controls, limit indicators, position potentiometer, position feedback, along with the required “in-sight” disconnect motor and motor circuit protection to make complying with safety regulations and electrical codes easy.

Industry specific expertise in the following areas:

- Extend, retract, lifting and lowering equipment
- Position synchronization
- Position control

Software:

- PLC Panels
(Siemens, Allen Bradley, Rockwell Automation)
- Operator Interface (Siemens)
- AC Inverters (Siemens, Allen-Bradley, Yaskawa)



Duff-Norton Offers Turnkey Solutions for Applications in the Following Markets



Rail Maintenance Equipment

Duff-Norton designs and manufactures a wide range of Rail Shop Equipment for performing maintenance and inspection work on locomotive and rail car transport vehicles. Duff-Norton Rail Shop Equipment products support a broad range of lifting heights, weights and vehicle dimensions. Our products consist of in-ground lifting systems, mobile and fixed lifting jacks, drop tables, car hoists, turntables and workshop equipment. Duff-Norton will design and install a custom system that's tailored to fit your lifting needs.



Stage & Theatre

Duff-Norton designs and manufactures a wide range of equipment for stages and theatre applications. We use acme screws, winches, and hoists in the design and install stage and theatre lifts in addition to products that move props, lower podiums or shift floors. Duff-Norton offers a total solution that conforms perfectly with your demands and requirements. Our actuators and lifting elements are fast, efficient, reliable and safe. These systems require only a minimal amount of routine maintenance each year, which can be scheduled for times when the facility is not normally in operation.



Motion Solutions

Duff-Norton is a designer and manufacturer of complete turnkey solutions for a variety of industries such as aluminum, steel, agriculture, construction, communications, energy, food & beverage and industrial machinery. If you want to tilt an object fixed at one end, lift, lower, roll, slide, open or close an object or if you have an application that requires periodic adjustment, Duff-Norton can use linear actuators and electrical cylinders to design a custom solution that's tailored to your specific needs.

ACTUATOR CONTROLS

Rotary Limit Switches

SKA Series Rotary Limit Switch

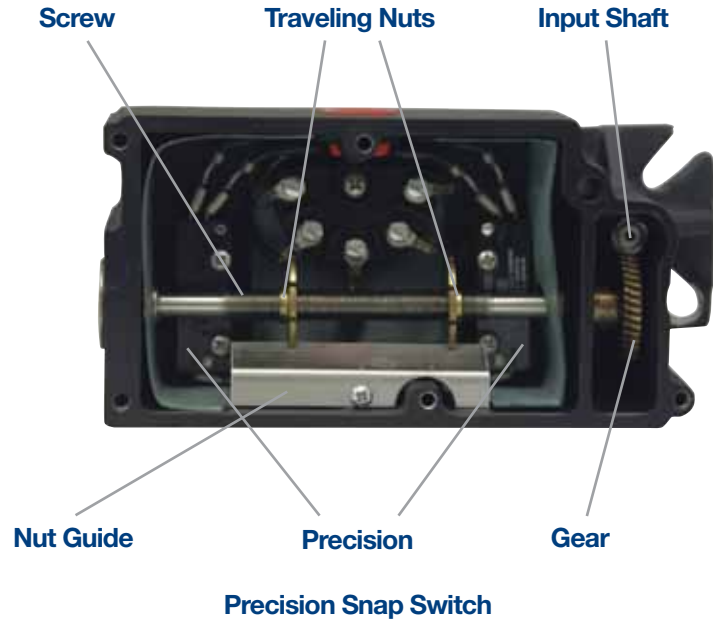

Features

- Available in two control voltage ratings: 250 or 480, and in three gear ratios.
- Can be used in applications where there is a need to control equipment that rotates and/or reverses.
- Sturdy and compact. Constructed of corrosion-resistant materials, with housing of black anodized aluminum. Meets NEMA-4 water tightness requirements.
- Simple to adjust. Two switches, one for up/stop and one for down/stop, are activated by the adjustable limit-switch nuts which travel laterally when the internal screw is rotated through gear reduction.
- Operating temperature range -20° to + 150°F.
- Lifetime lubricated.
- Can be mounted on right or left extension of actuator worm shaft in any of four quadrants.
- Optional 4-position limit switch available. Consult factory for dimensions.

To ensure that limit switch has sufficient travel capability for the actuator unit, use the following formula:

Maximum raise of actuator model in inches =

$$\frac{\text{Maximum Input Revolutions of Limit Switch}}{\text{Turns of Actuator Worm per Inch of Raise}}$$

Note: For water-tight connection, use a weather-tight connector and sealant around threads. Limit switches will be damaged if overtraveled. For shipping purposes, the 1/2" NPT hole is closed with a plastic plug which is not water tight.

Rotary Limit Switches



Rotary Limit Switch Performance Specifications

Model No.	Max. Voltage		Max. Amps		Max.	Max.	Max. Allow- able Drift	Notch Adjustment
	AC	DC	AC	DC	Worm Rev.	Rise		
SKA6000AT10	250		15		1095	1095/TPI	24/TPI	1/TPI
SKA6000AT20					2190	2190/TPI	48/TPI	2/TPI
SKA6000AT40					4380	4380/TPI	96/TPI	4/TPI
SKA6000BT10	480	125	15	.50	750	750/TPI	29/TPI	1/TPI
SKA6000BT20					1500	1500/TPI	57/TPI	2/TPI
SKA6000BT40		250				3000	3000/TPI	115/TPI

TPI = Turns per Inch of Raise of Actuator Unit

Rotary Limit Switch Mounting and Adjustment

All models except
75, 100, and 150 Ton

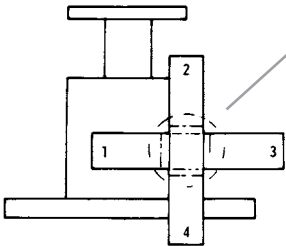

Switch Position

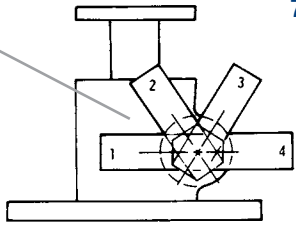

75, 100, and 150 Ton only

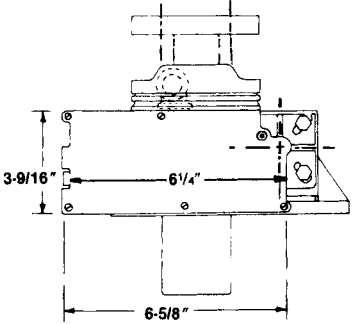
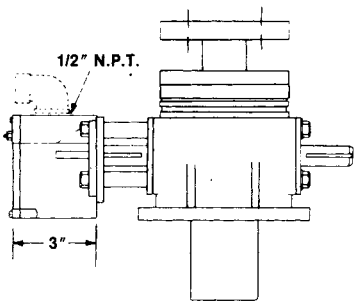

ACTUATOR CONTROLS

Rotary Limit Switches

Limit Switch Field Installation Dimensions

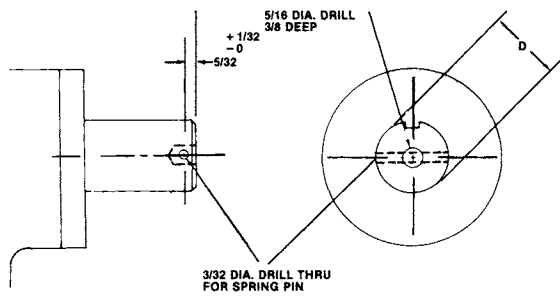

*NOTE: SHIM OUT ON LIMIT SWITCH IF NECESSARY.
WORM SHAFT END MUST NOT RUB SWITCH HOUSING.

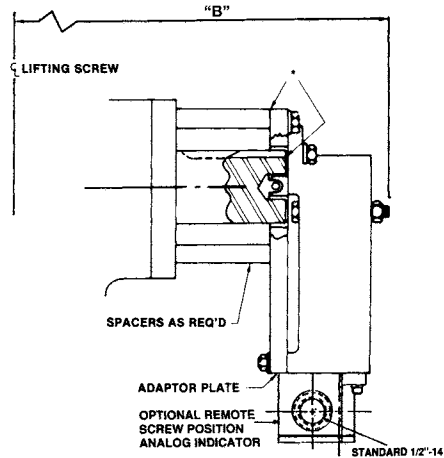
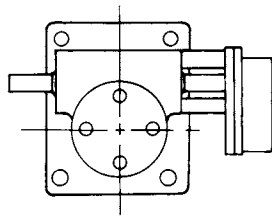

Worm Shaft Dimensions

Capacity	Mounting Dimensions	Worm Shaft Dia.
2 & 3 Ton MS	6 3/4	.500
3 Ton BS	6 3/4	.500
5 Ton MS & BS	7 3/4	.750
10-15 Ton MS & BS	8 3/4	1.000
20 Ton MS & BS	8 3/4	1.000
25 Ton MS & BS, 35 Ton MS	10 1/4	1.375
50 Ton MS & BS	14 1/4	1.500
75 Ton MS	15 1/4	1.750
100 Ton MS	14 3/4	1.750
150 Ton MS	14 3/4	1.875

Note: Limit switch cannot be fitted directly to 1/4, 1/2 and 1 Ton series. anti-backlash mounting is the same as machine screw actuators. Dimensions are subject to change without notice.

Rotary Limit Switch Electrical Wiring Diagram and Setting Instructions

- ▲ CAUTION: Disconnect power before making any adjustment.
- Check drift before adjusting limits.
- Remove screw "A" and nut guide keeper "B" to adjust limits.
- Run actuator unit to desired limit.
- Rotate appropriate nut until switch clicks, then turn 1/2 turn more.
- Replace "A" and "B."
- Run actuator unit to other limit.
- Repeat steps 2, 4 and 5 to adjust this nut.

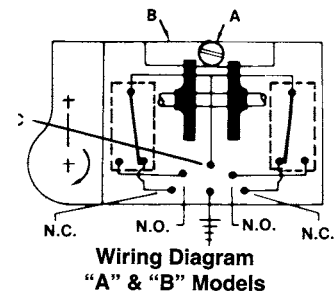

N.O. = Normally Open
N.C. = Normally Closed

Slight adjustments may be necessary. See Performance Specification Chart on the previous page for notch adjustment value.

Potentiometer / Transducer

The Duff-Norton SKA6205 Series Position Feedback Potentiometer/Transducer is designed to mount on the end of any SKA6000T limit switch. Its active component is a precision potentiometer which may be used as voltage divider to provide a feedback voltage that is proportional to actuator position.

Features

- Multiple gear ratios allow for a wide range of raises.
- Standard resistance is 5000 ohms. Other resistances are available on special order.
- Power rating: 2 watts at 40°C
- Max. service temp.: 85°C
- Interface directly with the Model SK6300-4K Digital Position Indicator to provide a scalable readout of position. The SKA6205 series models can also be used with most motor controls that have provision for potentiometer feedback signal.
- Transducer supplied with black anodized finish as standard.

Potentiometer Performance Specifications

Model	Max. Turns Potentiometer Worm Shaft
SKA6205-30	30
SKA6205-50	50
SKA6205-60	60
SKA6205-100	100
SKA6205-200	200
SKA6205-400	400

Note: When used with Duff-Norton actuators and limit switched the potentiometer selection should be:

Desired pot turns = total stroke x Worm turns per inch / L.S. gear ratio

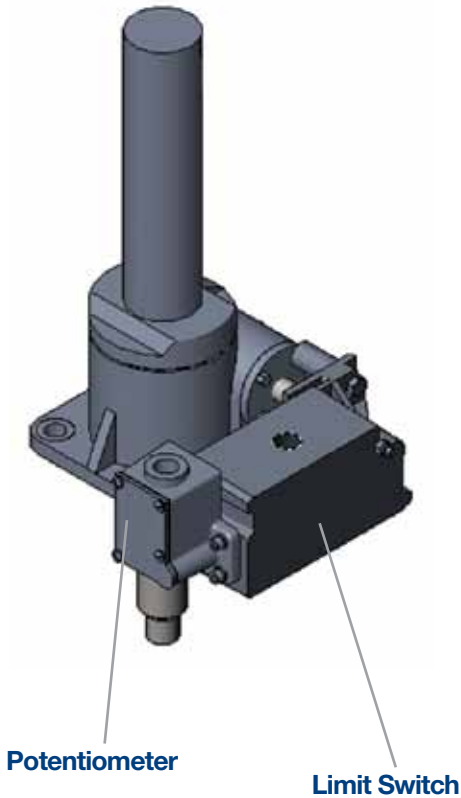
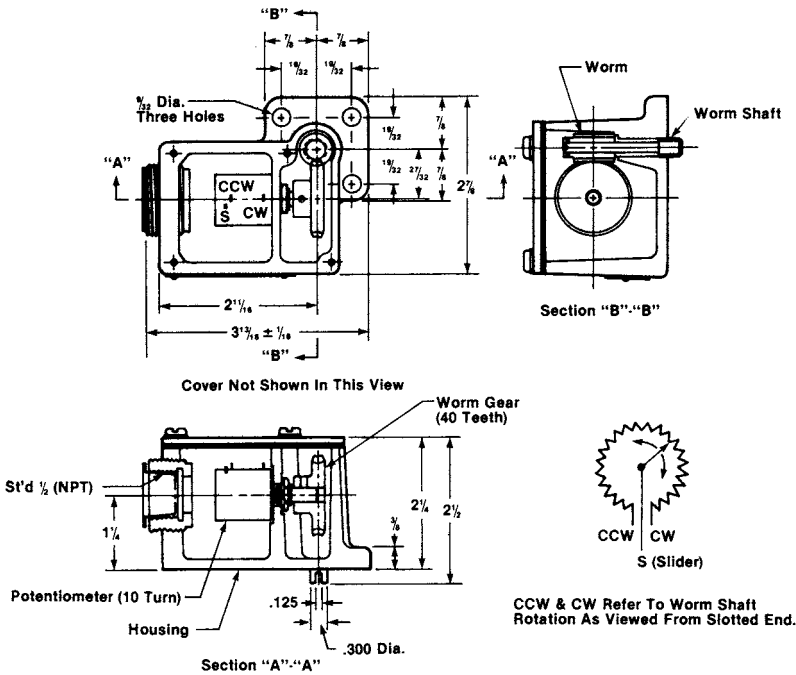

Note: Transducer shipped unattached, to be installed at site. Includes required mounting hardware; soldering to potentiometer required.

ACTUATOR CONTROLS

Digital Position Indicator for Duff-Norton Potentiometers

The Duff-Norton model SK6300-4K Digital Position Indicator processes a feedback signal from a the SKA6205 series potentiometers to provide position readout with user selectable scaling factor. By running the actuator to two positions in its stroke and keying in the desired readout at each point, the indicator automatically scales the input signal to provide linear readout over the full travel of the actuator.

The SK6300-4K has a universal, 85-250 VAC power input and generates a regulated 24 VDC excitation signal to the potentiometer. The SK6300-4K operates seamlessly with any potentiometer equipped Duff-Norton actuator.



Features

- Self scaling by inputting minimum and maximum readings – either by key stroke or input signal
- Two adjustable up / down limits with 0 to +/- 99999
- Accepts 1K to 10K potentiometer inputs
- Programmable decimal point location
- Input power requirement from 85 – 250 VAC
- Programmable front panel functions
- For use with Duff-Norton 2 through 150 ton machine or ball screw actuators

DIMENSIONS In inches (mm)

Note: Recommended minimum clearance (behind the panel) for mounting clip installation is 2.1" (53.4) H x 5.0" (127) W.

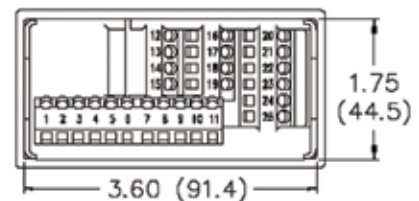
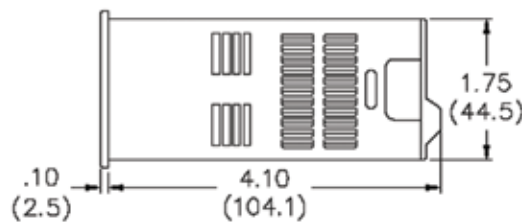
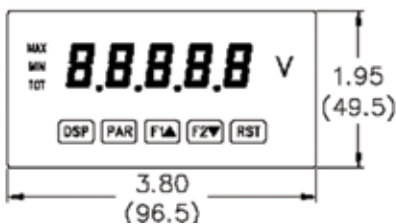

Worm Shaft Encoder

The Duff-Norton Digital Encoder and Digital Display is a more advanced way to determine an actuator's position.

A digital encoder can be used to provide an extremely precise position signal to devices such as the Duff-Norton SK10006-35 digital display or 3rd party PLC's.

Duff-Norton uses two styles of incremental encoders, with the type used depending on the layout of the actuator. When one end of the actuator worm shaft is accessible, a Hollow Bore style of encoder is used, mounted on the worm. When the worm is not accessible, and the actuator is using a flange-mounted motor, a Ring Kit style encoder can be fitted on the drive motor.



Digital Incremental Encoders

The EN260C60 is a compact yet rugged encoder designed for harsh factory environments and can easily accommodate clockwise or counter clockwise rotational requirements. Standard encoders are low-level, open collector output. Push-pull and line driven outputs are also available. Installation or removal is quick and simple. A M12, 5-pin body mount connector is provide as standard, and a shielded 4-meter cable with connector is available. Contact Duff-Norton Application Engineering for more specifics.

Features

- Up to 600 pulses per revolution (60 ppr standard)
- Pulse frequency - 200kHz, with a 90° phase shift
- Input voltage - +5 VDC to +28VDC
- Operating temperature (-0° to +70°C)
- Shock resistance to 200g, vibration resistance to 10g
- IP 64 rated seal
- Black non-corrosive housing

Function	Cable Wire Color
Com	Black
+VDC	White
A	Brown
B	Red

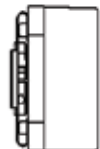
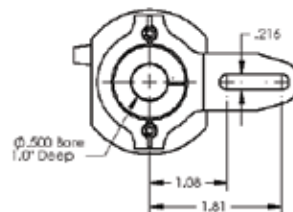
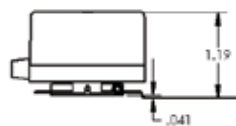
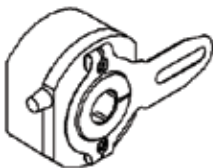

ACTUATOR CONTROLS

Ring Kit Encoder

The Ring Kit Encoder counts motor revolutions and is mounted between the C-face motor and motor mounting flange. This mounting allows the actuator worm opposite the motor to be available for mounting a limit switch or driving another actuator. With 60 pulses per motor revolution, the ring kit offers a high pulse count relative to actuator travel. A small junction box with NPT opening is attached to the ring, allowing easy, protected electrical connections. Available for all sizes of NEMA C flanges used on Duff-Norton actuators. Additional output types available. Contact Duff-Norton Application Engineering for specifics.



Specifications

Sensor Type.....	Bidirectional shaft speed sensor
Pulse Per Revolution	60 cycles each channel
Supply Voltage	+12 Volts DC +/-5%
Supply Current	60 mA typical (115 mA maximum)
Output Drive Capability	250 mA per channel continuous
Maximum Load.....	50 ohms per channel

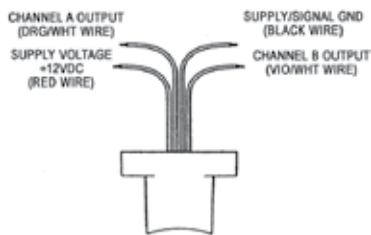

Electrical Connections

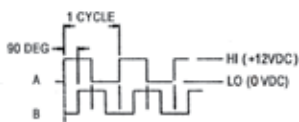

Output Channel Waveforms

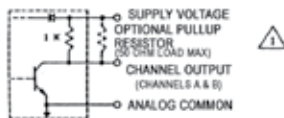

Output Channel Schematic (Channels A & B)

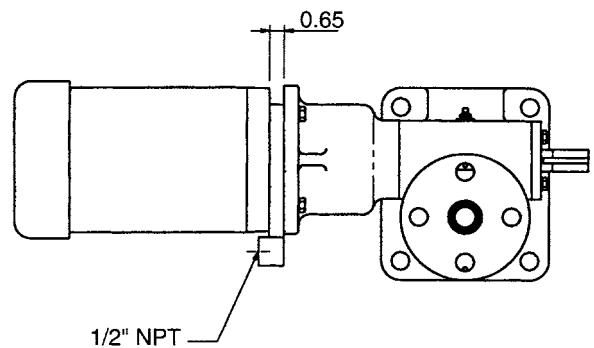

Electrical Connections

Programmable Digital Position Indicator for Duff-Norton Encoders

Displays position of actuator lifting screws in increments of up to .001", depending on PPR (Accuracy is relative to ratio and backlash. Please consult factory for details).



The Duff-Norton SK10006-35 Digital Position Indicator provides a high degree of accuracy and versatility when incorporated in machine or ball screw actuator systems. Operating as a revolution counter, it is ideal for use in a wide range of precision positioning applications to indicate inches or millimeters of lifting screw travel. Two built-in relays act as limit switches for travel limit control. Start-up/shut-off, audio/visual warning, multiple actuator system sequencing or the initiation of subsequent operations may also be controlled.

Electrical connections are made at the rear of the unit to UL recognized terminal strips. Clamp-type pressure plate terminals accept AWG-14 wire without lugs.

Features

- Five digit input scaling with 0.0000 to +/- 5.0000, programmable decimal point location and lead zero blanking.
- Two adjustable up/down output limits with 0 to +/- 999999.
- Non-volatile E2-PROM Memory retains all programmed information and count value in event of power interruption.
- Input power requirement is 115/230 VAC, 50/60 Hz.
- Can be provided with optional 4 - 20 mA current loop to provide capability of 2-way digital communication.
- On-line self-test permits complete check of all functions and reset capability allows reset to zero from front panel.
- Compact, die cast NEMA 4 rated front panel has six digit LED display with 0.56" high characters and negative sign (-). Display convertible to English, metric or other units of measurement.
- Field Programmable front panel functions may be locked out to prevent unauthorized adjustment.
- For use in precision positioning applications with Duff-Norton 2 ton and larger machine or ball screw actuators.

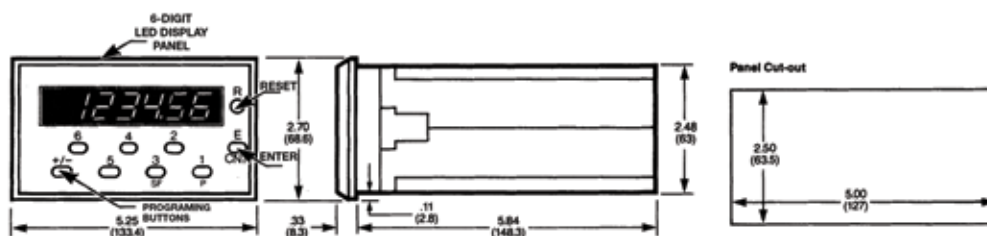

ACTUATOR CONTROLS

Magnetostrictive Position Sensor

Duff-Norton offers Magnetostrictive Position Sensors for machine and ball screw actuators. These sensors offer analog or digital outputs, and can be used for accurate position indication or with a PLC in a closed loop control system. Magnetostrictive position sensors are non-contacting, resulting in longer life than other linear transducers or potentiometers.

Due to the fact that the magnet senses actual screw displacement, position indication is absolute and unaffected by gearset backlash.

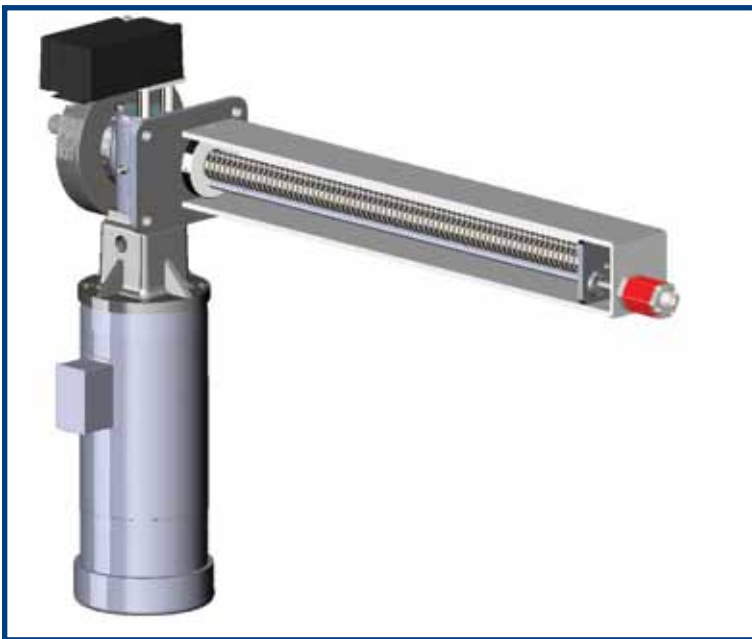

Typical installation on lower capacity models where the sensor is mounted parallel to the screw.

Features

- Absolute Position Indication
- Non-Contacting, Magnetostrictive Technology
- Replaceable Sensing Element
- Fully Enclosed in Actuator Coverpipe
- Lengths up to 60 inches (0525mm)
- Shock and Vibration Resistant
 - Analog or Digital Outputs:
 - Voltage 0 to +10 VDC or +10 to 0 VDC
 - Current (4-20 MA or 0-20 MA Grounded)
 - Start/Stop
 - Pulse Width Modulated
- Open or Closed Loop Control
- Available for a wide range of Duff-Norton Machine and Ball Screw Actuators

Specifications

Supply Voltage	+15 to 26 VDC
Non-Linearity	$\pm 05\%$ of Full Scale or to .002 in. (± 0.05 mm) whichever is greater
Repeatability	$\pm 0.001\%$ of Full Scale. or \pm 0.0001 in. (± 0.002 mm) whichever is greater
Hysteresis	0.0008 in. (0.076 mm) max.
Measuring Range	U.S. Customary: 1 to 60 in. (0.1 in. increments) Metric: 50 to 1500 mm (5 mm increments)



Typical installation on higher capacity models where the screw is "gun drilled" with the sensor mounted inside the screw.

Rotary Counters

The Duff-Norton Rotary Counter is for actuator customers who are looking for a more economical and easy way to determine an actuator's position. Our counters have been designed to match our most common actuator ratios. An operator viewing the reading in the display window will know his actuator's exact position because the counter's display shows stroke to the nearest 1000ths of an inch up to 99 inches of travel. Custom numeric displays are also available.



Features

Some of the more important features are:

- Display readings have been pre-matched to the actuator's ratios.
- Display reading has been extended to the nearest 1000ths of an inch.
- Clockwise and counter clockwise models available.
- Easy mounting kits available for installation to existing field actuators.

Model#	Turns of Worm For 1" Raise	MS Actuator Capacity and Ratio			Approx. Width
		Standard	Optional 1	Optional 2	
Clockwise rotation					
RC16R	16	5-100 Tons			2"
RC24R	24	2-3 Ton			2"
RC32R	32			5 Ton	2"
RC48R	48		10-100 Ton	2-3 Ton	2"
RC64R	64		5 Ton		2"
RC96R	96		2-3 Ton		2"
RC100R	100				2-25 Ton
Counter clockwise rotation					
RC16L	16	5-100 Tons			2"
RC24L	24	2-3 Ton			2"
RC32L	32			5 Ton	2"
RC48L	48		10-100 Ton	2-3 Ton	2"
RC64L	64		5 Ton		2"
RC96L	96		2-3 Ton		2"
RC100L	100				2-25 Ton

Note: counter models with either 24 or 96 turns will be short .002" per inch. For those models, instead of a 1.000" reading, one would have a .998" reading.

Rotary Counter Installation

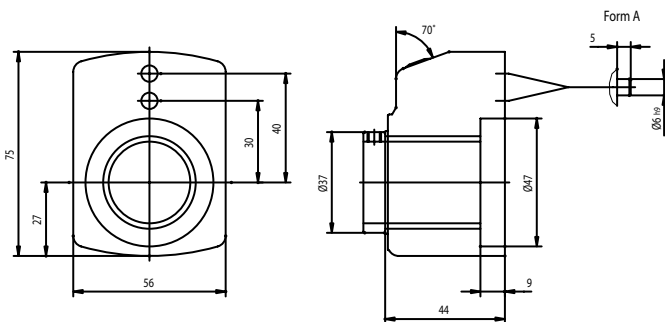

Note: All dimensions in millimeters.

Rotary Counters - Mounting Information

The Duff-Norton Rotary Counter fits over the actuator's worm shaft. A special worm bushing fills dimensional difference between the counter's bore and the worms' diameter (see table). An anti-rotation pin from the counter's rear into the actuators' worm flange holds the counter steady.

Model #	Bore Size	Capacity
SK8001-6	.500"	2 Ton MS
BU10-.625	.625"	3 Ton MS
BU10-.750	.750"	5 Ton MS
BU10-1.00	1.00"	10 - 20 Ton MS

Note: Capacities greater than 20 Tons have their worm diameters turned down to size.

POWER TRANSMISSION COMPONENTS

Duff-Norton offers all of the components necessary to complete your power transmission system, whether it consists of a single actuator or a multiple actuator arrangement. We offer a complete line of accessories to interconnect two or more actuators and provide permanent synchronization. Duff-Norton's Application Engineers can specify shafts, couplings, pillow blocks, and right-angle miter gearboxes to accommodate any layout. Bellows boots to protect actuator screws from dirt and other contaminants are available for all actuators, to increase life and reduce maintenance requirements.

The following pages outline the basic selection of power transmission components that can be utilized to assemble a system. The tables match the parts to their respective actuator sizes to assist selection.

By letting Duff-Norton be your sole source for actuator system components, you can consolidate your needs on one purchase order, reducing time spent sourcing, pricing, and receiving parts. Should you have questions, contact our customer service representatives. Duff-Norton's extensive experience in actuator systems can provide you with suggestions for the most economical and reliable method to complete your lifting system.

Typical System Arrangements

1.

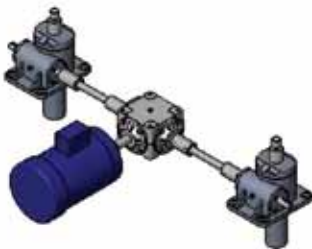

2.

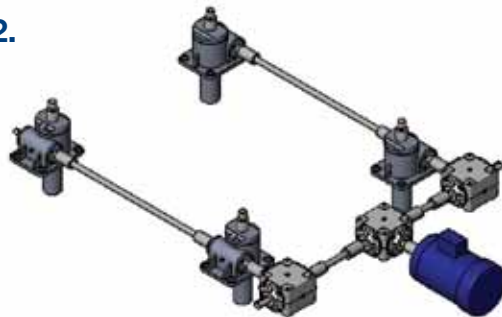

3.

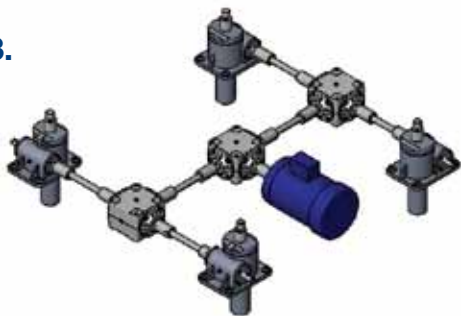

4.

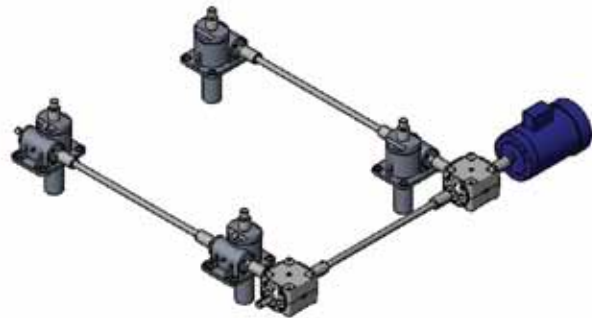

POWER TRANSMISSION COMPONENTS

Machine Screw Power Transmission Components

Actuator Model	Coupling Part #	Bore Size & Description	Connecting Shaft Part #	Pillow Block Part #	Mitre Box Part #	Mitre Box Description	Mitre Box Part #	Mitre Box Description
MS 1/4 Ton	SK2555-29	3/8" Bore - Jaw	SH50	PB50	MB-4	3 way		
MS 1/2 Ton	SK2555-29	3/8" Bore - Jaw	SH63	PB63	MB-4	3 way		
MS 1 Ton	SK2402J	1/2" Bore - Jaw	SH100	PB75	MB-7	3 way		
MS 2 Ton	SK2402J	1/2" Bore - Jaw	SH100	PB100	MB-16	3 way		
MS 3 Ton	CP03-500500	1/2" Bore - Chain	SH100	PB100	MB-16	3 way		
MS 5 Ton	CP05-750750	3/4" Bore - Chain	SH150	PB150	MB-19	3 way	MB-19G	4 way
MS 10 Ton	CP20-10001000	1" Bore - Chain	SH163	PB168	MB-19	3 way	MB-19G	4 way
MS 15 Ton	CP20-10001000	1" Bore - Chain	SH200	PB200	MB-20	3 way	MB-20G	4 way
MS 20 Ton	CP20-10001000	1" Bore - Chain	SH200	PB200	MB-20	3 way	MB-20G	4 way
MS 25 Ton	CP35-13751375	1 3/8" Bore - Chain	SH225	PB225	MB-20	3 way	MB-20G	4 way
MS 35 Ton	CP35-13751375	1 3/8" Bore - Chain	SH250		MB-22	3 way	MB-22G	4 way
MS 50 Ton	CP50-15001500	1 1/2" Bore - Chain	**Please contact our customer service team**					

Anti-Backlash Power Transmission Components

Actuator Model	Coupling Part #	Bore Size & Description	Connecting Shaft Part #	Pillow Block Part #	Mitre Box Part #	Mitre Box Description	Mitre Box Part #	Mitre Box Description
AB 1/4 Ton	SK2555-29	3/8" Bore - Jaw	SH50	PB50	MB-4	3 way		
AB 1/2 Ton	SK2555-29	3/8" Bore - Jaw	SH63	PB63	MB-4	3 way		
AB 1 Ton	SK2402J	1/2" Bore - Jaw	SH100	PB100	MB-7	3 way		
AB 2 Ton	SK2402J	1/2" Bore - Jaw	SH100	PB100	MB-16	3 way		
AB 3 Ton	CP03-500500	1/2" Bore - Chain	SH100	PB100	MB-16	3 way		
AB 5 Ton	CP05-750750	3/4" Bore - Chain	SH150	PB150	MB-19	3 way	MB-19G	4 way
AB 10 Ton	CP20-10001000	1" Bore - Chain	SH163	PB168	MB-19	3 way	MB-19G	4 way
AB 15 Ton	CP20-10001000	1" Bore - Chain	SH200	PB200	MB-20	3 way	MB-20G	4 way
AB 20 Ton	CP20-10001000	1" Bore - Chain	SH225	PB225	MB-20	3 way	MB-20G	4 way
AB 25 Ton	CP35-13751375	1 3/8" Bore - Chain	SH225	PB244?	MB-20	3 way	MB-20G	4 way
AB 35 Ton	CP35-13751375	1 3/8" Bore - Chain	SH250		MB-22	3 way	MB-22G	4 way
AB 50 Ton	CP50-15001500	1 1/2" Bore - Chain	**Please contact our customer service team**					

Ball Screw Power Transmission Components

Actuator Model	Coupling Part #	Bore Size & Description	Connecting Shaft Part #	Pillow Block Part #	Mitre Box Part #	Mitre Box Description	Mitre Box Part #	Mitre Box Description
BS 1/2 Ton	SK2555-29	3/8" Bore - Jaw	SH50	PB50	MB-4	3 way		
BS 1 Ton	SK2402J	1/2" Bore - Jaw	SH63	PB63	MB-4	3 way		
BS 2 Ton	SK2402J	1/2" Bore - Jaw	SH100	PB100	MB-16	3 way		
BS 2 Ton*	SK2402J	1/2" Bore - Jaw	SH100	PB100	MB-16	3 way		
BS 3 Ton	CP03-500500	5/8" Bore - Chain	SH100	PB100	MB-16	3 way		
BS 5 Ton	CP05-750750	3/4" Bore - Chain	SH125	PB125	MB-19	3 way	MB-19G	4 way
BS 5 Ton*	CP05-750750	3/4" Bore - Chain	SH150	PB150	MB-19	3 way	MB-19G	4 way
BS 10 Ton	CP20-10001000	1" Bore - Chain	SH125	PB125	MB-19	3 way	MB-19G	4 way
BS 10 Ton*	CP20-10001000	1" Bore - Chain	SH163	PB168	MB-19	3 way	MB-19G	4 way
BS 20 Ton	CP20-10001000	1" Bore - Chain	SH163	PB168	MB-20	3 way	MB-20G	4 way
BS 20 Ton*	CP20-10001000	1" Bore - Chain	SH200	PB200	MB-20	3 way	MB-20G	4 way
BS 25 Ton	CP35-13751375	1 3/8" Bore - Chain	SH163	PB168	MB-22	3 way	MB-22G	4 way
BS 50 Ton	CP50-15001500	1 1/2" Bore - Chain	**Please contact our customer service team**					
High Lead Option								

NOTE

All selections are based on the actuator's worm input torque at full load. As the application and load changes, the power transmission components best suited for the application may change as well. In particular, connecting shaft sizes could change depending on the shaft length required, which may also result in changes to the pillow blocks and couplings.

POWER TRANSMISSION COMPONENTS

Stainless Steel Machine Screw Power Transmission Components

Actuator Model	Coupling Part #	Bore Size & Description	Connecting Shaft Part #	Pillow Block Part #	Mitre Box Part #	Mitre Box Description	Mitre Box Part #	Mitre Box Description
SMS 2 Ton	SK2402J	1/2" Bore - Jaw	SH100	PB100	MB-7	3 way		
SMS 3 Ton	CP03-500500	1/2" Bore - Chain	SH100	PB100	MB-16	3 way		
SMS 5 Ton	CP05-750750	3/4" Bore - Chain	SH150	PB150	MB-16	3 way		
SMS 10 Ton	CP20-10001000	1" Bore - Chain	SH150	PB150	MB-19	3 way	MB-19G	4 way
SMS 15 Ton	CP20-10001000	1" Bore - Chain	SH175	PB175	MB-20	3 way	MB-20G	4 way
SMS 20 Ton	CP20-10001000	1" Bore - Chain	SH175	PB175	MB-20	3 way	MB-20G	4 way
SMS 25 Ton	CP35-13751375	1 3/8" Bore - Chain	SH225	PB225	MB-19	3 way	MB-19G	4 way
SMS 35 Ton	CP35-13751375	1 3/8" Bore - Chain	SH225	PB225	MB-22	3 way	MB-22G	4 way
SMS 50 Ton	CP50-15001500	1 1/2" Bore - Chain	**Please contact our customer service team**					

Continuous Duty Power Transmission Components

Actuator Model	Coupling Part #	Bore Size & Description	Connecting Shaft Part #	Pillow Block Part #	Mitre Box Part #	Mitre Box Description	Mitre Box Part #	Mitre Box Description
CD 7511	SK2402J	1/2" Bore - Jaw	SH100	PB100	MB-7	3 way		
CD7515	CP20-10001000	1" Bore - Chain	SH100	PB100	MB-16	3 way		
CD 75151*	CP20-10001000	1" Bore - Chain	SH100	PB100	MB-16	3 way		
CD 7522	CP20-10001000	1" Bore - Chain	SH125	PB125	MB-19	3 way	MB-19G	4 way
CD 75221*	CP20-10001000	1" Bore - Chain	SH150	PB150	MB-19	3 way	MB-19G	4 way
High Lead Option								

NOTE

All selections are based on the actuator's worm input torque at full load. As the application and load changes, the power transmission components best suited for the application may change as well. In particular, connecting shaft sizes could change depending on the shaft length required, which may also result in changes to the pillow blocks and couplings.



Power transmission systems frequently use multiple actuator arrangements. Such systems commonly use mitre boxes to effectively position and equally distribute loads. As the mitre boxes are supplied with 1:1 gear ratios as standard, all motion is synchronous upon system actuation through the main drive shaft.

Features

- 98% average efficiency ratings
- Carburized and case hardened bevel gears
- Alloy steel input/output shafts for greater strength
- Anti-friction bearings on all shafts
- MB-4 and MB-8 models come with lifetime lubrication, stainless steel shafts and aluminum housings

Mitre Box Performance Specifications

Part #	Type	Capacity (inch lbs)	Shaft Diameter
MB-4	3 Way	23	.375"
MB-8	3 Way	97	.75"
MB-16	3 Way	344	.625"
MB-19	3 Way	1400	1.0"
MB-19G	4 Way	1400	1.0"
MB-20	3 Way	3000	1.25"
MB-20G	4 Way	3000	1.25"
MB-22	3 Way	5000	1.375"
MB-22G	4 Way	5000	1.375"

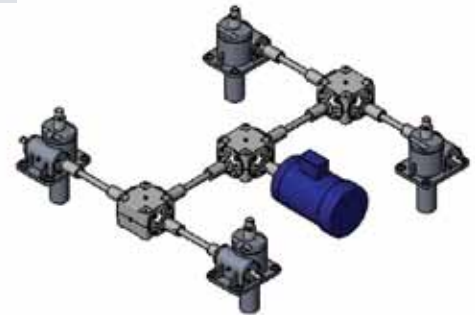

Our mitre boxes feature a compact design, which eliminates the need for an extended hub. With this design feature the bevel gear is supported by tapered roller bearings on both sides. The result is a higher horsepower rating, increased service-life, improved lubrication, and more flexible mounting compared to other brands.



POWER TRANSMISSION COMPONENTS

Mitre Box Dimensional Specifications

Model	Torque	A	B	C	D	E	F	G	H	I	J	K	L	M	N	O	P
MB-4	23	0.375	0.625	0.781	1.313	1.313	1.375	2.750	2.156	FLAT	2.938	0.219	2.156	1.250	0.875	1.188	0.188
MB-8	97	0.750	1.375	1.563	3.000	3.000	3.000	6.000	4.563	3/16"	6.563	0.375	5.000	3.000	2.250	3.000	0.375

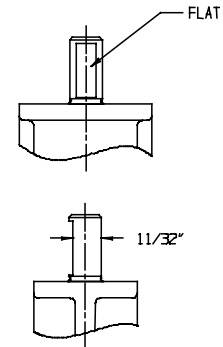
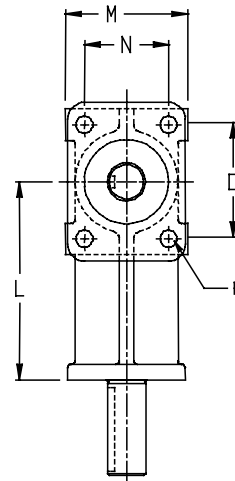
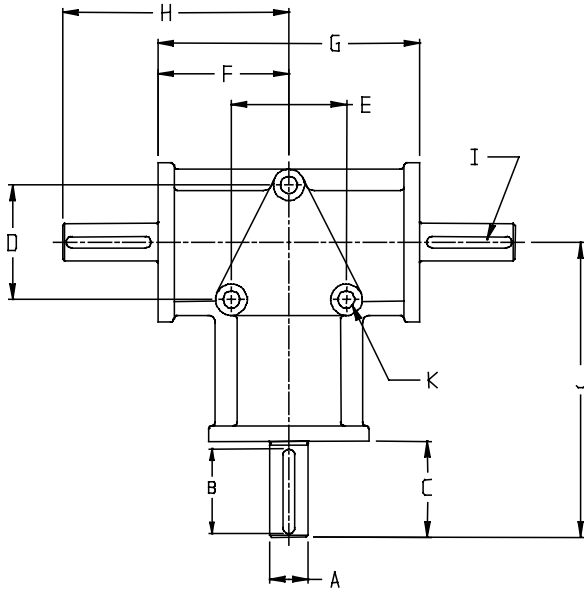

Note: Shaft extensions can be either keyed or flat

Model	Torque	A	B	C	D	E	F	G	H	I	J	K	L	M	N	O	P
MB-16	344	0.625	1.219							1.688	4.875	0.187		3.188	1.594	7.250	3.625

Note: Standard model is a 3-way configuration

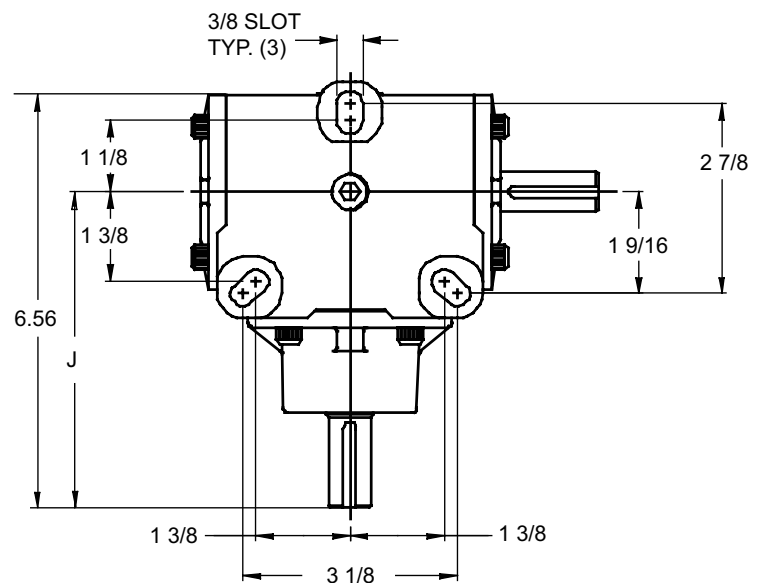
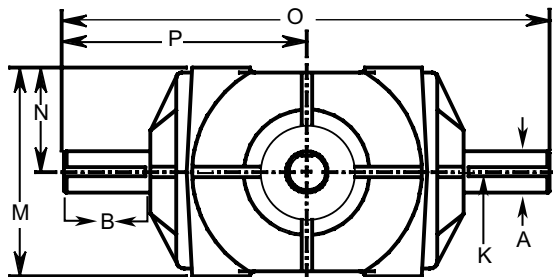

POWER TRANSMISSION COMPONENTS

Mitre Box Dimensional Specifications

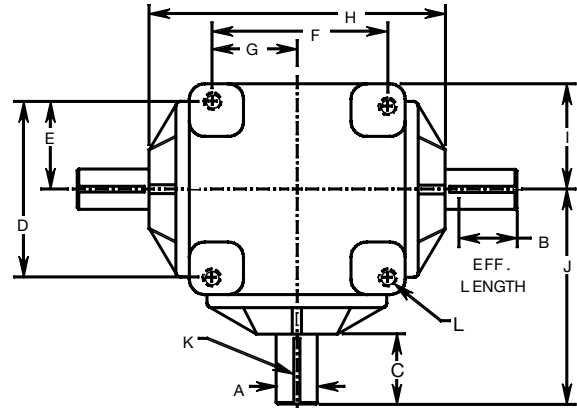
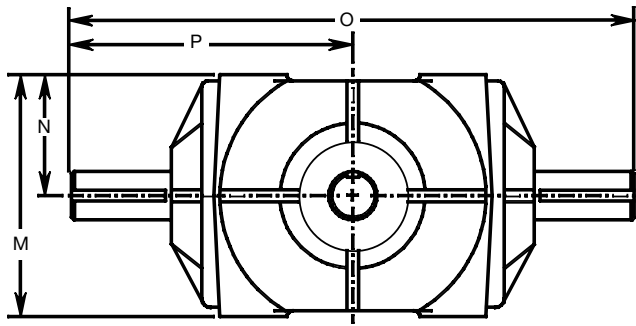

Model	Torque	A	B	C	D	E	F	G	H	I	J	K	L	M	N	O	P
MB-19 (G)	1400	1.000	1.396	2.000	4.250	2.125	4.250	2.125	7.000	2.750	5.500	1/4"	3/8"-16	4.125	2.062	11.000	5.500
MB-20 (G)	3000	1.250	1.840	2.500	4.500	2.250	4.500	2.250	8.000	2.875	6.500	1/4"	1/2"-13	5.625	2.813	13.000	6.500
MB-22 (G)	5000	1.375	2.170	2.938	6.000	3.000	6.000	3.000	10.625	4.125	8.250	5/16"	1/2"-13	7.500	3.750	16.500	8.250

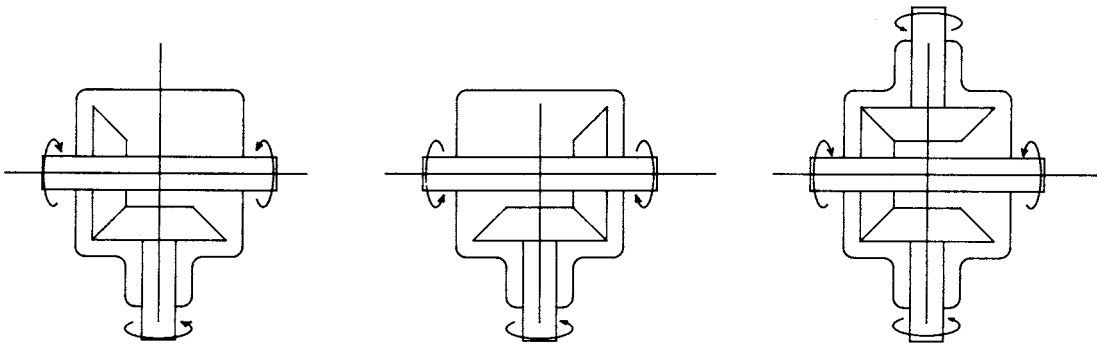

Mitre Box Shaft Rotation

Three and four way Duff-Norton MB series mitre boxes are made for reversible mounting. The relationship between input and output shaft rotation can be reversed by mounting the gearbox upside down.

Two way boxes should be specified as "CW in/CW out" or "CW in/CCW out".

POWER TRANSMISSION COMPONENTS

Actuator Couplings

Duff-Norton provides three coupling types which have been tailored to specific actuator requirements:

Features

Chain Couplings:

- Integrate well with Duff-Norton mid and larger capacity actuators
- High torque capacities
- Standard ANSI dimensions, straight bore diameters
- Common bore diameters may be custom ordered
- Special bore diameters may be custom ordered
- Long service lives
- Easy fit onto the actuator's worm shaft
- Allows for incremental system adjustments

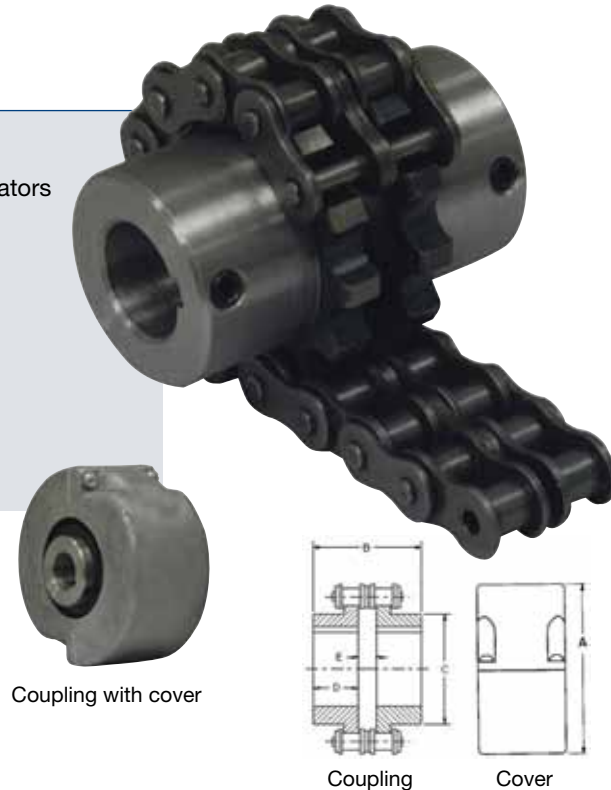

Coupling with cover

Coupling

Cover

Chain Coupling Specifications

Capacity	Part #	Standard Bore***	Maximum Bore	Key Broach Dimensions	A*	B	C	D	E	Act. Torque @ Load**	Coupling Torque	Misalignment (Max) Parallel	Angular
2 Ton	CP03-500500	.500"	.875"	.125" x .63"	4.00"	2.53"	1.41"	1.13"	.28"	132	1354	.015	1/2 deg.
3 Ton	CP03-625625	.625"	.875"	.125" x .63"	4.00"	2.53"	1.41"	1.13"	.28"	181	1354	.015	1/2 deg.
5 Ton	CP05-750750	.750"	1.25"	.1875" x .093"	4.00"	2.53"	1.41"	1.13"	.28"	495	1354	.015	1/2 deg.
10 - 20 Ton	CP20-10001000	1.000"	1.687"	.25" x .125"	5.13"	3.25"	2.50"	1.44"	.38"	2255	4614	.015	1/2 deg.
25 - 35 Ton	CP35-13751375	1.375"	2.000"	.313" x .156"	5.13"	3.75"	2.97"	1.69"	.38"	4400	5969	.015	1/2 deg.
50 Ton	CP50-15001500	1.500"	2.437"	.375" x .1875"	6.38"	4.23"	3.50"	1.88"	.47"	8250	10899	.015	1/2 deg.

*Includes two hubs, four rubber gaskets, chain, and cover

**Based on Anti-backlash actuator torque ratings

***Tolerance for all bores is +.001/-0.000

NOTE: Duff-Norton recommends using the cover assembly with the chain coupling

Coupling Selection Guide

1. Flexible couplings are made up of components. Two hubs each with a bore and keyway to match the shafts being coupled and a chain cover (for chain couplings) or a sleeve kit (for gear-type couplings) or a spider (for jaw-type couplings). The bores in the coupling hubs are sized to give an easy fit on actuator worm shafts.
2. Determine required coupling torque with this formula: Torque Requirement per Actuator X Number of Actuators to Be Driven by the Coupling
3. Verify the required coupling torque. Make sure it's not greater than the maximum rating in the accompanying coupling tables.
4. Chain or full-flex gear couplings are recommended for close coupled arrangements.
5. Chain or flex-rigid gear couplings are recommended for floating shaft arrangements with the rigid hub (if selected) mounted to the floating shaft.
6. For maximum performance, the actuators, shafts, gear boxes and motor should be carefully aligned.

Actuator Couplings

Features

Jaw Couplings:

- Integrate well with Duff-Norton smaller capacity actuators
- Do not require lubrication
- Our Hytrel® spiders provide 2 times the torque capability vs. a standard urethane or BUNA® spider
- Easy fit onto the actuators worm shaft

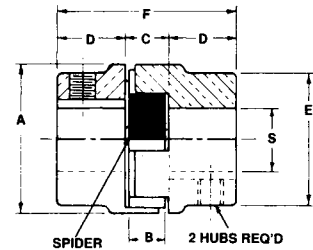

Jaw Type Coupling Specifications

Part #	Standard Bore***	Maximum Bore	Key Broach Dimensions	A*	B	C	D	E	F	Coupling Torque	Misalignment (Max) Parallel	Misalignment (Max) Angular	
SK2555H2	SK2555-29S	.375"	.875"	None	1 5/64	7/16	15/32	5/8	1 5/64	1 23/32	50	.015	1/2 deg.
SK2402J-H1	SK2402-JS	.375"	.875"	.125" x .63"	1 3/4	15/32	1/2	13/16	1 3/4	2 1/8	250	.015	1/2 deg.
SK2402J-H2	SK2402-JS	.626"	.875"	.1875" x .0938"	1 3/4	15/32	1/2	13/16	1 3/4	2 1/8	250	.015	1/2 deg.

*Includes two hubs, and Hytrel spider

**Based on Anti-backlash actuator torque ratings

***Tolerance for all bores is +.001/- .000

Features

Full-Flex and Flex-Rigid Gear Couplings:

- Give great strength under load due to compact design and construction.
- Allow for incremental system adjustment.

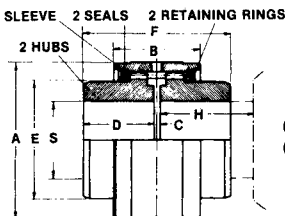

Gear Coupling

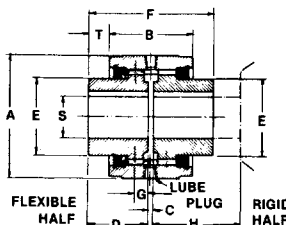

Flex-Rigid Coupling

Gear Coupling Performance Specifications

Capacity	Part #	Standard Bore***	Maximum Bore***	Key Broach Dimensions	A*	B	C	D	E	F	H	Act. Torque @ Load **	Coupling Torque	Misalignment (Max) Parallel	Misalignment (Max) Angular		
5 Ton	SK2405S	SK2405H	SK2404H	.0751	1.25	.1875" x .0938"	3 5/16	2	1/8	1 1/2	2	3 1/8	2 1/8	495	6300	+	1/2 deg.
10 - 20 Ton	SK2410S	SK2410H	SK2409H	1.001	1.25	.25" x .125"	3 5/16	2	1/8	1 1/2	2	3 1/8	2 1/8	2255	6300	+	1/2 deg.
25 - 35 Ton	SK2425S	SK2425H	SK2424H	1.376	1.625	.313" x .156"	3 3/4	2 17/32	1/8	1 13/16	2 3/8	3 3/4	2 21/32	4400	18900	+	1/2 deg.
50 Ton	SK2450S	SK2450H	SK2449H	1.501	1.625	.375" x .1875"	3 3/4	2 17/32	1/8	1 13/16	2 3/8	3 3/4	2 21/32	8250	18900	+	1/2 deg.
100 Ton	SK2499S	SK2499H	SK2498H	1.751	2.125	.50" x .25"	4 3/4	2 9/16	1/8	2 1/16	3 1/4	4 1/4	2 11/16	17600	50000	+	1/2 deg.

*Includes two hubs, and Hytrel spider

**Based on Anti-backlash actuator torque ratings

***Tolerance for all bores is +.001/- .000

POWER TRANSMISSION COMPONENTS

Connecting Shafts

Problem Scenario

A common system operating problem stems from connecting shafts made from standard steel, which are often bowed or out-of-round. This results in a whipping effect while the system is being run with the connecting shaft working its way loose from the system at high speeds and doing a great deal of damage to the system's equipment.

Solution

Duff-Norton connecting shafts, which are furnished with close tolerance Turned, Ground, and Polished steel for smooth rotation.

Features

- Turned, Ground, and Polished steel
- Shaft material is machined from cold-drawn bar
- Furnished with ANSI-standard in-line keyways
- Coordinates well with Duff-Norton Couplings (pages 140-141) and Block Supports (pages 144-145)

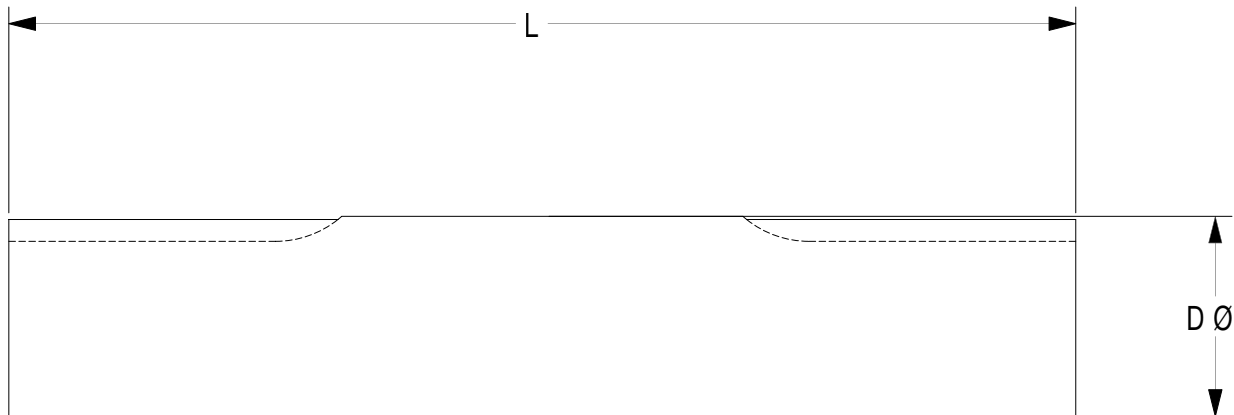

Dimensions and Minimum Size

Model	SH50	SH63	SH75	SH100	SH125	SH150	SH163	SH175	SH200	SH225	SH250	
Minimum Shaft Length* "L" (in.)	5	5	5	5	6	7	7	7	8	10	10	
Shaft Diameter "D" (in.)	Nominal	1/2	5/8	3/4	1	1 1/4	1 1/2	1 5/8	1 3/4	2	2 1/4	2 1/2
	Actual	0.500	0.625	0.750	1.000	1.250	1.500	1.625	1.750	2.000	2.250	2.500
Keyway Width (in.)	1/8	3/16	3/16	1/4	1/4	3/8	3/8	3/8	1/2	1/2	5/8	
Keyway Flat (in.)	1.25	1.25	1.25	1.25	1.5	1.75	1.75	2	2	2.5	2.5	

Note: Minimum shaft length may vary depending on the specified coupling.

POWER TRANSMISSION COMPONENTS

Shaft Selection Criteria

Instructions:

1. Find a torque value that is greater than or equal to your calculated torque requirements.
2. Use the second column to find the required shaft diameter (rounding up is recommended.)
3. Check the third column for the maximum allowable shaft span before supports are required.
4. Match your selected shaft's maximum allowable speed (rpm) to actual shaft speed (rpm). Increasing your selected shaft size is recommended until it falls into the allowable range.



Typical Shaft Torque (Inch/Lbs.)	Nominal Shaft Diameter* (Inches)	Maximum** Distance Between Supports (Inches)	RPM's Not to Exceed ***										
			Typical Shaft Lengths: (Inches)										
			36	48	60	72	84	96	108	120	132	144	156
20	0.51	54.60	1802	1014	649	450	331	253	200	162	134	113	96
40	0.73	61.30	2143	1205	771	536	394	301	238	193	159	134	114
50	0.81	65.50	2372	1334	854	593	436	333	264	213	176	148	126
80	0.87	68.80	2548	1433	917	637	468	358	283	229	190	159	136
100	0.92	71.40	2695	1516	970	674	495	379	299	243	200	168	143
150	1.01	76.30	2982	1677	1074	746	548	419	331	268	222	186	159
200	1.09	80.10	3204	1802	1154	801	589	451	356	288	238	200	171
250	1.15	83.10	3388	1906	1220	847	622	476	376	305	252	212	180
300	1.21	85.70	3546	1995	1277	887	651	499	394	319	264	222	189
350	1.25	87.90	3686	2073	1327	921	677	518	410	332	274	230	196
400	1.30	89.90	3811	2144	1372	953	700	536	423	343	283	238	203
450	1.34	91.70	3925	2208	1413	981	721	552	436	353	292	245	209
500	1.37	93.30	4029	2266	1451	1007	740	567	448	363	300	252	215
600	1.44	96.20	4217	2372	1518	1054	775	593	469	380	314	264	225
700	1.49	98.70	4383	2465	1578	1096	805	616	487	394	326	274	233
800	1.54	100.90	4532	2549	1631	1133	832	637	504	408	337	283	241
900	1.59	102.90	4667	2625	1680	1167	857	656	519	420	347	292	249
1000	1.63	104.70	4792	2695	1725	1198	880	674	532	431	356	299	255
1250	1.72	108.70	5067	2250	1824	1267	931	712	563	456	377	317	270
1500	1.80	112.00	5303	2983	1909	1326	974	746	589	477	394	331	282
1750	1.92	114.90	5511	3100	1984	1378	1012	775	612	496	410	344	293
2000	1.94	117.50	5698	3205	2051	1425	1047	801	633	513	424	356	303
2250	2.00	119.80	5869	3301	2113	1467	1078	825	652	528	437	367	313
2500	2.05	122.00	6025	3389	2169	1506	1107	847	669	542	448	377	321
3000	2.15	125.70	6306	3547	2270	1577	1158	887	701	568	469	394	336
3250	2.19	127.40	6434	3619	2316	1608	1182	905	715	579	479	402	343
3500	2.23	129.00	6554	3687	2359	1639	1204	922	728	590	487	410	349
4000	2.31	131.90	6776	3812	2440	1694	1245	953	753	610	504	424	361
4500	2.38	134.50	6979	3926	2512	1745	1282	981	775	628	519	436	372
5000	2.44	136.90	7165	4030	2579	1791	1315	1008	796	645	533	448	382
6000	2.55	141.10	7499	4218	2700	1875	1377	1055	833	675	558	469	399
7000	2.65	144.80	7794	4384	2806	1949	1432	1096	866	701	580	487	415

Note: Shaded area exceeds maximum distance between supports. Additional support is required.

* Shaft diameter is based on 0.08 degrees twist per foot of length.

** Maximum distance between supports is based on a maximum allowable deflection of 0.01 inches per foot of length.

*** Maximum allowable RPM's is based on 80% of critical shaft speed.

POWER TRANSMISSION COMPONENTS

Actuator Pillow Blocks

Duff-Norton provides a wide assortment of Pillow Blocks designed to operate with our actuators, shafts, and couplings meeting a wide range of system requirements. Pillow Blocks may be used in any shafting configuration for additional shaft support, but are specifically required when the shaft length exceeds the dimensions listed in our shaft selection tables.

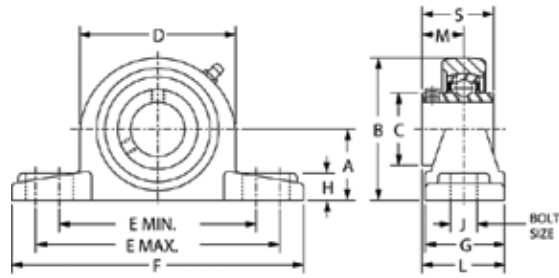

Features

- Ductile iron housing - for extra strength vs. the standard gray iron.
- Setscrew locks - to properly secure the connecting shaft regardless of direction.
- Anti-Rotation Pins - to help prevent random bearing movement.

For more Pillow Block information please see the table below

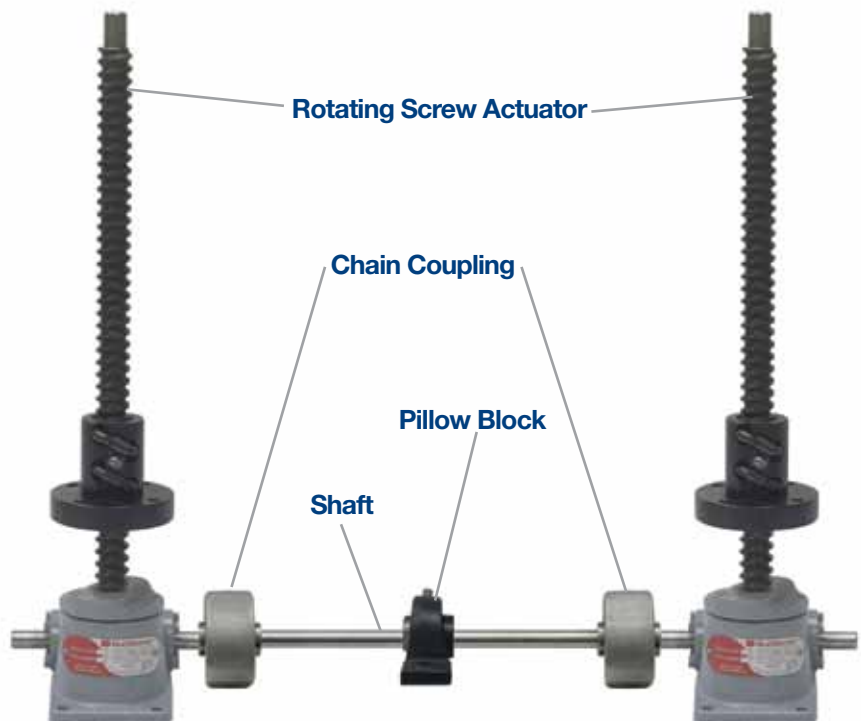

Part #	Diameter	A	B	C	D	E Min.	E Max.	F	G	H	J	L	M	S	Wt. Lbs.
PB50C	1/2	1 1/16	2 1/8	.969	2 1/4	3 3/8	3 5/8	4 3/4	1 3/8	33/64	3/8	1 5/16	.626	1.079	1.2
PB63C	5/8	1 1/16	2 1/8	.969	2 1/4	3 3/8	3 5/8	4 3/4	1 3/8	33/64	3/8	1 5/16	.626	1.079	1.2
PB75C	3/4	1 1/4	2 1/2	1.142	2 5/8	3 3/4	3 31/32	5 1/32	1 1/2	35/64	3/8	1 15/32	.720	1.220	1.9
PB100C	1	1 5/16	2 5/8	1.339	2 25/32	4	4 1/4	5 1/2	1 9/16	19/32	3/8	1 9/16	.776	1.339	2.4
PB125C	1 1/4	1 13/16	3 19/32	1.843	3 27/32	4 13/16	5 3/16	6 9/16	1 7/8	45/64	1/2	1 15/16	1.00	1.689	3.8
PB150C	1 1/2	1 15/16	3 27/32	2.063	4 3/16	5 5/16	5 11/16	7 1/8	2 1/16	3/4	1/2	2 7/32	1.189	1.937	4.8
PB168C	1 11/16	2 1/16	4 1/8	2.260	4 17/32	5 9/16	5 15/16	7 7/16	2 1/8	25/32	1/2	2 1/4	1.189	1.937	5.4
PB175C	1 3/4	2 1/16	4 1/8	2.260	4 17/32	5 9/16	5 15/16	7 7/16	2 1/8	25/32	1/2	2 1/4	1.189	1.937	5.4
PB200C	2	2 7/16	4 27/32	2.705	5 5/16	6 7/8	7 3/8	9 1/8	2 3/8	29/32	5/8	2 1/2	1.315	2.189	8.7
PB225C*	2 1/4	2 11/16	5 11/32	2.949	5 13/16	7 9/32	7 15/16	9 1/2	2 17/32	63/64	5/8	2 25/32	1.528	2.114	10.9
Cast iron housing															

POWER TRANSMISSION COMPONENTS

Actuator Flange Blocks

Duff-Norton provides a wide assortment of Flange Blocks designed to operate with our rotating type Machine Screw, Ball Screw, and Continuous Duty actuators. Flange Blocks lock on to the end of the rotating screw, and can then be bolted on to the machine or fixture. This ensures that the load being carried by the actuator's lifting nut is properly guided.

Features

- Ductile iron housing - for extra strength vs. the standard gray iron.
- Setscrew locks - to properly secure the connecting shaft regardless of direction.
- Anti-Rotation Pins - to help prevent random bearing movement.



For more Flange Block information please see the table below

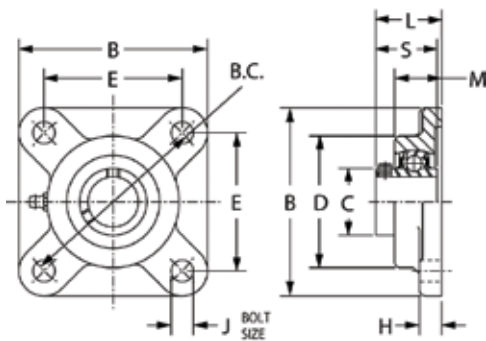

Flange Block

Rotating Screw Actuator

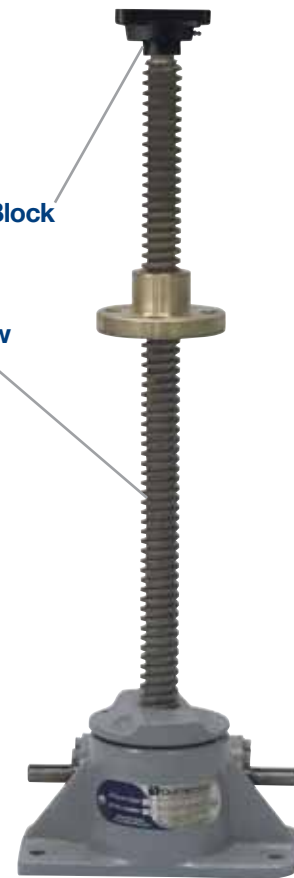

Part #	Rotating Actuator	Shaft Size	B	B.C.	C	D	E	H	J	L	M	S	Wt.Lbs.
FB50C	MS and BS up to 1 Ton	1/2	3	3	.969	2 3/32	2 1/8	7/16	3/8	1 7/32	31/32	1.079	1.0
FB63C	2 Ton MS	5/8	3	3	.969	2 3/32	2 1/8	7/16	3/8	1 7/32	31/32	1.079	1.0
FB75C	2 and 3 Ton BS	3/4	3 3/8	3 5/8	1.142	2 3/8	2 1/2	19/32	3/8	1 15/32	1 5/32	1.220	1.5
FB87C	3 Ton MS	7/8	3 21/32	3 57/64	1.339	2 3/4	2 3/4	19/32	7/16	1 17/32	1 3/16	1.399	1.9
FB100C	5 Ton MS, 5-10Ton BS	1	3 21/32	3 57/64	1.339	2 3/4	2 3/4	19/32	7/16	1 17/32	1 3/16	1.399	1.9
FB125C	10 Ton MS	1 1/4	4 9/16	5 1/8	1.843	3 9/16	3 5/8	11/16	1/2	1 27/32	1 3/8	1.689	4.4
FB150C	15 Ton MS	1 1/2	5 3/32	5 43/64	2.063	4 1/32	4	11/16	1/2	2 1/8	1 17/32	1.937	5.6
FB175C	20 Ton MS & BS	1 3/4	5 5/16	5 27/32	2.260	4 1/4	4 1/8	23/32	1/2	2 1/8	1 9/16	1.937	6.0
FB225C*	25 Ton BS	2 1/4	6 29/32	7 31/32	2.949	5 5/16	5 5/8	23/32	5/8	2 43/64	1 57/64	2.114	11.9
Cast iron housing													

POWER TRANSMISSION COMPONENTS

Bellows Boots

Duff-Norton highly recommends the use of a bellows boot for most actuator applications. Duff-Norton can provide bellows boots for the most stringent application requirement.



Features

- Protects the lifting screw from: dust, dirt, moisture, and corrosive contaminants.
- Helps maintain the proper lubrication.
- Can be provided for all actuator screw end types and configurations.
- Standard bellows boots are made of neoprene coated nylon with sewn construction.
- Special bellows boots can be provided with a variety of materials for applications involving high temperatures, highly corrosive atmospheres, and other special conditions.
- Bellows boots can also be provided from molded materials, with internal or external guides to prevent sagging, and with zippers for easy installation or removal.

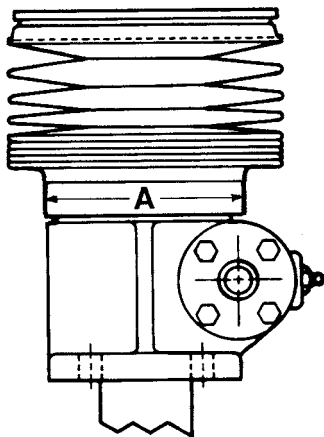

Shell Cap Dimensions

Actuator Capacity	Shell Cap Diameter "A"
1/4 Ton MS	2 1/4
1/2 Ton MS	2 1/4
1 Ton MS	2 3/4
2 Ton MS	3 1/2
3 Ton MS	3 9/16
5 Ton MS	4 1/2
10 Ton MS	5 1/4
15 Ton MS	5 5/8
20 Ton MS	6
25 Ton MS	7 1/2
35 Ton MS	7 7/8
50 Ton MS	11 1/4
75 Ton MS	13 1/4
100 Ton MS	10
150 Ton MS	10
250 Ton MS	16

Actuator Capacity	Shell Cap Diameter "A"
1/2 Ton BS	2 1/4
1 Ton BS	2 3/4
2 Ton BS	3 1/2
3 Ton BS	3 1/2
5 Ton BS	5 3/8
10 Ton BS	4 1/2
20 Ton BS	7
25 Ton MS	8 7/8
50 Ton MS	9 1/2



Closed Height When Optional Bellows Boots are Required on Standard Upright Actuators

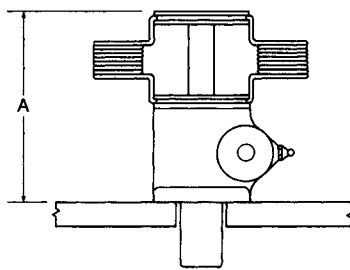

TOP PLATE

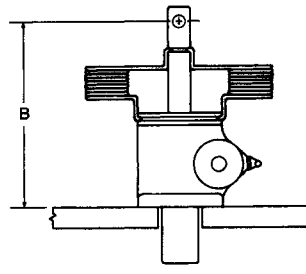

CLEVIS END

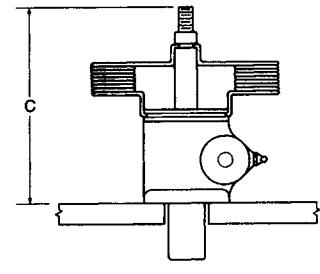

THREADED END

Machine Screw Closed Heights - Upright

Actuator Capacity	Boot O.D.	Raise up to 12"			Raise - 12" to 18"			Raise - 18" to 24"			Raise - 24" to 30"			Raise - 30" to 36"			Raise - 36" to 48"			Raise - 48" to 60"			Raise - 60" to 72"		
		A	B	C	A	B	C	A	B	C	A	B	C	A	B	C	A	B	C	A	B	C	A	B	C
1/4 Ton MS	4 1/4"	4	4	4 1/4	4 3/4	4 5/8	5	—	—	—	—	—	—	—	—	—	—	—	—	—	—	—	—	—	—
1/2 Ton MS	4 1/4"	4	4	4 1/2	4 1/4	4 5/8	4 1/2	4 1/4	4 5/8	4 1/2	—	—	—	—	—	—	—	—	—	—	—	—	—	—	—
1 Ton MS	6"	4 1/2	5	5 3/8	5 1/8	5 5/8	6	5 1/2	5 3/4	6 1/4	—	—	—	—	—	—	—	—	—	—	—	—	—	—	—
2 Ton MS	7 3/4"	5 1/4	6 1/2	7 1/4	5 1/4	7 1/2	8 1/4	5 3/4	7 1/2	8 1/4	5 3/4	7 1/2	8 1/4	6 1/4	8 1/2	9 1/4	—	—	—	—	—	—	—	—	—
3 Ton MS	7 3/4"	5 3/4	6 1/2	6 1/2	6 1/8	7	7	6 5/8	7	7	6 5/8	7	7	6 5/8	7 7/8	8	7 7/8	7 7/8	8	—	—	—	—	—	—
5 Ton MS	7 3/4"	7	7	8	7	8 1/2	9 1/2	7	8 1/2	9 1/2	8	8 1/2	9 1/2	8	10	11	9	10	11	—	—	—	—	—	—
10 Ton MS	9"	7 1/4	8 1/2	9 3/4	7 1/4	8 1/2	9 3/4	7 1/4	9 1/2	10 3/4	8 1/2	9 1/2	10 3/4	8 1/2	9 1/2	10 3/4	9 1/2	10 1/2	11 3/4	10 1/2	11 1/2	12 3/4	11 1/2	12 1/2	13 3/4
15 Ton MS	9"	8	8 1/2	9 3/4	8	10	11 1/4	8	10	11 1/4	9	10	11 1/4	9	10	11 1/4	11	12	12 1/4	11	12	13 1/4	12	13	14 1/4
20 Ton MS	9"	9 1/4	10	11 1/2	9 1/4	11	12 1/2	9 1/4	11	12 1/2	10 1/2	12	13 1/2	10 1/2	12	13 1/2	11 1/2	13	14 1/2	12 1/2	14	15 1/2	13 1/2	15	16 1/2
25 Ton MS	10 3/4"	11	12	13 3/4	11	12	13 3/4	11	13 1/4	15	12	13 1/4	15	12	14 1/2	16 1/4	13	15 3/4	17 1/2	14	15 3/4	17 1/2	15	16 3/4	18 1/2
35 Ton MS	11"	12	13	15	12	13	—	12	13	15	12	13 3/4	15 3/4	12	13 3/4	15 3/4	12 7/8	14 3/4	16 3/4	13 3/4	15 1/2	17 1/2	14 3/4	16 1/2	18 1/2
50 Ton MS	14 1/2"	13	15	17 1/2	13	16	18 1/2	13	16	18 1/2	14	16	18 1/2	14	17	19 1/2	15	18	20 1/2	16	18	20 1/2	17	19	21 1/2
75 Ton MS	16 1/2"	17 1/2	19	21 1/2	17 1/2	19	21 1/2	17 1/2	19	21 1/2	17 1/2	19	21 1/2	17 1/2	19	21 1/2	18 1/2	20	20 1/2	19 1/2	21	23 1/2	20 1/2	22	24 1/2
100 Ton MS	11 1/4"	24	24	25	24	24	25	24	24	25	24	24	25	24 1/2	24 1/2	25 1/2	25	25 1/2	26 1/2	26	26 1/2	27 1/2	27	27 1/2	28 1/2
150 Ton MS	12 1/4"	24	24	25	24	24	25	24	24	25	24	24	25	24 1/2	24 3/8	25 3/8	25	25 1/8	26 1/8	26	26 7/8	26 7/8	27	26 5/8	27 5/8
250 Ton MS	16"	30	—	—	30	—	—	30	—	—	30 1/2	—	—	30 1/2	—	—	31 1/2	—	—	—	—	—	—	32	—

Ball Screw Closed Heights - Upright

Actuator Capacity	Boot O.D.	Raise up to 12"			Raise - 12" to 18"			Raise - 18" to 24"			Raise - 24" to 30"			Raise - 30" to 36"			Raise - 36" to 48"			Raise - 48" to 60"			Raise - 60" to 72"		
		A	B	C	A	B	C	A	B	C	A	B	C	A	B	C	A	B	C	A	B	C	A	B	C
1/2 Ton BS	4 1/2"	—	—	5	—	—	—	—	—	—	—	—	—	—	—	—	—	—	—	—	—	—	—	—	—
1 Ton BS	4 1/4"	—	—	6 1/4	—	—	6 7/8	—	—	7 1/2	—	—	8	—	—	—	—	—	—	—	—	—	—	—	—
2 Ton BS	6 5/8"	—	—	7 1/2	—	—	7 1/2	—	—	7 1/2	—	—	8 1/2	—	—	—	—	—	—	—	—	—	—	—	—
3 Ton BS	6 5/8"	—	—	9 1/4	—	—	9 1/4	—	—	9 1/4	—	—	10 1/4	—	—	10 1/4	—	—	—	—	—	—	—	—	—
5 Ton BS	7 1/2"	—	—	10 3/4	—	—	10 3/4	—	—	10 3/4	—	—	12 1/2	—	—	12 1/2	—	—	—	—	—	—	—	—	—
10 Ton BS	7"	—	—	10 3/8	—	—	10 3/8	—	—	10 3/8	—	—	11 5/8	—	—	11 5/8	—	—	—	—	—	—	—	—	—
20 Ton BS	9"	—	—	16 1/2	—	—	16 1/2	—	—	16 1/2	—	—	16 1/2	—	—	16 1/2	—	—	—	—	—	—	—	—	21 1/2
25 Ton BS	11"	—	—	19 3/4	—	—	19 3/4	—	—	19 3/4	—	—	19 3/4	—	—	21 1/4	—	—	—	—	—	—	—	—	24 1/4
50 Ton BS	12"	—	—	25 3/8	—	—	25 3/8	—	—	25 3/8	—	—	25 3/8	—	—	26 3/8	—	—	—	—	—	—	—	—	28 3/8

Note:(---) indicates "Not Applicable"

POWER TRANSMISSION COMPONENTS

Inverted Machine Screw Actuators

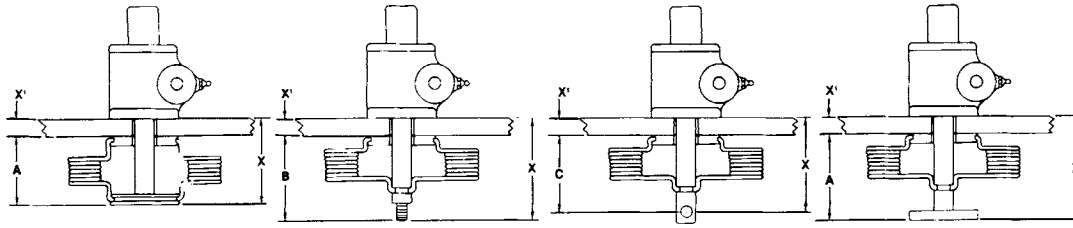

Machine Screw Closed Heights - Inverted

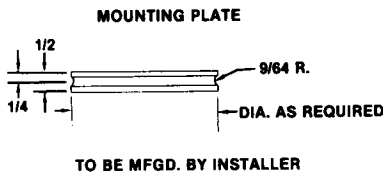

Note: Same values can be used for 4800 and 9400 series actuator units.

Actuator Capacity	Raise up to 6"			Raise - 7" to 12"			Raise - 13" to 18"			Raise - 19" to 24"		
	A	B	C	A	B	C	A	B	C	A	B	C
1/4 Ton MS	2	2 3/8	2	2	2 3/8	2	2 1/8	—	—	—	—	—
1/2 Ton MS	2	2 5/8	2 1/8	2	2 5/8	2 1/8	2 1/8	3 1/4	2 3/4	—	—	—
1 Ton MS	2 1/6	3	2 5/8	2 1/6	3	2 5/8	2 11/16	3 5/8	3 1/4	3 1/16	4	3
2 Ton MS	2 3/8	4 3/8	3 5/8	2 3/8	4 3/8	3 5/8	2 7/8	5 3/8	4 5/8	3	5 3/8	4 5/8
3 Ton MS	2 3/8	3	2 3/4	2 3/8	3 1/2	3 1/4	2 7/8	4	3 3/4	3	4	3 3/4
5 Ton MS	3 3/16	4 3/16	3 3/16	3 3/16	4 3/16	3 3/16	3 3/16	5 11/16	4 11/16	3 1/2	5 11/16	4 11/16
10 Ton MS	3 1/4	5 3/4	4 1/2	3 1/4	5 3/4	4 1/2	3 1/4	5 3/4	4 1/2	3 9/16	7	5 3/4
15 Ton MS	3 1/4	5 1/4	4	3 1/4	5 1/4	4	3 1/4	6 3/4	5 1/2	3 9/16	6 3/4	5 1/2
20 Ton MS	3 1/4	5 9/16	4 1/16	3 1/4	5 9/16	4 1/16	3 1/4	6 9/16	5 1/16	3 1/4	6 9/16	5 1/16
25 Ton MS	3 3/8	6 3/4	5	3 3/8	6 3/4	5	3 3/8	6 3/4	5	3 3/8	7 3/4	6
35 Ton MS	4 1/2	7 1/2	5 1/2	4 1/2	7 1/2	5 1/2	4 1/2	7 1/2	5 1/2	4 1/2	7 1/2	5 1/2
50 Ton MS	4 7/8	9 5/16	6 13/16	4 7/8	9 5/16	6 13/16	4 7/8	10 5/16	7 13/16	4 7/8	10 5/16	7 13/16
75 Ton MS	2 3/8	6 7/8	4 7/8	2 3/4	6 7/8	4 7/8	2 3/4	7 1/2	5 1/2	3 3/8	7 7/8	5 7/8
100 Ton MS	7 11/16	8 11/16	7 11/16	7 11/16	8 11/16	7 11/16	7 11/16	8 11/16	7 11/16	7 11/16	8 11/16	7 11/16
150 Ton MS	7 11/16	8 11/16	7 11/16	7 11/16	8 11/16	7 11/16	7 11/16	8 11/16	7 11/16	7 11/16	8 11/16	7 11/16

Note:

- a. If A = X1 is less than 5 1/2", X=5 1/2"
- b. If B = X1 is less than 9 1/2", X=9 1/2"
- c. If C = X1 is less than 7", X=7"

* If A + X1 and B + X1 are less than 12", X=12". If greater than 12", use the dimensions shown.

**If C + X1 is less than 9", X=9". If greater than 9", use dimensions shown.

Ball Screw Actuators - Inverted

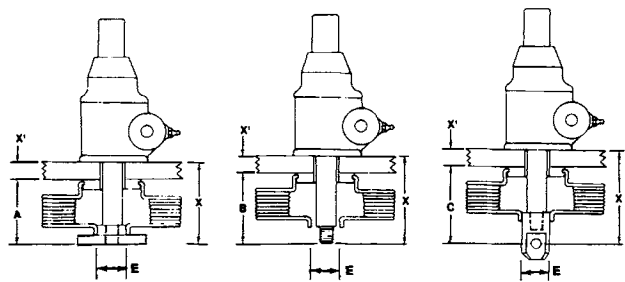

Finding minimum closed dimensions

Add your structure thickness X1 to A, B or C from appropriate chart to find minimum closed dimension. Other styles and sizes of boots can be supplied. In order to use a standard boot, make the mounting plate diameter of the appropriate machine screw or ball screw actuator.

When boots are required for rotating screw jacks, consult Duff-Norton Customer Service.

Ball Screw Closed Heights - Inverted

Actuator Capacity	Raise up to 6"			Raise - 7" to 12"			Raise - 13" to 18"			Raise - 19" to 24"			Std. Boot Collar Dia. E
	A	B	C	A	B	C	A	B	C	A	B	C	
1/2 Ton BS	2	2	2 3/4	2 3/8	2 3/8	3 1/4	2 3/4	2 3/4	3 3/4	3 1/4	3 1/4	4 1/4	0.75
1 Ton BS	2 1/4	2 1/8	2 7/8	3	2 7/8	3 5/8	3 3/4	3 5/8	4 3/8	4 3/8	4 1/4	5	1.25
2 Ton BS	4 3/16	4 5/8	5 1/4	4 3/16	4 5/8	5 1/4	4 3/16	4 5/8	5 1/4	4 3/16	4 5/8	5 1/4	1.50
3 Ton BS	4 3/16	4 5/8	5 1/4	4 3/16	4 5/8	5 1/4	4 3/16	4 5/8	5 1/4	4 3/16	4 5/8	5 1/4	1.50
5 Ton BS	4 3/16	5 1/8	6 1/8	4 5/8	5 1/8	6 1/8	4 5/8	5 1/8	6 1/8	4 5/8	5 1/8	6 1/8	1.75
10 Ton BS	4 3/4	5 1/8	6 1/8	4 3/4	5 1/8	6 1/8	4 3/4	5 1/8	6 1/8	4 3/4	5 1/8	6 1/8	1.50
20 Ton BS	6 3/4	8	9 3/4	6 3/4	8	9 3/4	6 3/4	8	9 3/4	6 3/4	8	9 3/4	2.615
25 Ton BS	5 1/2	6 3/4	9 1/2	5 1/2	6 3/4	9 1/2	5 1/2	6 3/4	9 1/2	5 1/2	6 3/4	9 1/2	3.50
50 Ton BS	7 1/4	7 1/4	10 7/8	7 1/4	7 1/4	10 7/8	7 1/4	7 1/4	10 7/8	7 1/4	7 1/4	10 7/8	4.50

Note: Dimensions subject to change without notice.

Lifetime Warranty

Subject to the conditions stated herein, Duff-Norton will repair or replace, at its option, to the original purchaser without charge, any parts proved to Duff-Norton's satisfaction to have been defective in material or workmanship. Duff-Norton will not repair or replace any parts that become inoperative because of normal repair or modification, improper installation, eccentric loading, overloading, chemical or abrasive action, excessive heat, or other abuse. Equipment and accessories not to Duff-Norton's manufacture are warranted only to the extent that they are warranted by the manufacturer, and only if the claimed defect arose during normal use, applications and service.

EXCEPT AS STATED HEREIN, DUFF-NORTON MAKES NO OTHER WARRANTIES, EXPRESS OR IMPLIED, INCLUDING WARRANTIES OF MERCHANTABILITY AND FITNESS FOR A PARTICULAR PURPOSE.

WARNING

The equipment shown in this catalog is intended for industrial use only and should not be used to lift, support, or otherwise transport people unless you have written statement from the Duff-Norton Company which authorizes the specific actuator unit as used in your applications suitable for moving people.

TERMS AND CONDITIONS

All sales by Seller are made pursuant to the following terms. No other or additional terms or conditions are or will be accepted.

ACCEPTANCE OF ORDERS -

All orders, whether placed directly or through an agent, and all subsequent amendments thereto, are subject to a final approval and acceptance by Seller's main office.

LIMITATION OF WARRANTIES, REMEDIES AND DAMAGES -

THE WARRANTY STATED BELOW IS GIVEN IN PLACE OF ALL OTHER WARRANTIES, EXPRESS OR IMPLIED, OF MERCHANTABILITY, FITNESS FOR A PARTICULAR PURPOSE OR OTHERWISE. NO PROMISE OR AFFIRMATION OF FACT MADE BY ANY AGENT OR REPRESENTATIVE OF SELLER SHALL CONSTITUTE A WARRANTY BY SELLER OR GIVE RISE TO ANY LIABILITY OR OBLIGATION.

Seller warrants that on the date of its delivery to carrier the goods are free from defects in workmanship and materials.

SELLER'S SOLE OBLIGATION IN THE EVENT OF BREACH OF WARRANTY OR CONTRACT OR FOR NEGLIGENCE OR OTHERWISE WITH RESPECT TO GOODS SOLD SHALL BE EXCLUSIVELY LIMITED TO REPAIR OR REPLACEMENT, F.O.B. SELLER'S POINT OF SHIPMENT, OF ANY PARTS WHICH SELLER DETERMINES TO HAVE BEEN DEFECTIVE or if Seller determines that such repair or replacement is not feasible, to a refund of the purchase price upon return of the goods to Seller.

Any action against Seller for breach of warranty, negligence or otherwise must be commenced within one year after such cause of action accrues.

NO CLAIM AGAINST SELLER FOR ANY DEFECT IN THE GOODS SHALL BE VALID OR ENFORCEABLE UNLESS BUYER'S WRITTEN NOTICE THEREOF IS RECEIVED BY SELLER WITHIN ONE YEAR FROM THE DATE OF SHIPMENT.

Seller shall not be liable for any damage, injury or loss arising out of the use of the goods if, prior to such damage, injury or loss, such goods are (1) damaged or misused following Seller's delivery to carrier; (2) not maintained, inspected, or used in compliance with applicable law and Seller's written instructions and recommendations; or (3) installed, repaired, altered or modified without compliance with such law, instructions or recommendations.

UNDER NO CIRCUMSTANCES SHALL SELLER BE LIABLE FOR INCIDENTAL OR CONSEQUENTIAL DAMAGES AS THOSE TERMS ARE DEFINED IN SECTION 2-715 OF THE UNIFORM COMMERCIAL CODE.

TERMS OF PAYMENT -

Unless otherwise stated herein, payment of each invoice is required within thirty (30) days after date of shipment. Any balance unpaid after the required payment date shall be subject to a service charge of 1% per month from such date.

PRICE ADJUSTMENTS -

Amendments made by the Buyer to orders already placed shall, without formal notice to the Buyer, be subject to extra charges. If the estimated shipping date for the goods is more than sixty (60) days after date of order, the price of the goods are subject to increase by Seller.

TAXES -

Any sales, use, excise, and other taxes applicable to this transaction and the goods and/or services furnished by Seller are not included in the price and shall be paid by Buyer when due. If Seller pays any such taxes, Buyer shall reimburse Seller upon demand.

INDEMNIFICATION AND SAFE OPERATION -

Buyer shall comply with and require its employees to comply with directions set forth in instructions and manuals furnished by Seller and shall use and require its employees to follow such instructions and manuals and to use reasonable care in the use and maintenance of the goods. Buyer shall not remove or permit anyone to remove any warning or instruction signs on the goods. In the event of personal injury or damage to property or business arising from the use of the goods, Buyer shall, within forty-eight (48) hours thereafter, give Seller written notice of such injury or damage. Buyer shall cooperate with Seller in investigating any such injury or damage and in the defense of any claims arising therefrom.

If Buyer fails to comply with this section or if any injury or damage is caused, in whole or in part, by Buyer's failure to comply with applicable federal or state safety requirements, Buyer shall indemnify and hold Seller harmless against any claims, loss or expense for injury or damage arising from the use of the goods.

GOVERNING LAW -

This agreement shall be governed by and construed under the laws of the State of New York.

DELIVERY AND DELAYS -

Unless otherwise specified herein, deliveries shall be F.O.B. Seller's point of shipment and risk of loss shall pass to Buyer upon Seller's delivery to carrier. All shipping dates are approximate and Seller shall not be liable for loss or damage because of delays occasioned by labor disputes, damage to facilities, or failure of suppliers or subcontractors to meet scheduled deliveries or any other cause beyond Seller's reasonable control or making its performance commercially impracticable.

Notwithstanding other provisions hereof, if shipment is delayed at Buyer's request, the goods shall be deemed to be stored at Buyer's risk and expense and Seller may thereupon bill Buyer for the full price and storage costs. Buyer shall pay such bill within 30 days after mailing thereof.

BUYER'S INSPECTION UPON RECEIPT OF SHIPMENT -

Buyer shall inspect the goods as soon as received. If any loss or damage is discovered, Buyer must notify both the carrier and Seller at once. Seller will cooperate with Buyer in filing claims with the carrier.

CHANGES AND CANCELLATION -

Seller reserves the right to change or cancel any order whenever circumstances require allocation of production or delivery or Seller deems change or cancellation to be necessary to comply with applicable laws, ordinances, regulations, directives or administrative actions. Seller reserves the right to make changes in materials or design which it determines appropriate for the goods.

SECURITY INTEREST AND REPOSSESSION -

Until full payment has been made therefor, Seller shall have a security interest in goods shipped to Buyer and the goods shall remain personal property. Upon request Buyer shall execute and deliver to Seller security agreements and financing statements further evidencing Seller's security interest. Buyer authorizes Seller to file a financing statement or statements relating to the goods, without Buyer's signature thereon, as Seller may deem appropriate and appoints Seller as Buyer's attorney-in-fact for the limited purpose of executing (without requiring Seller to do so) financing statements in Buyer's name and performing other acts which Seller deems appropriate to perfect and continue its security interest and to protect and preserve the goods.

In the event Buyer defaults in making any payment due Seller, Seller in addition to any other rights or remedies provided by law, shall have the right, with or without legal process, to enter the place where said goods are located and to repossess the goods in accordance with the Uniform Commercial Code.

ASSURANCES -

Shipment by Seller shall at all times be subject to the prior approval of its credit personnel and Seller may, at any time, decline to make shipment except upon receipt of prior payment or upon other terms and conditions or security satisfactory to such personnel.

PATENTS -

Except as to goods manufactured according to design supplied by Buyer, Seller will defend and hold Buyer free and harmless in a suit or proceeding brought against Buyer insofar as it is based on a claim that use of the goods by Buyer constitutes an infringement of any existing U.S. Patents, provided, however, that Buyer gives Seller prompt written notice of such suit or proceeding; permits Seller, through its counsel, to defend and/or settle the same; and gives Seller all necessary information, assistance and authority to enable Seller so to do. If Buyer's use of the goods is held to constitute infringement and further use is enjoined, Seller shall, at its option, either (i) procure for Buyer the right to continue using the goods; or (ii) replace the goods with non-infringing goods; or (iii) modify the goods to non-infringing goods. The foregoing states Seller's entire liability for patent infringement and shall not be construed to render Seller liable for damages based on product output.

MISCELLANEOUS -

This instrument constitutes the entire agreement between Seller and Buyer, superseding all previous understandings and writings regarding this transaction. Any amendment or modification of this Agreement shall be void unless in writing and signed by Seller.

No delay or omission by Seller in exercising any right or remedy hereunder shall be a waiver thereof or of any other right or remedy, and no single or partial exercise thereof shall preclude any other or further exercise thereof or the exercise of any other right or remedy. All rights and remedies of Seller are cumulative.

Sales made pursuant to this Agreement shall be governed by the Uniform Commercial Code as the same may from time to time be construed and in effect in the state wherein Seller has its main office.

ARBITRATION -

All disputes that may arise between the parties regarding the interpretation of the contract and the legal effect of the contract shall, to the exclusion of any court of law, be arbitrated and determined in accordance with the latest Commercial Arbitration Rules of the American Arbitration Association. The arbitration proceeding shall be held in the city in that state where the principal office of the Seller is located. The parties recognize and consent to the above mentioned arbitration association's jurisdiction over each and every one of them.

OTHER PRODUCTS



SuperCylinders



Linear Actuators



**Acme and Ball
Screws & Nuts**



Rotary Unions

Duff-Norton Also Manufactures...



**Acme and Ball
Screws & Nuts**



Linear Actuators



Electric Cylinders



Rotary Unions



P.O. Box 7010 • Charlotte, NC 28241-7010

Phone: (800) 477-5002 • (704) 588-4610

Fax: (704) 588-1994

Email: duffnorton@cmworks.com

www.duffnorton.com

