

Helios: The systems provider in controlled residential ventilation.

MOISTURE PROTECTION



Traditional residential ventilation by opening the windows is not a valid solution these days. Studies have shown that ventilation is only insufficient and uncontrolled in 80% of cases. This destroys the energy savings strived for by the extensive insulating measures. Efficiency, sealed building shells and the ventilation concept for damp and moisture protection require increasingly mechanised, controlled ventilation.

COMFORTABLE CLIMATE



Odours from the kitchen, bathroom and WC as well as harmful substances from cleaning agents, furniture, etc. have to be led away for a comfortable, healthy indoor atmosphere. The moisture caused by cooking, drying and showering – an average of 10-15 litres of water per day in a 4-person household – has to be run outside in order to prevent mould, stains and damp walls.

HEALTHY AIR



Helios has optimal systems for all areas of application, be it with or without heat recovery, for a new build or renovation, multi-storey building or detached house, as a centralised or decentralised solution. Tailored and coordinated accessories round off the corresponding ventilation devices. The requirements of the Energy Saving Ordinance (EnEV) are met in full and fire and noise safety concerns are covered.

Controlled residential ventilation systems at a glance.

PLANNING INFORMATION
DIN 1946-6
DIN 18017-3

44

MULTI-STOREY CONSTRUCTION



MONO TUBE VENTILATION SYSTEM ELS
with individual devices according to DIN 18017-3

46^{on}



CENTRAL VENTILATION SYSTEM ZLS
with energy-saving EC roof fan according to DIN 18017-3

65^{on}

SINGLE FAMILY HOUSES APARTMENTS

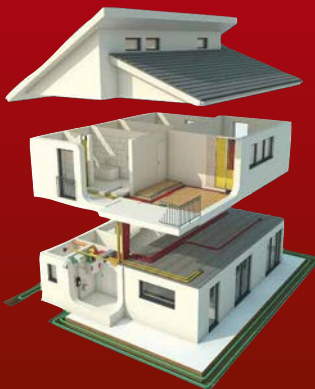

CENTRAL VENTILATION BOX ZEB

70^{on}

KWL® VENTILATION SYSTEMS
with heat recovery

76^{on}

KWL® PERIPHERY

- HygroBox
- Ground heat exchanger
- Air distribution systems
- Air inlets and outlets
- Wall / roof outlets, etc.

114^{on}

■ **Ventilation concept (LK) according to DIN 1946-6**

□ The requirements of the Energy Saving Ordinance (EnEV 2016) for residential buildings prescribe that a minimum user-independent circulation of air in the residential unit must be guaranteed for quality assurance and building protection. For this reason, a ventilation concept is to be created according to DIN 1946-6 for every new build and all energy-oriented refurbishments. The ventilation concept answers the planning issue of whether a residential building is sufficiently ventilated by natural infiltration (building leaks) or whether user-independent ventilation measures are required.

■ **Method:**

1. Calculating the air flow volume for moisture protection according to DIN 1946-6; 05/2009

$$Q_{v,ges,NE,FL} = f_{WS} \cdot (-0,001 \cdot A_{NE}^2 + 1,15 \cdot A_{NE} + 20)$$

$Q_{v,ges,NE,FL}$ = air flow vol. for moisture prot. m³/h
 A_{NE} = Surface area of the residential unit in m²
 f_{WS} = Factor to consider the building's heat insulation.
 0.3 for high insulation (building with insulation according to the German Heat Conservation Ordinance (WSchV) 95 or better).
 0.4 for low insulation (building with insulation worse than WSchV 95).

2. Calculating the air flow volume by infiltration according to DIN 1946-6; 05/2009

$$Q_{v,Inf,wirk} = f_{wirk,Komp} \cdot A_{NE} \cdot H_R \cdot n_{50} \cdot (f_{wirk,Lage} \cdot \frac{\Delta p}{50})^n$$

$Q_{v,Inf,wirk}$ = effective air flow vol. by infiltration m³/h
 $f_{wirk,Komp}$ = Correction factor for deducible system-independent and component-independent infiltration according to DIN 1946-6 Tab. 8, exact calculation according to the calc. method outlined in DIN 1946-6 Annex I. Standard val. 0.5 (taken as a basis to simplify the determination of ventilation tech. measures within the ventilation concept for free ventilation in the form of cross ventilation).
 A_{NE} = Surface area of the residential unit in m²
 H_R = Room height in m
 n_{50} = According to DIN 1946-6 specifications or measured values. See table 1.
 $f_{wirk,Lage}$ = Correction factor for the effective proportion of air from infiltration as a factor of the building location. Standard value 1.0, exact calculation according to the method outlined in DIN 1946-6 Annex I.
 Δp = Differential design pressure
 For single-storey residential units: for areas with little wind 2 Pa, for areas with strong wind 4 Pa.
 For multi-storey residential units: for areas with little wind 5 Pa, for areas with strong wind 7 Pa.
 n = Press. exponent, stand. val. $n = 2/3$ or measured val

3. Air flow volume balancing

Following the calculation of both air flow volumes $Q_{v,Inf,wirk}$ and $Q_{v,ges,NE,FL}$ the two values are compared. If the air flow volume from infiltration is less than the air flow volume for moisture protection, ventilation technology is required. The selected ventilation technology (e.g. Helios DV

EC, ultraSilence® ELS, KWL®) must permanently transport the air flow volumes for moisture protection and must be user-independent (24 hours a day / 365 days a year).

For the further design of a residential ventilation system, it is not only the air flow volume for moisture protection that is relevant, but also the air flow volume needed to fulfil and maintain the minimum hygienic requirements, which must also largely be ensured independently of the users.

■ **Forms of ventilation / operating modes according to DIN 1946-6**

□ **Ventilation for moisture protection (FL)**

Ventilation required to ensure the protection of the building (against moisture) under normal conditions of use with reduced moisture loads in some cases. Example: Normal conditions of use with reduced moisture loads in some cases include, for example, temporary absence of the users and no drying of washing in the residential unit.

Operating mode:

Continuous (24 h/365 d); user-independent

□ **Reduced ventilation (RL)**

Ventilation necessary to ensure the min. hygienic requirements and for the protection of the building (against moisture) under normal conditions of use with reduced moisture loads and subst. concent. in some cases. Example: As a result of the temporary absence of users.

Operating mode:

Continuous (24 h/365 d); user-independent

□ **Nominal ventilation (NL)**

Ventilation necessary to ensure the min. hygienic requirements and for the protection of the building when the users are present (normal operation).

Operating mode: Primarily when users are present; time limited for energy-related reasons; ensured by suitable ventilation technology with temporary support from free ventilation (window ventilation).

□ **Intensive ventilation (IL)**

Temporarily required ventilation with increased air flow volume of air to decompose load peaks (load operation).

Operating mode: Primarily when users are present; time limited for energy-related reasons; ensured by suitable ventilation technology with temporary support from free ventilation (window ventilation).

Table 1: Standard values of design air exchange according to DIN 1946-6

House type	Standard	Ventilation system	n ₅₀ value
Single-storey unit (EFH)	New build	Fan-supported ventilation	1.0
Single-storey unit (EFH)	Renovation	Fan-supported ventilation	1.0
Multi-storey unit (MFH)	New build	Fan-supported ventilation	1.0
Multi-storey unit (MFH)	Renovation	Fan-supported ventilation	1.0
Single-storey unit (EFH)	New build	Free ventilation	1.5
Single-storey unit (EFH)	Renovation	Free ventilation	1.5
Multi-storey unit (MFH)	New build	Free ventilation	1.5
Multi-storey unit (MFH)	Renovation	Free ventilation	2.0

(EFH) = Single family house / (MFH) = Apartment building

■ **Subs. supply of outside air**

A residential ventilation system according to DIN 1946-6 means that a corresponding air flow volume of supply air is subsequently supplied in the amount of the exhaust air flow volumes using suitable outside air vents (ALD) dimensioned according to DIN 1946-6.

Determining the number of outside air vents required in the building shell:

$$n_{ALD} = (q_v - q_{v,Inf,wirk}) / q_{v,ALD}$$

n_{ALD} = Number of outside air vents
 q_v = Air flow vol. of exhaust air per residential unit
 $q_{v,Inf,wirk}$ = Air flow volume from infiltration per residential unit
 $q_{v,ALD}$ = Air flow volume per outside air vent

■ **Noise protection**

DIN 4109 has been established under construction law and governs the noise protection requirements for the building (public/private). In the case of designs according to VOB and terraced or town houses, they must be observed as minimum requirements. They may be agreed for detached house. VDI Directive 4100 has not been established under construction law, but is often regarded as the state of the art. VDI 4100 distinguishes between two levels of noise protection (see table 2).

Framework conditions

The noise levels stated in DIN 4109 can technically be achieved if targeted boundary conditions are observed, such as:

- Manhole arrangement during floor planning
- Design of the installation walls and/or manholes in 220 kg/m³
- Isolation from the main structure
- Determining the noise protection requirements
- Inclusion of an acoustics technician from noise protection level (SSt) III according to VDI 4100
- Contractual safeguarding and determination of the standard principles

Recommendation:

In the case of buildings under private law, it must be defined in advance whether the building is designed according to DIN 4109 or VDI 4100.

■ **Note**

In the case of buildings under private law, it must be defined in advance whether the building is designed according to DIN 4109 or VDI 4100.

www.KWLeasyPlan.de

Table 2: Noise limits (DIN 4109-1)

Sound source	Type of room requiring protection		
	Living rooms, bedrooms	Classrooms, workspaces	
Sound pressure level dB (A)			
Water installations (both water supply and wastewater systems)	$L_{In max} \leq 30^a$	$L_{In max} \leq 35^a$	
Other building service installations	$L_{AF max} \leq 30^b$	$L_{AF max} \leq 35^{b*}$	
Operation	day 6 to 22 hrs	$L_r \leq 35$	$L_r \leq 35$
	night 22 to 6 hrs	$L_r \leq 30$	$L_r \leq 35$

^a Individual short-term peaks when operating the fittings and devices according to Annex B, Table B.1 (Open, close, adjust, interrupt) should be disregarded.

^b With regard to ventilation systems, values which are 5 dB(A) higher are permitted, provided this concerns continuous sounds without any individual tones.

* Unless higher level due to increased intrinsic noise generation is acceptable.

■ **DIN 18017-3 (white paper 09.09) is the recognised state of the art for the planning and installation of ventilation systems in bathrooms and toilets without external windows. Rooms of this kind are widespread in existing multi-storey buildings and are also regularly found in apartment building projects.**

DIN 18017-3 essentially relates to the removal of air from indoor bathrooms and toilets, meaning that it concerns exclusively single rooms. This is in contrast to DIN 1946-6, which relates to the ventilation of apartments in general and therefore considers the entire unit. When planning and implementing the exhaust air system, the first thing to do is to decide whether it relates to a residential or non-residential building.

■ **Process for residential buildings**

Be it a detached house or apartment building, a new build or renovated property, the start of the approach to ventilation technology is the ventilation concept called for by DIN 1946-6. The user-dependent, permanent guarantee of ventilation for damp and moisture protection has specific impacts on the concept design of the exhaust air system.

- The requirements for exhaust air flow volume in accordance with DIN 18017 make a distinction based on the question of whether the air extraction is to be permanent (40 m³/h) or demand-based (60 m³/h). In the case of demand-based systems, the air flow volume may be reduced to 0 in times of low demand for air. Continuous ventilation to protect against moisture, as prescribed in DIN 1946-6, is not stipulated. This means that in two-level ventilation devices are used in exhaust air systems in residential buildings. The basic level (30 m³/h) is connected to the continuous current and cannot be turned off by the user. This therefore sufficiently satisfies the demand for the fan to provide damp and moisture protection. The higher level (60 m³/h or 100 m³/h) is activated according to demand. It is activated when switched on by the user or through moisture/presence control.
- In order to ensure the suitability of an exhaust air system for function also in the case of modern and therefore sealed building shells, the planning and construction of are outdoor air vents are indispensable. The air flow volume of the exhaust air is

to be offset by an equal air flow volume of incoming air through the building shell through suitable outdoor air vents. The infiltration through the building shell previously calculated in the ventilation concept is deducted when determining the dimensions of the ALD.

- In the case of a renovated property, it should be clear to all those involved in the project that the presence of a exhaust air ventilation system in accordance with DIN 18017-3 does not relieve them from their obligation to create and adhere to a ventilation concept according to DIN 1946-6. The air flow volume for damp and moisture protection must in principle be guaranteed. In addition, it is necessary that an air flow volume of incoming flow equal to the total of the air flow volume of exhaust air is continuously passed through the building shell. If the total exhaust air flow volume is smaller than the air flow volume required for damp and moisture protection, the exhaust air ventilation system is to be adjusted at least to the damp and moisture protection air flow volume.

■ **Planning guidelines for exhaust systems**

Building a new residential property:

- Creation of a ventilation concept in accordance with DIN 1946-6
- Design of the controlled ventilation and air extraction in accordance with DIN 1946-6
- Integration of at least two-level individual room fans to ensure ventilation for damp and moisture protection and the air flow volumes required under DIN 18017. Ensuring the supply of further incoming air by selecting suitable outside air vents.

Renovation of a residential property:

- Creation of a ventilation concept in accordance with DIN 1946-6
- Comparison of the exhaust air flow volumes present on-site with the minimum air flow volume for moisture protection
- Retrofitting suitable outdoor air vents, where necessary
- Substitution of the existing single-phase individual room fans by multi-level appliances.

■ **Process for non-residential buildings**

DIN 18017-3 continues to apply beyond its normal scope for the ventilation of interior WCs and other exhaust air rooms in non-residential buildings. In contrast to residential buildings, there are no normative obligations of any kind to ensure ventilation for

damp and moisture protection in non-residential buildings. The need for ventilation technology in WCs in particular is governed by the Workplace Ordinance and other construction law guidelines. The requirements of the standard can be adopted unchanged for ventilation systems in non-residential buildings planned and built in accordance with DIN 18017-3.

■ **Types of system**

- The individual exhaust air ventilation systems are further divided into systems with their own exhaust air duct and systems with a shared exhaust air duct. Due to the numerous benefits (e.g. space-saving by having just one duct), systems with shared exhaust air duct are given preference in practice.
- The central ventilation systems are also divided into two sub-categories: Central ventilation systems with air flow volume that can only be changed jointly and central ventilation systems with air flow volumes that can be changed in each apartment (e.g. DV EC in combination with AE exhaust elements).
- Pure ventilation of individual rooms is within the scope of DIN 18017-3. If there are no requirements on the ventilation technology of any kind in the project within the meaning of DIN 1946-6, the following planned air flow volumes shall apply:
 - 40 m³/h in central ventilation systems
 - This air flow volume is to be discharged permanently.
 - However, the exhaust air flow volume must not be reduced by more than half for more than 12 hours a day in times of low demand for air, particularly at night.
 - 60 m³/h for decentralised exhaust air systems
 - This air flow volume of exhaust air is to be led away during use in the case of demand-based systems.
 - The ventilation appliance may be reduced to 0 in times of low demand for air if the building complies with a thermal insulation standard under the 1995 Heat Insulation Ordinance or better.
 - The same air flow volumes apply for kitchens.
 - In the case of pure WC rooms, these air flow volumes can be halved.

■ **Instructions for project planning**

The primary exhaust air duct should be straight and vertical and must have an even cross-section, otherwise mathematical proof in accordance with DIN 18017-3 is required. The primary

exhaust air duct is to be equipped with heat insulation in order to prevent the formation of condensation. Alternatively, condensation drains may be installed.

- Exhaust air can be carried away from bathrooms and WCs by a fan. To that end, a double direction valve set can be used.
- Exhaust air can be carried away from bathrooms and kitchens via separate fans. The connection of extractor hoods to DIN 18017-3 systems is not permitted. To that end, built-in lines must be planned.
- The exhaust lines are to be permanently sealed and must have a stable design. A sufficient number of suitable cleaning openings are to be provided. Screw-in openings for cleaning are not permitted.

■ **Project planning characteristics for central ventilation systems**

- For central ventilation systems with an air flow volume that can only be changed for all apartments, only exhaust valves with the same characteristic curve can be used. It must not be possible to adjust the valves after adjustment. Systems of this kind are to be operated permanently. Air flow volume reductions in times of low demand for air are to be triggered automatically (e.g. using a timer).
- Central ventilation systems with air flow volumes that can be changed for individual apartments have configurable exhaust elements with variable characteristic curves. The exhaust valves are activated by the user in the apartment or controlled automatically by room air sensors. The air flow volume is then only adjusted according to demand in the respective apartment. Air flow volume stabilizers built into the exhaust elements mean that other apartments remain unaffected by the change. The capacity of the fan adjusts automatically to the total air flow volume to be conveyed.

■ **Fire safety**

The fire safety of exhaust air systems in accordance with DIN 18017-3 is governed in the official ventilation system guidelines (MLüAR), section 7 "Specific conditions for ventilation systems in accordance with DIN 18017-3". All products licensed for this are marked with the label 18017-3 under building law and may only be used in such systems. Use of these fire safety products in other types of systems (e.g. ventilation systems in residential spaces with heat recovery) is not permitted.

Ventilation of sanitary rooms and apartment kitchens in accordance with DIN 18017-3.



The mono tube ventilation system ultraSilence® ELS from Helios has impressive benefits for the ventilation of interior bathrooms and WCs in residential units, hotels and other buildings prescribed by DIN 18017-3.

- **Space-saving:**
A central riser duct spanning more than 20 storeys with the smallest possible cross-section saves money and creates usable living space.
- **Cost-effective:**
Low material use and quick and easy installation result in manageable costs and time required.
- **Energy-saving:**
The ultraSilence® ELS devices reduce the need for ventilation heat and therefore contribute to energy-savings when it comes to heat.
- **Simple planning:**
Evidence of DIBt approval renders all further measurements in the construction sign-off superfluous to requirements, providing extra certainty and saving trouble. The effort for planning, rising duct dimensioning, tendering and specifications is reduced to a minimum.
- **Software-assisted:**
The entire planning is done at the click of a button with Helios ELS software. Lists of materials and offers are completed in just a few steps. Simply download it from www.heliosventilatoren.de.



EXTRACT AIR



The beautifully quiet ELS devices are turned on according to demand and guide used air out of the kitchen, bathroom and toilet via a central main line, which may be connected to more than 20 storeys or over 40 individual devices.

56^{on}

OUTSIDE AIR



External air vents quietly feed outdoor air without dust into bedrooms and living rooms. Helios offers elements that can be built into walls and windows, manually controlled or temperature-regulated, with automatic air flow volume adjustment and sound insulation.

61

FIRE SAFETY



When planning and designing ventilation systems, the state fire safety requirements must be observed. A number of different solutions are available to choose from, depending on the structural circumstances.

55^{on}



Revolutionary and intelligent:
ELS-VF types with automatic
humidity control for optimal en-
ergy saving and a comfortable
room climate without mould.
More on page 53.



Barrier-free and automatic.
ELS-VP with PIR sensor for au-
tomatic ventilation as required
when entering the room. Opti-
mum fan control ideal for toilets
and sanitary facilities of hotels,
offices, hostels, etc.
More on page 53.



Unique: Filter change display in-
dicates when filter needs clean-
ing. Permanent, long life, wash-
able filter with large cross sec-
tion area. Saves the purchase of
expensive disposable filters.



Flexibility without limits: Casing
types ELS-GU and -GUBA for
one/two room ventilation with
connection left, right, to the
bottom or for toilet adaptation.
Discharge spigot to the top,
rotatable to the left, right or to
the back.

The Helios ELS dimension.
Silent. Strong. Slim. Beautiful.



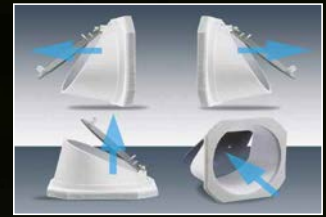

Clever: Airtight back draught shutter in the discharge spigot, can be turned by 90°. Permits casing positioning with discharge to the left, right, to the top or to the back.

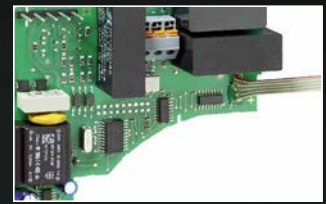

Intelligent electronic system for wide variety of operating modes like interval function, overrun timer, humidity controlled operation, automatic PIR sensor etc. Circuit board with pins for electrical connection placed in splash proof casing.



Efficient energy-saving motor. Acoustically tested, long life ball bearings are greased for life (approx. 40 000 hours running). Maintenance free, totally enclosed in an aluminium diecast casing.



Optimal solution for every demand. More than 20 different ELS fan units can be assembled in the standard surface or flush mounted casing without using tools.



product
design
award
2008



Designpreis
Deutschland
2010
NOMINIERT



red dot
design
award
winner
2008



Design Center
Stuttgart
Silber 2008

ultraSilence
by Helios

- Only 26 dB(A)*. Wonderfully quiet.

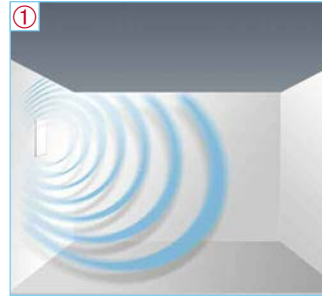

Above all in apartment construction, the ventilation must be virtually silent. This is fully achieved with the single ventilation units ultraSilence® ELS. With 26 dB(A)* for ventilation on the standard ventilation stage ($V=35 \text{ m}^3/\text{h}$) and 35 dB(A)* for $V=60 \text{ m}^3/\text{h}$ and $A_L = 10 \text{ m}^2$, ultraSilence® ELS unbeatably quiet.

The sound levels correspond to DIN 18017-3 as follows and are guaranteed by Helios:
 – sound power level, A-rated (L_{WA}) in dB(A) or
 – sound pressure level, A-rated (L_A) in dB(A) in relation to an absorption surface $A_L = 4 \text{ m}^2$. In relation to $A_L = 10 \text{ m}^2$, so ergethe sound levels are 4 dB(A) lower.

① The sound power level L_{WA} shows the real emitted sound power, independent from the distance and room conditions, and is the sound at source.
 ② The sound pressure level L_A is caused by the source and received by the ear. Depending on absorption, i.e. absorption capacity of the room, the perceived sound varies and is difficult to trace.

* According to DIN 18017-3: 2009-09, section 7.2.4. footnote 5.

- Exclusive. Permanent filter and filter change display.

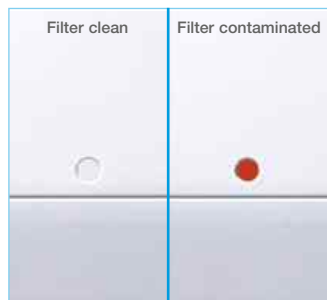

All ELS fan units have **permanent filters as standard**. This ensures trouble free quiet installation. They prevent the fan and sound insulation from becoming clogged, resulting in satisfied tenants, landlords and owners. The filter change display (red dot) indicates when the filter needs cleaning which prevents a drop in performance. Very practical!

User friendly – the retractable facia with hinge.
 For filter removal flip up facia by hand. To close simply let it retract.

Completely airtight.
 The all round flexible sealing prevents air inlet and dirt deposit along the wall/ceiling surface.

Unique – the permanent filter.
 Large filter cross-section area, with high dirt holding capacity for long cleaning intervals. To clean the filter, simply put it in the dishwasher: This eliminates the regular purchase of expensive disposable filters.

- Excellent design. Good-looking. Slim. Clean.



Perfectly designed and multiple award-winning.
 ultraSilence® ELS fits everywhere: The facia complements every tile, wallpaper or marble- and thus satisfies the highest demands of designers. The minimalist-designed ultra flat facia with classy look covers the fan unit. The air flows in on all sides so that dirt deposits are prevented.

The ultra flat premium design of the facade impresses in every room design with unobtrusive elegance. The extremely slimline flush mounted casing has an installation depth of just 89 mm. That way it integrates completely – also in small rooms, on walls or ceilings. The ideal solution, also in narrow installation shafts.



■ **Lightning fast installation.**



Clever. The airtight back draught shutter, which is integrated in the discharge spigot, can be turned by 90°. This makes a positioning of the casing with discharge to the left, right, top or back possible.



Unlimited possibilities. ELS-GU and -GUBA are the universal casings for one or two room ventilation with connection to the left, right or bottom as well as toilet seat adaptation via flushing pipe. The discharge spigot can be positioned to the top, left, right or to the back. Everything with the same casing!



So very simple – the electric plug connection. For trouble-free connection, removable from its fixture. Cable entry and connector connecting takes place with casing assembly. Insertion of fan unit and facia on final fix.

■ **Approved and tested.**



All casings and fan units approved by the DIBt with approval No. Z-51.1-193.

The ultraSilence® ELS units have the approval of the Institute for Bautechnik, Berlin. In addition there are international certificates and conformities with the relevant standards and regulations. There are also the following certificates:

- TÜV approved performance.
- Certificate of the Institute for Acoustics and Building Physics (IAB), Oberursel, for noise transmission regulations in buildings (DIN 4109).
- TÜV approved leakage rate of backdraught shutter.
- External inspection of production by TÜV Bayern-Sachsen.
- Fire protection tests of back draught shutter and casing with fire protection, carried out by the Institute for Material Testing of the Institute for Baustoffe, Mas-sivbau and Brandschutz (IBMB), Braunschweig, swiss fire protection code Z 5491.

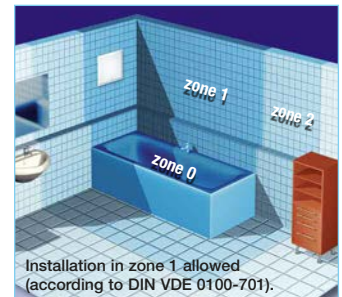

■ **Various operations.**



ELS units are available in approx. 100 variants and 3 airflows for ventilation of kitchen, bathroom and toilet in the apartment sector. User-friendly controls with overrun timer and interval timer function, automatic motion sensor or humidity controlled operation (in standard and demand-based ventilation) for barrierfree automatic operations are optional units.

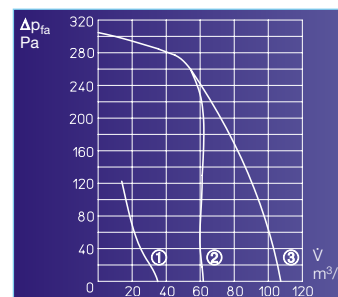

- ① Standard ventilation stage $\dot{V} = 35 \text{ m}^3/\text{h}$
- ② Demand-based ventilation stage $\dot{V} = 60 \text{ m}^3/\text{h}$ or standard ventilation stage for ELS-V 100/..
- ③ Demand-based ventilation stage for ELS-V 100/..

60 m³/h airflow volume at 260 Pa. This pressure capacity puts Helios ELS at the forefront of high-performance fans. This permits the smallest pipe cross sections for the main riser, reduces investment costs and increases the usable living space.

Note
Further information about ELS types for barrier-free automatic operation

- with humidity control
- or PIR detector

see page 53

- **The Energy Saving Ordinance (EnEV 2016) demands the implementation of the low-energy house standard. The altered construction method and the resulting tight building shell place particular significance on the ventilation heat.**

According to the previous design, the ventilation technology is responsible for just 25% of the total energy consumption for heating. Given the sealed thermal building shell, these days this proportion is at least 50% in a modern residential building. Building planning in accordance with EnEV 2016 requires a comparison of a planned residential building with a reference building. A demand-based exhaust air system is standard for a reference residential building in accordance with EnEV 2016. Controlled apartment ventilation using a demand-based exhaust air system has reduced the minimum air exchange for window ventilation from 0,7 h⁻¹ or 0.6 h⁻¹ (with / without leak test) to 0.4 h⁻¹.

The use of Helios VF-AL systems technology can drop the creditable air exchange to as low as 0.35 h⁻¹. This reduction of the minimum air exchange generally lowers primary energy consumption by around 10%. Therefore the requirements for satisfying the KfW requirements (KfW efficient buildings) are significantly easier to fulfill.

- **Helios VF-AL systems technology with moisture-based ventilation control is an optimal solution for the current standard, including in when it comes to pricing.**

It is coordinated over the entire apartment and works according to the principle of vacuum air ventilation.

Exhaust air is taken from the rooms with contaminated air (bathroom, WC, kitchen). Fresh outside air flows through pressure-controlled incoming outside air elements into living rooms and bedrooms

- **Energy-efficiency and demand-optimised control functions are integrated in ELS appliances.**

Sophisticated technology enables demand-based and efficient ventilation according to the property-specific and room-specific tasks.

- **Barrier-free automatic operation** controlled by built-in presence sensors or moisture-controlled function. See adjacent and the right-hand side.

- **What is optimal and when?**

- **Demand-based ventilation with overrun**

Typical use: Ventilation of indoor bathrooms and WCs (overrun prescribed by DIN 18017) with normal frequency of use, e.g. in residential areas.

Applicable devices: Types ELS-VN, ELS-VNC or standard devices with separate overrun switches.

Control: Manual, possibly parallel with light.

- **Demand-based ventilation without overrun**

Typical use: Ventilation of kitchens and rooms with windows. High frequency of use in apartment buildings, hotels, retirement homes and many more.

Applicable devices: All standard ELS-V types

Control: Manual, via conventional installation switches or automatically using a timer.

- **Demand-based ventilation with overrun, presence-controlled or moisture-controlled**

Typical use: For barrier-free automatic operation in bathrooms, toilets and kitchens, as well as rooms with windows.

- **The system components**

- **ELS-VF**

Moisture-controlled exhaust air fan in the bathroom with intelligent moisture progression control to remove excessively high humidity in the air.

The type of increase in moisture is permanently checked by a microprocessor. The ventilation is demand-based and combined with a flow-controlled ELS in the toilet or kitchen.

- **Incoming outside air elements**

Incoming outside air elements for the reliable and efficient supply of incoming air. Types ALEF or ZL are built into window frames or walls.

Exhaust air systems without suitable incoming outside air elements are not suitable for function and do not comply with the state of the art.



- **Applicable devices:**

ELS types ELS-VF and ELS-VP

- **Function / control:**

Automatic, presence-controlled or moisture-controlled ventilation not activated by a switch. See the right hand side for a detailed description.

- **Interval ventilation**

Use: Ventilation of bathrooms and WCs (including interior bathrooms and WCs) with periodical low usage frequency, e.g. in hotel rooms, holiday apartments, student residences.

The adjustable interval and operating times ensure periodic and efficient room ventilation when the rooms are empty. Musty rooms and moisture damage are prevented.

Applicable devices: ELS VNC or standard types in combination with accessory ZNI.

Function: Automatic operation according to defined settings if room is not used. When manually operated (possibly switched in parallel to the light), overrun takes place according to the selected settings.

- **Time-controlled ventilation**

Use: Ventilation of toilets, showers, bathrooms, including rooms in office and administrative buildings, retirement homes, hospitals, etc.

Control: Interval-based or depending on use, i.e. at certain times of day.

- **Standard and demand-based ventilation:**

Ventilation of showers, bathrooms, WCs with high air contamination (e.g. in restaurants, offices).

The continuous, low-noise standard ventilation operation to combat smells and excess moisture. When the room is in use, the system manually switches to high-performance (demand-based level). This is automatically possible during certain times of day using a timer

Applicable devices: All types with 2 or 3 power settings.

Switching: Required for manual DSEL 2 or DSEL 3 operation. We recommend appropriate components for automatic operation.

■ **The top solution for barrier-free automatic operation: Integrated PIR sensor**

Optimal fan control in toilets and sanitary facilities with industrial and private use for example, in hostels, hotels, offices, etc.

- Helios offers the ideal solution: ELS-VP is fitted with a PIR as standard; the fan starts automatically when a person enters the room. The electrical connection is direct to the power supply without need for a switch.

- ELS-VP with motion sensor ventilates automatically as required when entering the room.

- An integrated PIR sensor registers the presence of people and switches on the unit. The unit operates for 15 minutes. If a movement in the room is detected within that time, the operation time is extended respectively.

- When leaving the room, there is a run-on time of 15 minutes.

- Ideally the fan should be fitted so the movement in the room is always detected, so position is important and the PIR sensor should not be hindered by obstructions.

Typical use: Barrier-free, automatic ventilation without using a switch.

Control: PIR controlled.

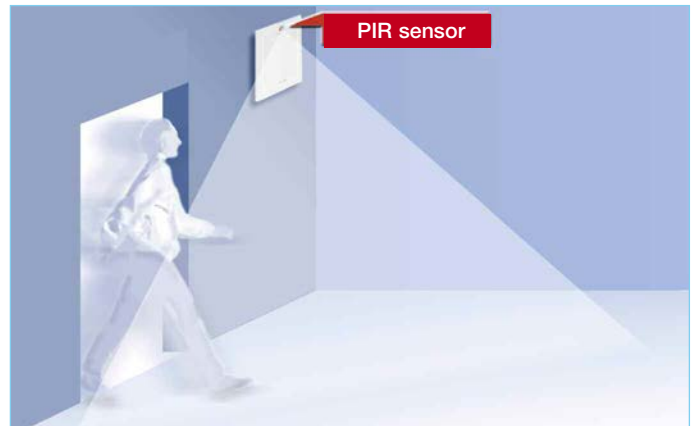
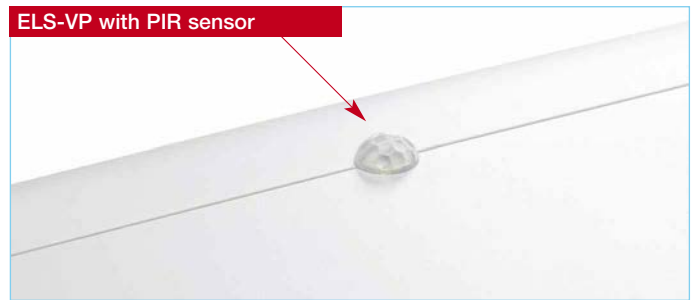

■ **ELS-VF automatic moisture progression system is far superior to conventional humidity switches and prevents the build-up of damp on the walls, ceiling and equipment. It guarantees a healthy climate without mould and bad smells with minimal energy consumption.**

■ **Advanced electronics**

ELS-VFs are equipped with fully-automatic, moisture-dependent controls. The microprocessor-controlled electronics detect two forms of moisture increase:

- Given a normal increase in moisture over time (e.g. washing, drying, temperature drops), the fan switches on when the defined setpoint is reached and runs until the moisture in the room air has dropped by approximately 10%, but at least for the duration of the defined overrun.
- In the case of a rapid increase in moisture (e.g. due to showering, bathing), the ventilator turns on before the defined limit value is reached to get rid of the excess moisture in the room as effectively and quickly as possible. This prevents mirrors or walls from suffering from moisture and damp damage and the comfortable range in the room (40-70%

relative humidity) is quickly re-stored. As soon as the relative humidity has fallen by 10%, but not before the end of the pre-set overrun time, the fan turns off.

- In the case of extended, excessive moisture increases (e.g. storms in summer, damp washing in the room) if air circulation is insufficient as the intake air openings are too small or closed, the fan turns off automatically after two hours of continuous operation. In these cases, the control has identified that further ventilation will not lower the humidity. Depending on the further moisture progression, the fan will start automatically within the next 2 to 6 hours to once again reduce humidity by around 10%. This control behaviour is repeated until humidity has fallen to the desired level.

The moisture progression system automatically adjusts itself to achieve optimal humidity reduction while expending the minimum amount of energy.

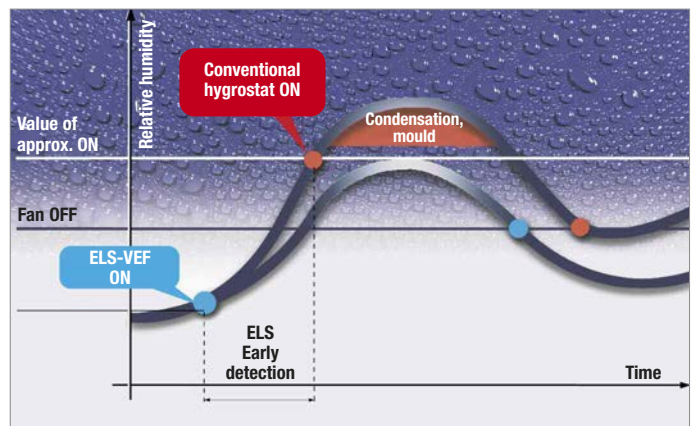

- **Typical use:** For ventilation of humidity polluted rooms (e.g. bathroom, kitchen).
- **Control:** Barrier-free automatic operation, on the humidity levels.
- Supply air is necessary so that humid air can be extracted by the fan.

- The flush mounted casings ELS-GU and -GUBA are totally adaptable in terms of installation position and range of use.
- The standard flush mounted casing ELS-GU and -GUBA, the flush mounted casing with fire protection shutter, is the ideal solution for many different applications.
- Whether for one and two room ventilation or for toilet seat adaptation via flushing pipe. The flush mounted installation is suitable for wall, shaft, plasterboard or ceiling.
- The discharge spigot can be positioned alternatively to the back or on top, also the casing, can be turned by 90° to the left or to the right. Simple and without tools.
- One casing type for every installation form and every ventilation demand. This is not only practical at the building site but also makes stock keeping extremely economical.

See accompanying examples:

- ① One room ventilation
Extraction via facia
- ② Two room ventilation or toilet seat adaptation via flushing pipe
Discharge to the top
- ③ Two room ventilation or toilet seat adaptation via flushing pipe
Discharge to the back

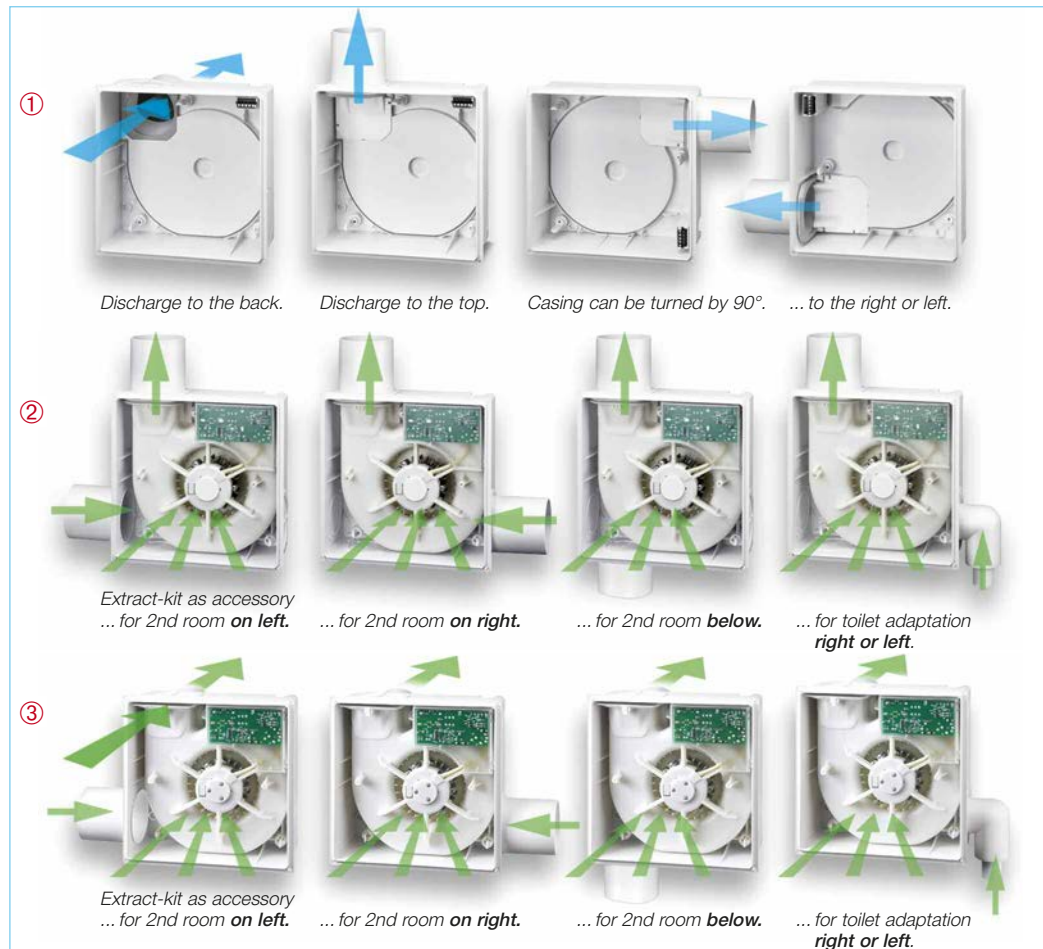

- During the construction of the mono tube ventilation system from Helios professionals were at work. This can be seen above all in many clever assembly details.

■ Trouble-free quick installation

- The universal mounting bracket ELS-MHU brings the necessary flexibility with installation in shafts and false ceilings.
- All flush mounted casings can be easily positioned vertically, in height or perpendicular in a few minutes. ELS-MHU is suitable for the installation of flush mounted casings with and without fire protection encasement.
- On the rear of the casing types ELS-GU and -GUBA embedded turn lock slots for hexagon or square head screws take up the mounting holder which is vertically adjustable as well as in height and depth. Alternatively there are two predetermined breaking points for direct screw connection with elements by customer.
- For plasterboard system integration, the ELS-MB forms the ideal combination with system elements.

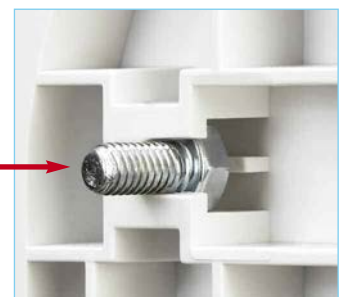
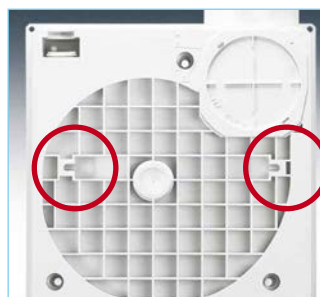
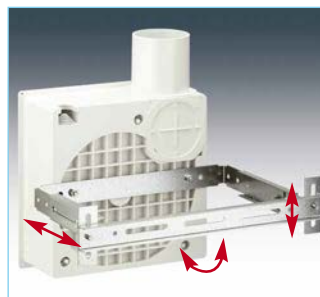

■ Plasterboard adapter ELS-VA

- Simplifies the installation of casing -GU, -GUBA in covered shafts and plasterboards. Make penetration. Mark the square opening with press pins at casing and cut it out. Connect flexible duct with discharge spigot. Make electrical connection. Insert casing with plasterboard adapter room-sided and screw in place. Everything fits in a few minutes!



■ Information about fire protection in buildings

Planning and execution of ventilation systems has to comply with national fire protection requirements. Usually buildings with more than two storeys are subject to such requirements.

In order to prevent fires from spreading to other fire zones, the following solutions can be used for the installation of mono tube ventilation systems depending on structural circumstances:

Flush mounted installation in fire resistant shaft (F90) or L90-ventilation duct.

Applicable casings: Every ELS-GUB casing with fire protection encasement and back draught shutter K90-18017. Steel flexpipe connection for second room connection only.

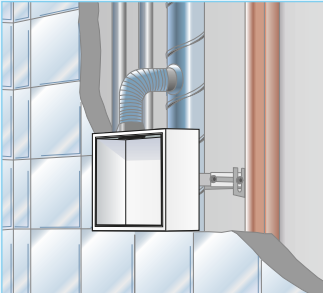
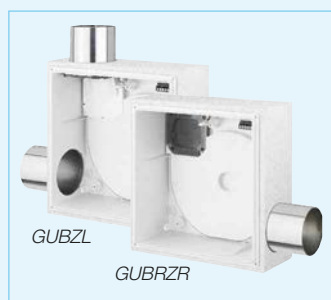
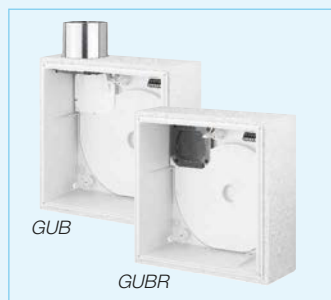
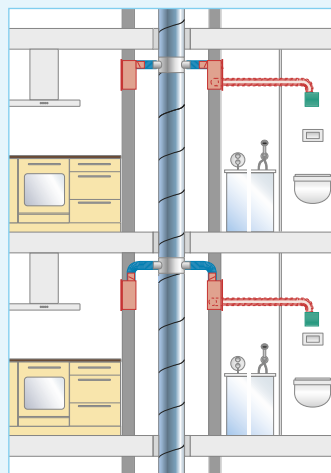
Flush- or surface mounted installation outside of fire resistant shafts (F90) or L90 ventilation ducts

Applicable casings: -GUBA (flush) or -GAPB (surface) with fire protection encasement and back draught shutter K90-18017. Steel flexpipe connection to the main riser.

□ GUBA
The casing ELS-GUBA can be installed in any position (vertical, horizontal) or turned by 90° to the left or right by changing discharge spigot position. Also a discharge to the rear, second room connection or toilet seat adaptation is possible by means of accessories kit.

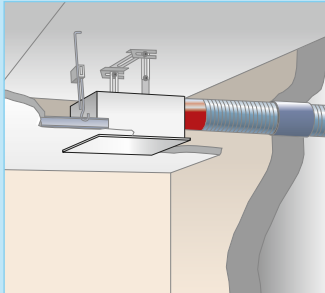
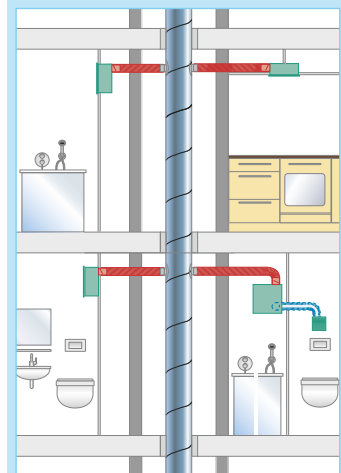
Surface mounted installation on walls of fire resistant shafts (F90) or L90 ventilation ducts.

Applicable casings: ELS-GAPB casing with fire protection encasement and back draught shutter K90-18017.

□ GAPB
The casing ELS-GAPB can be mounted by turning the discharge spigot around 360°, so that the air discharge can be positioned on top left or right and below left or right.

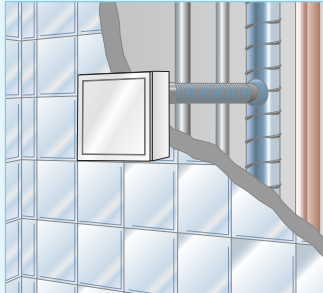
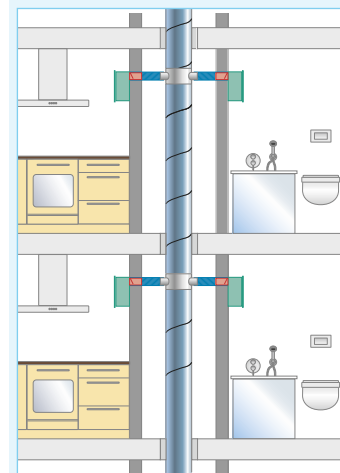
Fire protection solution with fire damper ELS-D



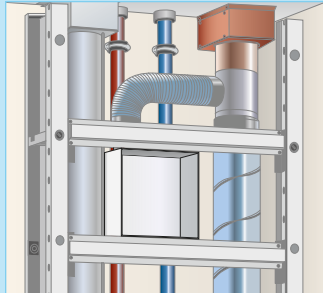
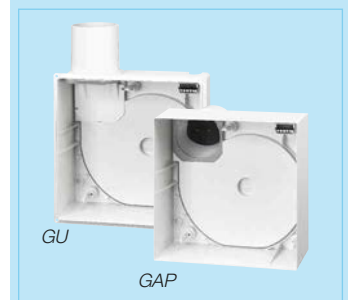
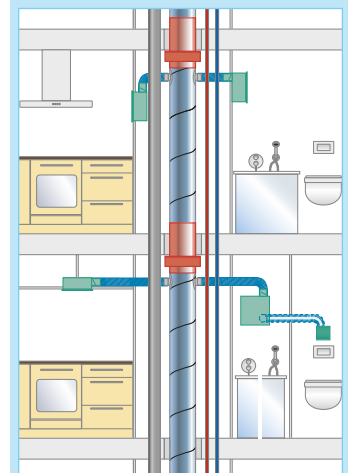

Applicable casings: Universal casing without fire protection ELS-GU for flush mounted or ELS-GAP for surface mounted installation.





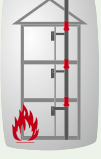

□ Flush mounted casing ELS-GU
ELS-GU can be used like type -GUBA and shown in detail on the page 54 in universal variety.

□ Surface mounted installation ELS-GAP
Installation and positioning like ELS-GAPB, see left.

■ ELS casings without fire protection, for flush and surface mounted installation

with / without fire protection	Casing	Type / Specification	Application	Accessory ¹⁾	Discharge lateral, to the top, left or right	Discharge to the back using accessory ²⁾	One room ventilation	Two room ventilation using accessory ²⁾
 For buildings with up to 2 floors without fire protection.	 	Flush mounted casing without fire protection , with airtight backdraught shutter. Spigot lateral, to the top (as supplied), rotatable to the left or right. Changeable by means of an accessory set ELS-ARS for discharge to the back in any position. Quick plug connector for electrical connection which is removable. Made from polymer (white), fire class B 2. Reinsertable cover plate. Spigot diameter 80 mm. Generally approved by the DIBt with approval no. Z-51.1-193. Type ELS-GU Ref. no. 8111	For ventilation of kitchen*, bathroom or toilet, by means of accessory set also for two room ventilation of bathroom and toilet*. Flush mounted installation in wall, ceiling or shafts. Connection of up to 3 casings per floor is possible. For connection to main duct up to 2 floors without fire protection requirement. With fire protection by the use of fire damper in main duct for more than 20 floors is possible.	•	ELS-ARS Ref. no. 8185	•	ELS-ZS ²⁾ Ref. no. 8186	
	 If fire dampers are used then more than 20 floors	 	Surface mounted casing without fire protection , with airtight backdraught shutter installed in the discharge spigot, for any mounting position and rotatable by 90°. With quick plug connector for electrical connection. With quick plug connector for electrical connection 2. Discharge spigot diameter 80 mm. Generally approved by the DIBt with approval no. Z-51.1-193. Type ELS-GAP Ref. no. 8127	For ventilation of kitchen*, bathroom or toilet. Surface mounted installation in wall or ceiling. Connection of up to 3 casings per floor possible. For connection to main duct up to 2 floors without fire protection requirement. With fire protection by the use of fire damper in main duct for more than 20 floors is possible.	—	•	•	—











■ ELS casings with fire protection shutter, for flush and surface mounted installation

Fire protection	Casings	Type / Specification	Application	Accessory ¹⁾	Discharge lateral, to the top, left or right	Discharge to the back using accessory ²⁾	One room ventilation	Two room ventilation using accessory ²⁾
 for positioning outside of F90 ventilation shaft	 	Flush mounted polymer casing with fire protection shutter K 90, metal discharge spigot with automatic backdraught shutter and shut-off with release of fusible link . Discharge spigot lateral to the top (as supplied), rotatable to the left or right. Changeable by means of an accessory set for discharge to the back in any position. Reinsertable cover plate. Spigot diameter 80 mm. Generally approved by the DIBt with approval no. Z-51.1-193. Type ELS-GUBA Ref. no. 8114	For ventilation of kitchens*, bathroom or toilet. By means of accessory set ELS-ZS also for two room ventilation of bathroom and toilet*. Flush mounted installation in ceiling or wall, as well as outside of K 90-shafts suitably fire rated. Connection of up to 3 casings per floor on more than 20 floors possible.	•	ELS-ARS Ref. no. 8185	•	ELS-ZS ²⁾ Ref. no. 8186	
	 for positioning outside of F90 ventilation shaft	 	Surface mounted casing with fire protection shutter K 90, metal discharge spigot with automatic backdraught shutter and shut-off with release of fusible link . For any mounting position and rotatable by 90°. With quick plug connector for electrical connection. Made from polymer (white), fire class B 2. Discharge spigot diameter 80 mm. Generally approved by the DIBt with approval no. Z-51.1-193. Type ELS-GAPB Ref. no. 8128	For ventilation of kitchens*, bathroom or toilet. Surface mounted wall or ceiling installation. Connection of up to 3 casings per floor on more than 20 floors possible.	—	•	•	—



* For kitchens and two room ventilation of bathroom and toilet use of fan unit with 100 m³/h recommended.



²⁾ Consisting of second room plenum box and spigot for second room connection, see page 60.

¹⁾ Details and specifications to ELS-accessories see page 60.

■ ELS flush mounted casings with fire protection encasement, for one room ventilation				Discharge lateral, to the top, left or right	Discharge to the back	One room ventilation	Extraction unit for 2 rooms (Accessories ¹⁾)
Fire protection	Casings	Type / Specification	Application				
 <p>Casing installation in F90 ventilation shaft</p>		<p>Flush mounted casing with fire protection encasement K 90, Metal discharge spigot with automatic backdraught shutter and shut-off with release of fusible link. Discharge spigot lateral to the top (as delivered), turnable to the left or right. Quick plug connector for electrical connection removable. Reinsertable cover for protection when plastering. Spigot diameter 80 mm. Generally app. by the DIBt with approval no. Z-51.1-193.</p> <p>Type ELS-GUB Ref. no. 8112</p>	<p>For ventilation of kitchen*, bathroom or toilet. wall, ceiling or F90 qualified shafts suitably fire rated. Connection of up to 3 casings per floor on more than 20 floors possible.</p> 	•	—	•	—
		<p>As ELS-GUB, however discharge spigot to the back, rotatable by 90° in any position. For the shortest connection to the main line. Generally approved by the DIBt with approval no. Z-51.1-193.</p> <p>Type ELS-GUBR Ref. no. 8113</p>	<p>As Type ELS-GUB.</p>	—	•	•	—
■ ELS flush mounted casings with fire protection encasement, for two room ventilation							
 <p>Casing installation in F90 ventilation shaft</p>		<p>Flush mounted casing with fire protection encasement K 90 and spigot for second room on the left. Metal discharge spigot with automatic backdraught shutter and shut-off with release of fusible link. Discharge spigot for main room above (as delivered), laterally rotatable to the left or right. Quick plug connector for electrical connection removable. Reinsertable cover plate. Spigot diameter 80 mm. Generally approved by the DIBt with approval no. Z-51.1-193.</p> <p>Type ELS-GUBZL Ref. no. 8115</p>	<p>Two room ventilation of bathroom and toilet*. Installation in wall, ceiling and F90 shafts suitably fire rated. Connection of up to 3 casings per floor on more than 20 floors possible.</p> 	•	—	—	ELS-ZS Ref. no. 8186
		<p>As ELS-GUBZL, however spigot for second room on the right. Generally approved by the DIBt with approval no. Z-51.1-193.</p> <p>Type ELS-GUBZR Ref. no. 8117</p>	<p>As Type ELS-GUBZL.</p>	•	—	—	ELS-ZS Ref. no. 8186
		<p>As ELS-GUBZL, however discharge spigot to the back and rotatable by 90° into any position. Generally approved by the DIBt with approval no. Z-51.1-193.</p> <p>Type ELS-GUBRZL Ref. no. 8116</p>	<p>As Type ELS-GUBZL.</p>	—	•	—	ELS-ZS Ref. no. 8186
		<p>As ELS-GUBZR, however discharge spigot to the back and rotatable by 90° into any position.</p> <p>Type ELS-GUBRZR Ref. no. 8118</p>	<p>As Type ELS-GUBZL.</p>	—	•	—	ELS-ZS Ref. no. 8186

* For kitchens and two room ventilation of bathroom and toilet use of fan unit with 100 m³/h recommended. ¹⁾ Details and specifications to ELS-accessories see page 60. The check valve for fire protection casings fulfills the requirements of a cold smoke shutter.

60 m³/h		60 m³/h air flow volume For bathrooms or toilets		Accessories			
Type	Description	Application	DSEL 2 No. 1306 Speed and operating switch	ZT No. 1277 Time-variable overrun timer	ZNE No. 0342 ZNI No. 0343 Overrun timer	ZV No. 1279 Electronic overrun timer	
ELS-V 60 Ref. no. 8131 	Fan unit with 60 m³/h air flow volume . Delivered complete with flat facia (alpine white) and ultraSilence® technology. With permanent filter and filter control as standard. Integrated quick plug connector for electrical connection. Insulation class II, protection to IP 55, for installation in zone 1 of bathrooms. Maintenance free, energy saving ball bearing motor 230 V~, 50 Hz, 18 W. Sound power 39 dB(A) ¹⁾ , sound pressure 35 dB(A)* ¹⁾ . General technical approval no. Z-51.1-193.	For ventilation of shower, bathroom or toilet. Control manually via the light switch. The overrun which is necessary in windowless rooms is to be provided by means of an overrun timer (accessories).	—	•	•	•	
ELS-VN 60 Ref. no. 8137	As ELS-V 60, but with integrated overrun timer , run on time approx. 6, 15, 21 min. (adjustable), delayed start approx. 45 sec. (non-adjustable).	For ventilation of rooms as previously mentioned. With overrun function for windowless rooms. Control via the light switch.	—	—	—	—	
ELS-VNC 60 Ref. no. 8143	As ELS-V 60, but with adjustable overrun timer and interval operation . Delayed start 0 or 45 sec., run on time 6, 10, 15 or 21 min. and interval time 4, 8, 12 or 24 hours adjustable.	Automatic, periodical ventilation of rooms with low user frequency (hotel, holiday homes). Individually adjustable run over times increase the comfort in the private area.	—	—	—	—	
ELS-VP 60 Ref. no. 8149	As ELS-V 60, but with integrated motion sensor for automatic ventilation when entering the room. Run on time approx. 15 min. Electrical connection is direct to the power supply without need for a switch.	Automatic, PIR controlled ventilation without the need of a switch. Automatically switches on with room occupancy. See page 53 for details.	—	—	—	—	
ELS-VF 60 Ref. no. 8161	As ELS-V 60, but with electronic humidity sensor . Automatic ventilation when set humidity set point is reached, switches off automatically after humidity reduction of approx. 10%. In case of manual operation, delayed start 0 or 45 sec., run on time 6, 10, 15 or 21 min. adjustable.	Ideally for the prevention of damage to the building due to humidity and mould in small, high humidity rooms. Automatically switches on with raised humidity. See page 53 for details.	—	—	—	—	
60/35 m³/h		2 speeds 60/35 m³/h For bathrooms or toilets					
ELS-V 60/35 Ref. no. 8133 	Fan unit with 2 speeds (60/35 m³/h) for standard and demand-based ventilation . Delivered complete with flat facia (alpine white) and ultraSilence® technology. With permanent filter and dirty filter indicator as standard. Integrated quick plug connector for electrical connection. 230 V~, 50 Hz, 18/9 W. Sound power 39/30 dB(A) ¹⁾ , sound pressure 35/26 dB(A)* ¹⁾ . Otherwise as ELS-V 60.	For ventilation of small rooms (shower, bathroom, toilet) with high polluted air. The low speed can be connected for continuous trickle operation. The high speed is then controlled manually via the light switch. Manual control of both speed steps with switch DSEL 2 possible. Run on time by using available accessory.	•	•	—	•	
ELS-VN 60/35 Ref. no. 8139	As ELS-V 60/35, but with integrated overrun timer , run on time approx. 6, 15, 21 min. (adjustable), delayed start approx. 45 sec. (non-adjustable).	As ELS-V 60/35. The built-in overrun timer causes extended operation on high performance level after manual switching off.	•	—	—	—	
ELS-VF 60/35 Ref. no. 8163	As ELS-V 60/35, but with electronic humidity sensor . Standard ventilation at continuous operation. Automatic ventilation when set humidity set point is reached, switches off automatically after humidity reduction of approx. 10%. In case of manual operation, delayed start 0 or 45 sec., run on time 6, 10, 15 or 21 min. adjustable.	Ideal for preventing humidity damage. See page 53 for details. The small step can be used for continuous operation. Large step is automatically activated depending on humidity. Manual control of both steps possible with DSEL 2 switch.	•	—	—	—	

100 m ³ /h		100 m ³ /h air flow volume For bathrooms <u>and</u> toilets or kitchens		Accessories			
Type	Description	Application	DSEL 2 No. 1306 Speed and operating switch	ZT No. 1277 Time-variable overrun timer	ZNE No. 0342 ZNI No. 0343 overrun timer	ZV No. 1279 Electronic overrun timer	
ELS-V 100 Ref. no. 8132 	Fan unit with 100 m³/h air flow volume . Delivered complete with flat facia (alpine white) and ultraSilence® technology. With permanent filter and filter control as standard. Integrated quick plug connector for electrical connection. Insulation class II, protection to IP 55, for installation in zone 1 of bathrooms. Maintenance free, energy saving ball bearing motor 230 V~, 50 Hz, 29 W. Sound power 51 dB(A) ¹⁾ , sound pressure 47 dB(A) ^{*1)} . General technical approval no, Z-51.1-193.	Simultaneous ventilation of bathroom and toilet (flush mounted). Ventilation of domestic kitchens. Overrun function possible with accessories.	—	•	•	•	
ELS-VN 100 Ref. no. 8138	As ELS-V 100, but with integrated overrun timer , run on time approx. 6, 15, 21 min. (adjustable), delayed start approx. 45 sec. (non-adjustable).	Simultaneous ventilation of bathroom and toilet (overrun required by DIN). Ventilation of domestic kitchens.	—	—	—	—	
ELS-VNC 100 Ref. no. 8144	As ELS-V 100, but with adjustable overrun timer and interval operation . Delayed start 0 or 45 sec., run on time 6, 10, 15 or 21 min. and interval time 4, 8, 12 or 24 hours adjustable.	Automatic, periodic ventilation of rooms (also covers two-room ventilation) with irregular use, such as e.g. in hotels, holiday homes. Comfort solution in private sector.	—	—	—	—	
ELS-VP 100 Ref. no. 8150	As ELS-V 100, but with integrated motion sensor for automatic ventilation when entering the room. Run on time approx. 15 min. Electrical connection is direct to the power supply without need for a switch.	Automatic, presence-controlled ventilation without switch operation. Barrier-free with automatic function. See page 53 for details.	—	—	—	—	
100/60/35 m ³ /h		2, 3 speeds 100/60 m ³ /h, 100/60/35 m ³ /h For bathrooms <u>and</u> toilets or kitchens					
ELS-VN 100/60 No. 8141 	Fan unit with 2 speeds (100/60 m³/h) for standard and demand-based ventilation and integrated overrun timer . Run on time approx. 6, 15, 21 min. (adjustable), Delayed start approx. 45 sec. (non-adjustable). Delivered complete with flat facia (alpine white) and ultraSilence® technology. With permanent filter and dirty filter indicator as standard. 230 V~, 50 Hz, 29/18 W. Sound power 51/39 dB(A) ¹⁾ , sound pressure 47/35 dB(A) ^{*1)} . Otherwise as ELS-V 100.	Simultaneous ventilation of bathroom and toilet (flush mounted). Ventilation of domestic kitchens. With near-silent standard ventilation stage. The small performance step can be used for continuous operation. The demand-based ventilation is activated manually by light switch. Manual control of both steps with DSEL 2 switch (accessories).	•	—	—	—	
ELS-V 100/60/35 No. 8136	As ELS-V 100, but with 3 speeds (100/60/35 m³/h) for demand-based and standard ventilation . 230 V~, 50 Hz, 29/18/9 W. Sound power 51/39/30 dB(A) ¹⁾ , sound pressure 47/35/26 dB(A) ^{*1)} .	Medium or small performance step can be used for continuous operation and switched with DSEL 2. Manual 3-step control with DSEL 3.	• or DSEL 3 Ref. no. 1611	•	—	•	
ELS-VF 100/60/35 No. 8166	Fan unit with 3 speeds (100/60/35 m³/h) for demand-based and standard ventilation and with electronic humidity sensor . 230 V~, 50 Hz, 29/18/9 W. Sound power 51/39/30 dB(A) ¹⁾ , sound pressure 47/35/26 dB(A) ^{*1)} . Otherwise as ELS-VF 60/35.	Ideal for preventing humidity damage. See page 53 for details. The small or medium step can be switched with DSEL 2 for continuous operation. Large step is automatically activated depending on humidity. Manual 3-step control with DSEL 3.	• or DSEL 3 Ref. no. 1611	—	—	—	

* at A_L = 10 m² equivalent absorption surface in combination with casing type ELS-GU, side discharge. Information according to DIN 18017-3:2009-09, section 7.2.4. footnote 5.

¹⁾ Noise data for surface installation see table on page 64.

Adaption kit for rear discharge

Type ELS-ARS Ref. no. 8185

For discharge to the rear with all flush mounted casings ELS-GU and -GUBA without fire protection encasement. Simply fit the ARS diverter on the discharge side of the fan unit to ensure a proper air guide.



Toilet extraction kit

Type ELS-WCS Ref. no. 8191

WC-Kit for connection of toilet seat extraction system in combination with room ventilation; for casing types ELS-GU, -GUBA. The connection between casing and flushing tank tube is carried out with customary plastic tubes. Scope of delivery: Cap, bend 90°, two-step spigot Ø 40 and 30 mm.

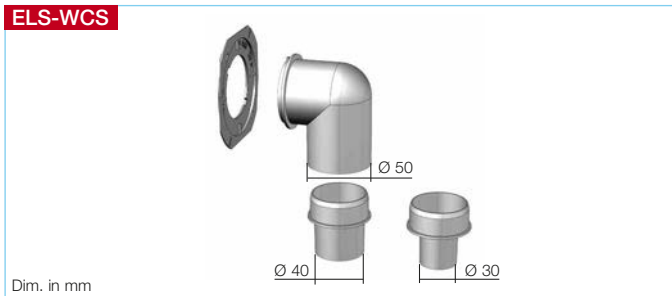

Second room kit

Type ELS-ZS Ref. no. 8186

Inlet air plenum box for flush mounted installation for connection with all casings for second room connection ELS-GU. Design awarded facia in white, with covered front and air inlet on all sides. Integrated, easy accessible air filter. Including second room spigot for casing ELS-GU and -GUBA.



ELS-ZAS



Second room spigot

Type ELS-ZAS Ref. no. 8184

Insert spigot for casing types ELS-GU and -GUBA. For connection of second room ventilation on site. nom. diameter 75/80 mm.

Plasterboard adapter

Type ELS-VA Ref. no. 8189

Makes room-sided casing insertion and installation for flush mounted ELS casings in covered shafts and plasterboards possible. The adapter is bolted with the casing and its frame is fastened with screws to the plasterboard.

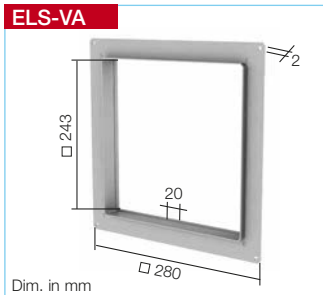

Universal mounting bracket

Type ELS-MHU Ref. no. 8187

Principally for flush mounted casing installation in shafts, especially with casings with fire protection encasement. For fixing on ceilings or walls. Adjustable vertically, in height and perpendicular. Suitable for all flush mounted casings.

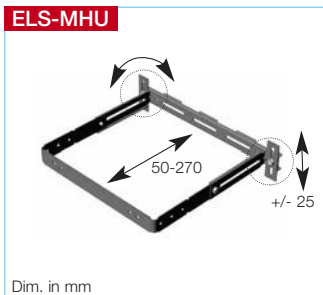

ELS-MB

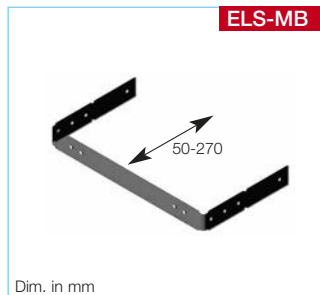

Mounting holder

Type ELS-MB Ref. no. 8188

For integration of flush mounted casings in plasterboard systems in connection with system elements of plasterboard supplier. The mounting holder is simply fixed with hexagon or square head screws to the embedded turn lock slots on the back side of the ELS casing.

Spacer frame

Type ELS-AGR Ref. no. 8193

Covers up to 15 mm of flush-mounted casing, which was not installed level with the plaster or tiles.

The spacer frame is simply fixed between the wall/ceiling and ELS inner facia.



ELS-PB

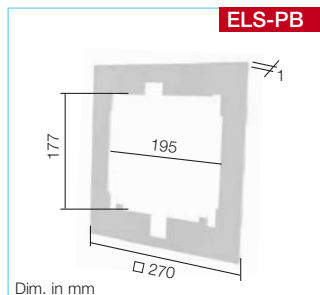

Plasterboard cover

Type ELS-PB Ref. no. 8194

To cover gaps of unclean plastered, tiled or oversized casing openings, which are not completely covered by the ELS facia.

The plasterboard cover is simply fixed between wall/ceiling and ELS inner facia.

Fire protection

The transfer of fire and smoke to other floor levels must be prevented when buildings are higher than two storeys with certified fire protection elements, classification K 90-18017.

The following options and the options described in detail on page 55 can be used here according to structural circumstances.

- Casing ELS-GUB, with fire protection cladding
In fire-resistant shaft (F90) or L90 ventilation duct.
- Casing ELS-GUBA, -GAPB with fire protection shutter for casing positioning outside of fire resistant shaft (F90) or L90 ventilation duct. Connection to main duct with flexible steel duct.

- Fire damper ELS-D
For installation in ventilation main duct Approved for use in ventilation shafts and within mixed service shafts (even with flammable services), only needs to be covered with a 12.5 mm plaster-board. All ELS fans, connected with flexible aluminium ducting do not need any fire protection classifications.

ELS-D Z-41.3-368



Fire damper ELS-D

When using this barrier, all other component parts do not need any fire protection classification. The universal applicable casing types ELS-GU (flush) and GAP (surface) can be connected.

The low cost and assembly-friendly flexible aluminium ducting can be used for the connections. See page 522 for detailed information.

ND mm main duct	100	125	140	160	180	200
Type	ELS-D 100	125	140	160	180	200
Ref. no.	0270	0185	0186	0187	0188	0271

Intake air elements

– Installation in wall openings



Universally applicable supply air units and thermostatic supply valves for the demand-based intake air volume control. See intake air element product page for detailed description.

		ø 80		ø 100		ø 160	
Type	Ref. no.	Type	Ref. no.	Type	Ref. no.	Type	Ref. no.
Supply air unit – Automatically temperature controlled incl. thermostatic supply valve, attenuator and external grille							
ZLA 80	0214	ZLA 100	0215	ZLA 160	0216		
Supply air element – Manually adjustable in four steps incl. valve plate with pull cord, attenuator and external grille							
		ZLE 100	0079				
Thermostatic supply valve – For installation in existing ventilation openings							
ZTV 80	0078	ZTV 100	0073	ZTV 160	0074		

– Installation in window frames



Intake air element with air flow controller and limiter. See intake air element product page for detailed description. Ideally suited for retrofitting and new construction.

V̇					
m³/h	Type	Ref. no.	Type	Ref. no.	
Intake air element for installation in window frames – with air flow controller and limiter					
30	ALEF 30	2100	ALEFS 30	2102	As ALEF, but also sound-insulated
45	ALEF 45	2101	ALEFS 45	2103	
Intake air element for installation in window frames – humidity controlled, with air flow controller and limiter					
7/40	ALEF Hygro 6/45	2056	ALEFS Hygro 6/45	2057	as ALEF Hygro, but also sound-insulated

Overflow



Door grilles

Discreet, screened door transfer grille made from impact resistant polymer, for door installation. See ventilation grille product page for detailed description.

Type LTGW Ref. no. 0246
Made from white polymer.

Type LTGB Ref. no. 0247
Made from brown polymer.

Spare filters



Spare air filter

Filter mats made from regenerable synthetic fibre, class G2.

Type ELF/ELS Ref. no. 8190
Permanent filter for fan units ELS-V, dishwasher-safe, contents = 2 pcs.

Type ELF-ZS Ref. no. 0557
For second room plenum box ELS-ZS, contents = 5 pcs.

Information	Page
Dimensions, detailed technical information as well as further sizes:	
Ventilation grilles	487 on
Intake air elements	512 on
Fire protection elements for use in multi-storey construction with more than 2 full storeys	516 on
Controllers and switches	525 on

The regulations in DIN 18017-3 have been integrated in the diagrams below for simple determination.

60 m³/h Bathrooms or toilets

1 unit per floor

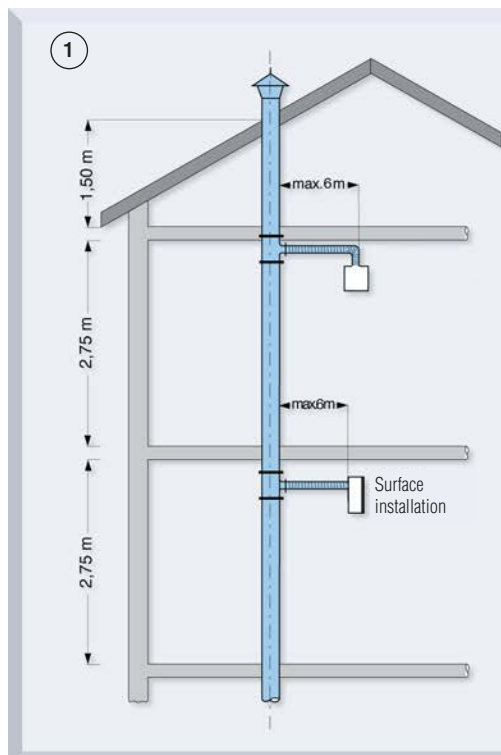

Installation of 1 unit per floor
with 60 m³/h planned air flow volume and
operation of all units at the same time.

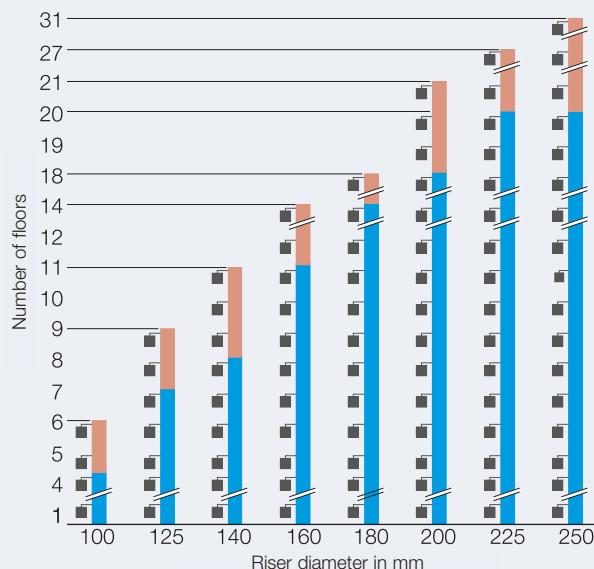

2 units per floor

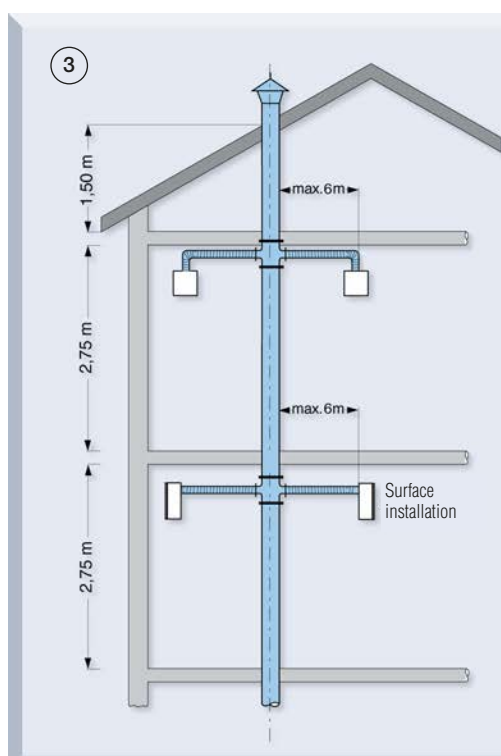

Installation of 2 units per floor
with 60 m³/h planned air flow volume and
operation of all units at the same time.

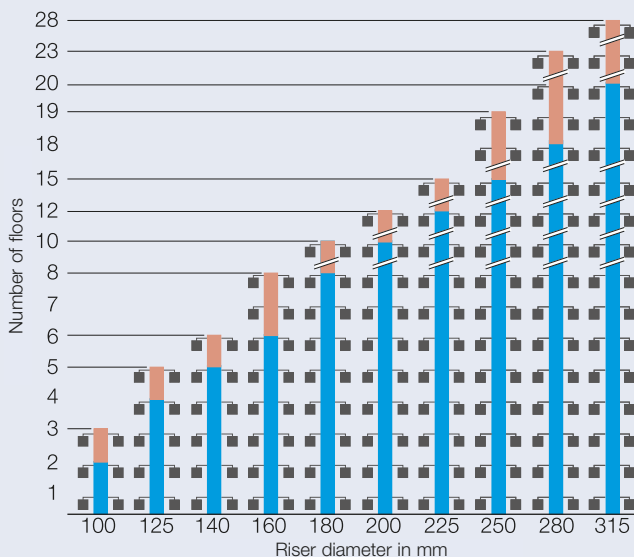

Assuming a room height of 2.75 m, a straight ducting without bends, a ducting length of max. 1.5 m from last unit to air extract above the roof as well as max. 60 Pa between ventilated room and exhaust opening, the required main riser diameter can be read from the diagram above.
They are valid for a planned air flow volume of 60 or 100 m³/h per unit and operation of all units at the same time.

Standard and individual plans can be created easily and quickly with the Helios ELS software. Graphic representation, dimensioning of the main duct with or without warpage become child's play. Cost allocation and materials list are automatically created and printed. Information on the planning and design can be found in DIN 18017-3 and the approval documents and test certificates. We will be happy to send approval documents and test certificates upon request. Approval no. Z-51.1-193.

System dimensioning for these floor heights is not recommended.
Preferred system dimensioning in blue area (comfort zone).

Without reliable supply air backflow through intake air inflow elements ALEF and ZL, the exhaust air systems are not functional and do not comply with engineering rules.

100 m³/h Kitchens and two room ventilation

1 unit per floor (possibly with two room connection)

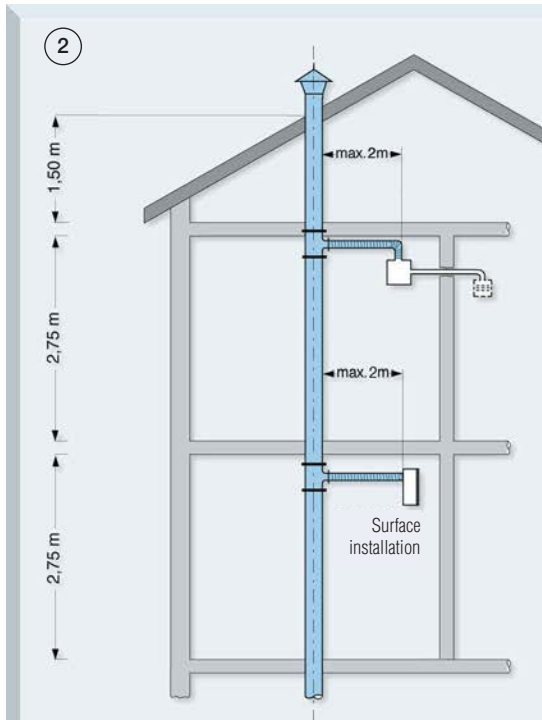

Installation of 1 unit per floor

with 100 m³/h planned air flow volume and operation of all units at the same time. (Volume e.g. kitchen = 100 m³/h. For two room ventilation with 1 unit = Bathroom 60 m³/h, toilet 40 m³/h).

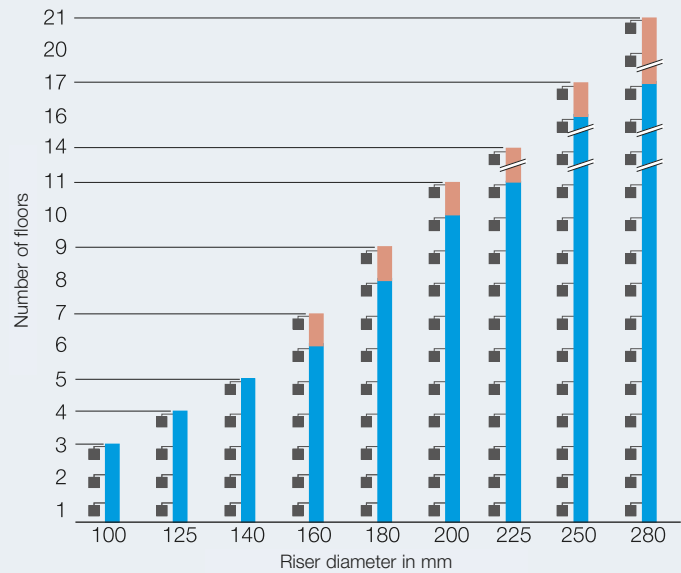

2 units per floor (possibly with two room connection)

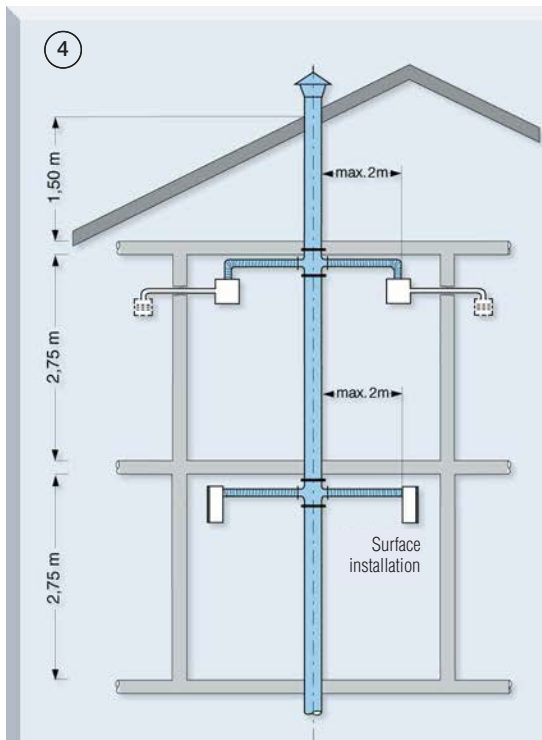

Installation of 2 units per floor

with 100 m³/h planned air flow volume and operation of all units at the same time. (Volume e.g. kitchen = 100 m³/h. For two room ventilation with 1 unit = Bathroom 60 m³/h, toilet 40 m³/h).

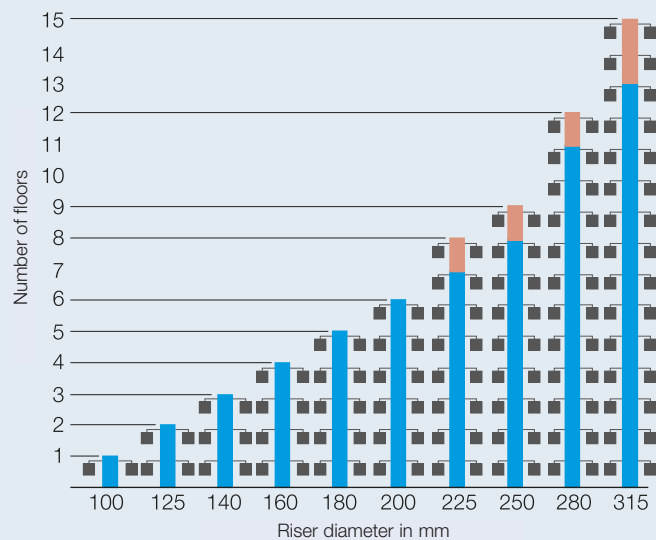

Example 1:

Type of room: Bathroom/Toilet

$\dot{V} = 60 \text{ m}^3/\text{h}$

Units per floor: 1

Floor levels: 9

Main riser diameter: ?

According to diagram ①

Main riser diameter: 125 mm

Example 2:

Type of room: Bathroom and separate toilet with 1 unit
or kitchen ventilation

$\dot{V} = 100 \text{ m}^3/\text{h}$ (Bathroom 60 m³/h and toilet 40 m³/h)

Units per floor: 2

Floor levels: 6

Main riser diameter: ?

According to diagram ④

Main riser diameter: 200 mm

ELS inner facia and flush mounted casing

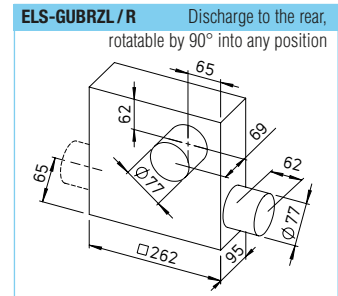
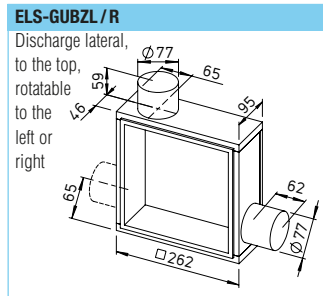
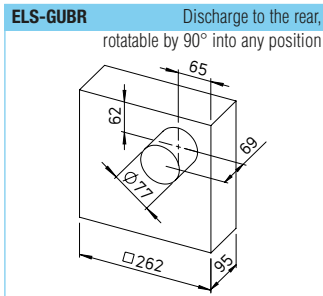
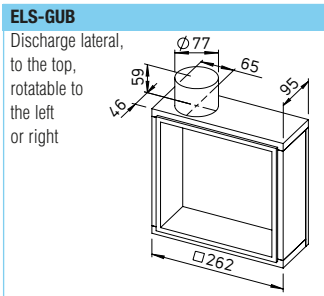
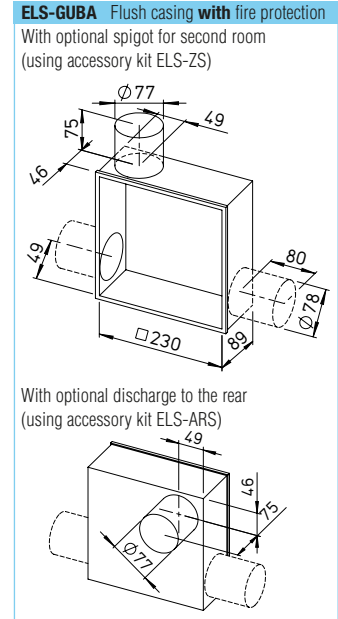
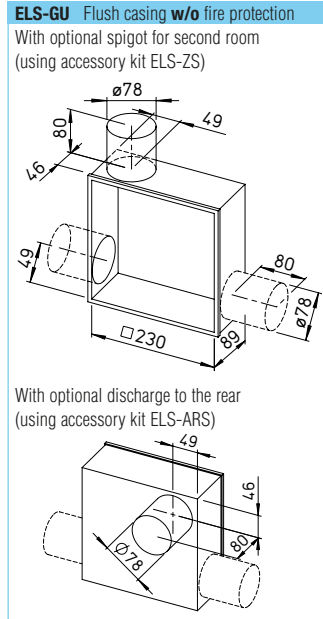
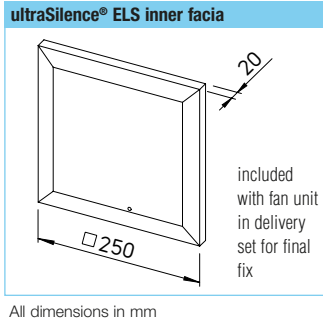

Surface mounted unit and surface mounted casing

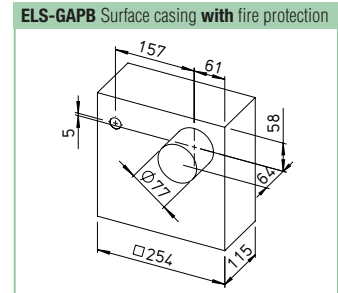
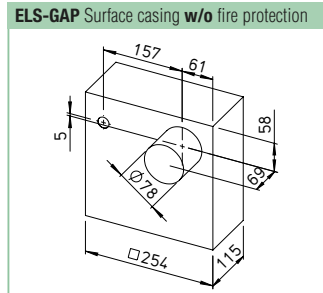
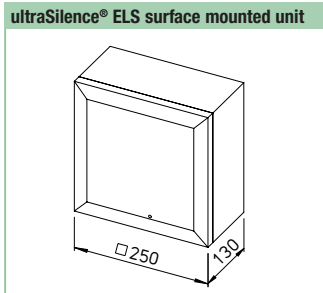

Technical data	Fan unit													
	ELS	-V 60	-VN 60	-VNC 60	-VP 60	-VF 60	-V 60/35	-VN 60/35	-VF 60/35	-V 100	-VN 100	-VNC 100	-VP 100	-VN 100/60
Ref. no.	8131	8137	8143	8149	8161	8133	8139	8163	8132	8138	8144	8150	8141	8136
Run on time, approx. min.	—	6, 15, 21	6, 10, 15, 21	15	6, 10, 15, 21	—	6, 15, 21	6, 10, 15, 21	—	6, 15, 21	6, 10, 15, 21	15	6, 15, 21	—
Interval operation, hrs.	—	—	4, 8, 12, 24	—	—	—	—	—	—	—	4, 8, 12, 24	—	—	—
Air flow volume approx. m³/h	60	60	60	60	60	60/35	60/35	60/35	100	100	100	100	100/60	100/60/35
Power consumption approx. Watt	18	18	18	18	18	18/9	18/9	18/9	29	29	29	29	29/18	29/18/9
Sound pressure level approx. dB(A) at 10 m² equivalent absorption surface	flush ¹⁾	35	35	35	35	35	35/26	35/26	47	47	47	47	47/35	47/35/26
	surface	39	39	39	39	39	39/30	39/30	51	51	51	51	51/39	51/39/30
Sound power level L _{wa} approx. dB(A)	flush ¹⁾	39	39	39	39	39	39/30	39/30	51	51	51	51	51/39	51/39/30
	surface	43	43	43	43	43	43/34	43/34	55	55	55	55	55/43	55/43/34
Electric. connection: 230 V~, 50 Hz	NYM-0	NYM-0	NYM-0	NYM-0	NYM-0	NYM-0	NYM-0	NYM-0	NYM-0	NYM-0	NYM-0	NYM-0	NYM-0	NYM-0
Electrical power supply in mm²	2 x 1,5	3 x 1,5	3 x 1,5	2 x 1,5	3 x 1,5	3 x 1,5	4 x 1,5	4 x 1,5	2 x 1,5	3 x 1,5	3 x 1,5	2 x 1,5	4 x 1,5	4 x 1,5
Protection class II without PE	—	—	4 x 1,5*	—	4 x 1,5*	—	—	5 x 1,5*	—	—	—	—	—	—
Wiring diagram no.	SS-869	SS-875	SS-881	SS-887	SS-881	SS-871	SS-877	SS-883	SS-870	SS-876	SS-882	SS-887	SS-879	SS-874

All power and noise data according to DIN 24163, DIN 24166, DIN 45635, DIN 44974.

¹⁾ in combination with casing type ELS-GU, discharge lateral.

* for deactivation of automatic function.

Central ventilation system ZLS-DV EC according to DIN 18017-3.

Residential ventilation to DIN 18017-3

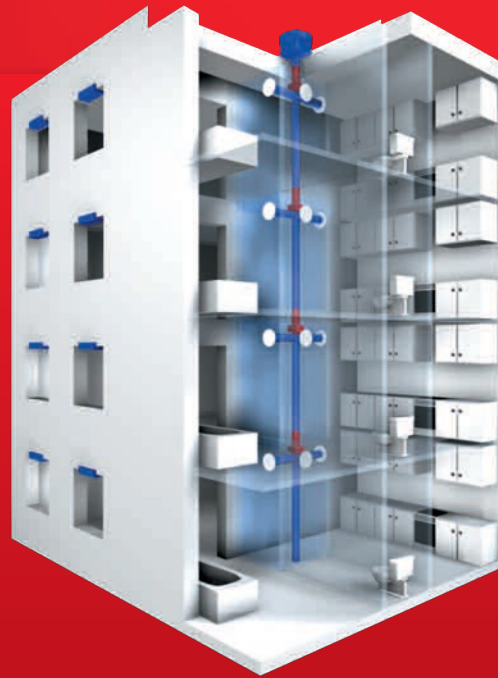

ZLS-DV EC is the ideal central ventilation system in multi-storey construction according to DIN 18017-3.

- Humid, polluted air is extracted in line with requirements. At the same time, the pressure-controlled controller integrated in the fan guarantees that a set negative pressure is maintained. Thus, the planned air flow volume remains unchanged in all other rooms.
- Energy-saving EC technology with highest efficiency, even for controlled operation, and up to 50 % energy saving in comparison with conventional motors.

EXTRACT AIR



The roof fan is connected to the central exhaust shaft. The extract air from wet-rooms and kitchens leaves via extract air elements with demand-oriented function. The automatic, stepless power adjustment takes place via the integrated pressure sensor.

66^{on}

OUTSIDE AIR

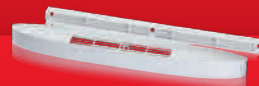

Draught-free outside air is supplied to the living and bedrooms via automatic elements for window or wall installation.

68

FIRE PROTECTION



The spread of fire to other floors is prevented according to building requirements in the classified and unclassified shaft.

69

DV EC

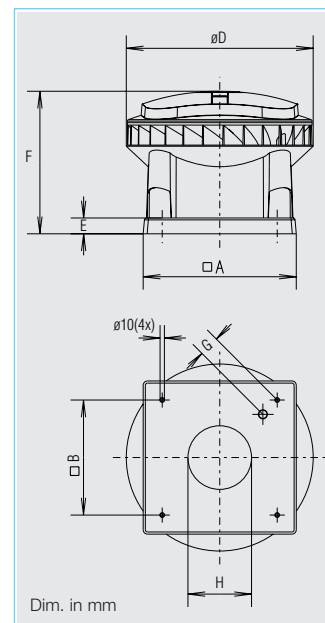

Dim. in mm

up to **45% Saving***
* with speed control

Extremely weather-resistant, polymer EC roof fan for an extensive area of application, diagonal discharge.

Similarities
DV EC Pro and DV EC Eco

Casing
Aerodynamically designed casing from high-quality polypropylene in grey with diagonal air discharge. Air flow temperatures from -30 to +60 °C.

Impeller
Diagonal impeller made from aluminium, the motor-impeller unit is dynamically balanced for low noise operation.

Motor
Energy-efficient EC external rotor motor protected to IP 54. Optimised level of efficiency for speed control for low operating costs. Steplessly speed controllable. Maintenance-free and interference-free, ball bearing mounted.

Motor protection
Integrated electronic temperature monitoring for EC motor and electronics.

Electrical connection
Standard external terminal box (protection class IP 65) on casing. Connection voltage 1 ph., 230 V, 50 Hz.

Installation
Horizontal installation on the roof. In case of pitched roofs, a suitable base must be provided to prevent water entry. Extensive accessories facilitate the assembly of the fan to the ducting system in the building.

Sound levels
Total sound power levels and the spectrum figures in dB(A) are given for:
- Sound power intake
- Sound power exhaust
You can also find sound pressure levels at 4 m (free field conditions) in the table below and below the performance curve.

Specification DV EC Pro

- Speed control**
 - Ideal as central exhaust air fan for multi-storey building according to DIN 18017-3.
 - In connection with other components (accessories), a complete central ventilation system can be developed according to DIN 18017-3 with demand-driven ventilation.
 - Integrated pressure control for air flow volume stabilisation in the connected rooms by automatic speed adaptation with almost constantly good level of efficiency.
 - Integrated pressure sensor 0-300 Pa.
 - Short pay back time due to high energy conservation.
 - Four potentiometers integrated in the control permit an adjustment to the operating data. The desired operating point can be set directly on site.
 - Integrate serial Bus port (RS 485) for connection of a PC/laptop in combination with the interface (accessories).

Dimensions in mm

Type	DV EC 200	DV EC 250	DV EC 400
□ A	460	580	665
□ B	330	450	535
∅ D	575	708	863
E	60	60	60
F	473	540	601
G	44	48	64
H	196	241	302

Specification DV EC Eco

- Speed control**
 - Stepless speed control with a speed-potentiometer PU/PA 10 (accessories, see table below).
 - In connection with the universal control system EUR EC or electronic pressure/temperature controllers EDR/ETR (accessories, see table below), the fan can be used for stepless differential pressure, differential temperature or flow velocity regulation. For example, the performance levels are shown in the performance curves.

Type	Ref. no.	Maximum R.P.M. approx.	Air flow volume (FID)	Sound pressure case breakout	Power consumption at maximum R.P.M.		Wiring diagram	max. air flow temperature	Weight net approx.	Timer / Universal control system		Speed-potentiometer surface flush			
					kW	A				No.	+ °C	kg	Type	Ref. no.	Type
Type DV EC Pro, 1 ph. motor, 230 V, 50/60 Hz, EC motor, IP 54											Timer				
DV EC 200 Pro	8385	1810	2010	52	0.18	1.38	863.1	60	17.0	ZLS-ZU 31	8388	—	—	—	—
DV EC 250 Pro	8386	1640	3700	60	0.41	1.78	863.1	60	23.0	ZLS-ZU 31	8388	—	—	—	—
DV EC 400 A Pro	8387	1020	4070	51	0.30	1.33	863.1	60	33.0	ZLS-ZU 31	8388	—	—	—	—
DV EC 400 B Pro	8389	1425	5650	65	0.75	3.32	863.1	60	35.0	ZLS-ZU 31	8388	—	—	—	—
Type DV EC Eco, 1 ph. motor, 230 V, 50/60 Hz, EC motor, IP 54											Control system				
DV EC 200 Eco	8320	1810	2010	52	0.18	1.38	991	60	17.0	EUR EC ⁽¹⁾²⁾	1347	PU 10 ³⁾	1734	PA 10 ³⁾	1735
DV EC 250 Eco	8322	1640	3700	60	0.41	1.78	991	60	23.0	EUR EC ⁽¹⁾²⁾	1347	PU 10 ³⁾	1734	PA 10 ³⁾	1735
DV EC 400 A Eco	8324	1020	4070	51	0.30	1.33	991	60	33.0	EUR EC ⁽¹⁾²⁾	1347	PU 10 ³⁾	1734	PA 10 ³⁾	1735
DV EC 400 B Eco	8326	1425	5650	65	0.75	3.32	991	60	35.0	EUR EC ⁽¹⁾²⁾	1347	PU 10 ³⁾	1734	PA 10 ³⁾	1735

¹⁾ Several EC fans can normally be connected

²⁾ alternative electronic pressure/temp. controller (EDR/ETR, No. 1437/1438) in connection with power supply NG24, No. 1439, see Accessories

³⁾ without LED power supply

DV EC 200

Frequency		Hz	Total	125	250	500	1k	2k	4k	8k
L _{WA}	Intake	dB(A)	70	54	64	64	65	61	55	46
L _{WA}	Exhaust	dB(A)	72	53	57	66	69	66	57	46

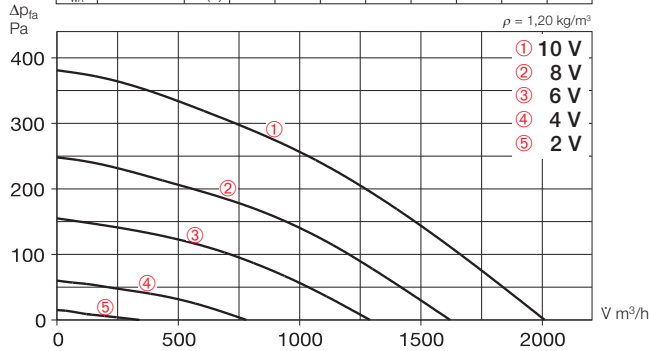

Voltage V	n min ⁻¹	\dot{V} m ³ /h	P W	I A	L _p dB(A)	SFP kW/m ³ /s
10	1810	2010	180	1.38	52	—
8	1480	1620	108	0.90	47	—
6	1200	1290	60	0.54	41	—
4	720	780	21	0.20	31	—

DV EC 250

Frequency		Hz	Total	125	250	500	1k	2k	4k	8k
L _{WA}	Intake	dB(A)	75	60	64	70	69	67	61	52
L _{WA}	Exhaust	dB(A)	80	63	65	75	76	72	63	52

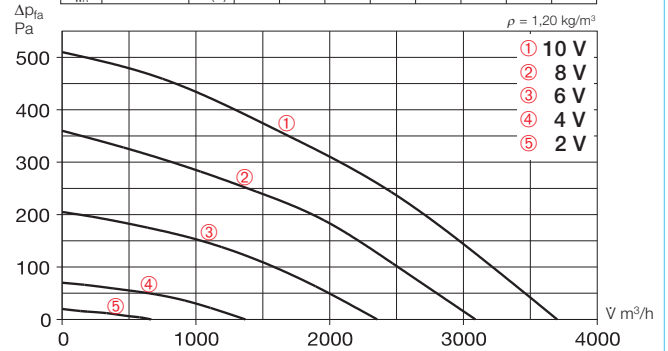

Voltage V	n min ⁻¹	\dot{V} m ³ /h	P W	I A	L _p dB(A)	SFP kW/m ³ /s
10	1640	3700	412	1.78	60	—
8	1380	3100	264	1.14	55	—
6	1100	2350	138	0.60	49	—
4	650	1370	40	0.20	36	—

DV EC 400 A

Frequency		Hz	Total	125	250	500	1k	2k	4k	8k
L _{WA}	Intake	dB(A)	68	55	62	63	63	58	51	44
L _{WA}	Exhaust	dB(A)	72	56	61	68	67	60	52	43

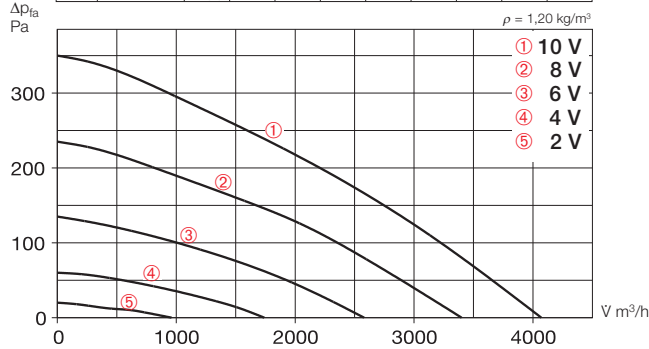

Voltage V	n min ⁻¹	\dot{V} m ³ /h	P W	I A	L _p dB(A)	SFP kW/m ³ /s
10	1020	4070	303	1.33	51	—
8	850	3400	176	0.77	46	—
6	650	2580	85	0.40	40	—
4	450	1740	33	0.20	31	—

DV EC 400 B

Frequency		Hz	Total	125	250	500	1k	2k	4k	8k
L _{WA}	Intake	dB(A)	80	64	69	75	74	74	65	58
L _{WA}	Exhaust	dB(A)	85	66	72	82	81	76	66	56

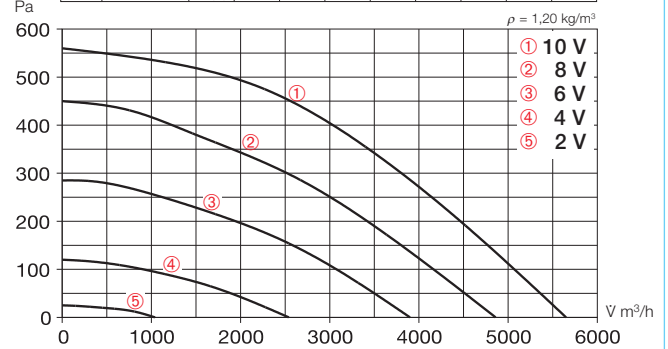

Voltage V	n min ⁻¹	\dot{V} m ³ /h	P W	I A	L _p dB(A)	SFP kW/m ³ /s
10	1425	5650	755	3.32	65	—
8	1225	4860	485	2.10	60	—
6	1000	3900	265	1.15	54	—
4	650	2540	90	0.40	43	—

Extract air



AE
Ready-to-install extract air element with polymer mounting ring.
To be inserted into ducting with diam. 125 mm. With demand-based and standard ventilation stages, electrical, humidity, motion and time controlled for use pursuant to the following table.
Types AE and AE GB with self-regulating air flow volume stabilisation. Humidity controlled types AE Hygro or type AE FV with filter and air flow volume control are preferable for kitchens and bathrooms.
Adapter filter element VFE
For installation in front of AE, if room air is polluted and greasy. See product page for details.

– Fire protection shutters for extract air elements AE



– Cold smoke shutter KAK



– Noise reduction element SVE (also suitable for supply air)



Overflow



Intake air elements

– Installation in wall openings



ZL
Universal supply air unit and thermostatic valve for controlled air intake regulation. See intake air element product pages for detailed descriptions.

– Installation in window frames



ALEF
Intake air element with air flow volume control and limiter. See intake air element product pages for detailed descriptions. Ideally suitable for retrofitting and new construction.

Bathroom		Toilet		Kitchen	
Type	Ref. no.	Type	Ref. no.	Type	Ref. no.
Extract air element with self-regulating air flow volume stabilisation * Air flow volume in m³/h					
AE 45*	2031	AE 30*	2030	AE 75*	2033
As above , but with two air flow volumes (demand-based and standard ventilation)					
AE GB 20/75*	2036	AE GB 15/30*	2035	AE GB 45/120*	2038
As AE GB , with additional electr. timer (without air flow volume stabilisation)					
AE GBE 30/60*	2047	AE GBE 15/30*	2044	AE GBE 45/120*	2048
As AE GBE , but with motion sensor					
		AE B 15/30*	2055		
Humidity controlled extract air unit with variable, limited air flow volume					
AE Hygro 10/45*	2049				
As AE Hygro , with additional electrically controlled demand-based ventilation stage					
AE Hygro GBE 5/40/75*	2053			AE Hygro GBE 10/45/120*	2054
Extract air element AE FV , with filter and air volume control					
AE FV 125	9478			AE FV 125	9478
Adapter filter element VFE					
– to AE / AE GBE, AE Hygro, prevents contamination of the air extract element and ducting system					
				VFE 70/VFE 90	2552/2553

Fire and smoke shutter.

Suitable for insertion into spiral ducting without additional mounting frame or wall installation with mounting sleeve EH (accessories).

Cold smoke shutter with magnetic closure. Prevents backflow of cold smoke into other fire areas in central ventilation system.

* ND 125, suitable for AE above. See product pages for other ND and detailed descriptions.

Type	Ref. no.
Fire protection shutter K 90-18017	
BAE 125*	2626
Fire protection shutter K 90-4102	
BAK 125*	2621
Mounting sleeve (accessories for both types)	
EH 125*	2640
Cold smoke shutter	
KAK 125*	4098

Noise reduction elements for simple noise-absorption and air volume regulation in central ventilation systems through duct insertion. Also suitable for pressure regulation.

Door grilles

Discreet, screened ventilation grille made from impact-resistant polymer for door installation.

Type SVE 100	Ref. no. 8310
ND 100 mm	
Type SVE 125*	Ref. no. 8311
ND 125 mm	
Type LTGW	Ref. no. 0246
Made from white polymer.	
Type LTGB	Ref. no. 0247
Made from brown polymer	

	Ø 80		Ø 100		Ø 160	
Type	Ref. no.	Type	Ref. no.	Type	Ref. no.	
Supply air unit – Automatic temperature control incl. thermostatic valve, acoustic lining and external grille						
	ZLA 80	0214	ZLA 100	0215	ZLA 160	0216
Supply air element – Manual control in four stages incl. valve plate with pull cord, sound insulation and external grille						
			ZLE 100	0079		
Thermostatic valve – For installation in existing ventilation openings						
	ZTV 80	0078	ZTV 100	0073	ZTV 160	0074

V					
m³/h	Type	Ref. no.	Type	Ref. no.	Type
Intake air inlet element for installation in window frames – with air volume control and limiter					
30	ALEF 30	2100		ALEFS 30	2102
45	ALEF 45	2101		ALEFS 45	2103
Intake air inlet element for installation in window frames – humidity control, with air volume control and limiter					
6/45	ALEF Hygro 6/45	2056		ALEFS Hygro 6/45	2057

Flange connecting plate

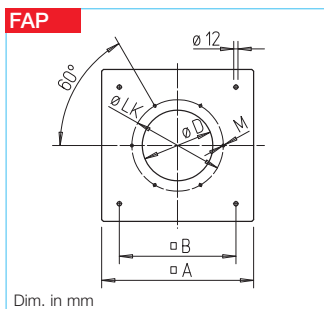

Flange connecting plate FAP
Made from galvanised sheet steel. Allows the connection of the duct system and accessories to the roof fans DV EC, if no base attenuator SSD is used.

Type	FAP 200	FAP 250	FAP 400
Ref. no.	8382	8383	8384
□ A mm	430	550	635
□ B mm	330	450	535
∅ D mm	200	250	400
∅ LK mm	259	286	438
M	M 6	M 6	M 8
Weight kg	1.8	3.0	3.3

Flange, flanged flexible connector



Suitable for roof fan:					
DV EC 200		DV EC 250		DV EC 400	
Type	Ref. no.	Type	Ref. no.	Type	Ref. no.
Flange connecting plate – necessary for duct connection					
FAP 200	8382	FAP 250	8383	FAP 400	8384
Counterflange					
DFR 200	1201	FR 250	1203	FR 400	1206
Flanged flexible connector					
DSTS 200	1218	STS 250	1220	STS 400	1223

See product pages for detailed descriptions.

Flat roof base



Base attenuator

Suitable for roof fan:					
DV EC 200		DV EC 250		DV EC 400	
Type	Ref. no.	Type	Ref. no.	Type	Ref. no.
Flat roof base – with hinge mechanism for easy maintenance					
FDS 200	1378	FDS 250	1379	FDS 400	1380
Base attenuator – with hinge mechanism for easy maintenance					
SSD 200	5290	SSD 250	5292	SSD 400	5291

See product pages for detailed descriptions.

Fire protection



Fire damper ELS-D prevents spread of fire to other floors.
Installation in ventilation main duct to DIN 18017 K90. Maintenance free. Approved for use in ventilation shafts or mixed service shafts (even with flammable ducts) only needs to be covered with 12.5 mm plaster-

board cover. All other parts (valves etc.) do not need fire protection classification. Flexible aluminium ducting can be used for the connections. Shutters KAK are to be provided to avoid backflow of cold smoke (see left page).

ND mm main duct	100	125	140	160	180	200
Type	ELS-D 100	125	140	160	180	200
Ref. no.	0270	0185	0186	0187	0188	0271

Control



Interface
Interface for the start-up and/or control of the fan in connection with a PC/Laptop. Power supply unit, adaptor cable and software included.

Type ZLS-IF Ref. no. 8391

Electronic timer module with day/night regulator
Allows parallel operation of max. 31 DV EC roof fans. The rocker main switch activates the timer module. The day and night regulation is carried out via the settings on the display.
Incl. main switch. 230 V, 50 Hz.
Type ZLS-ZU 31 Ref. no. 8388

Accessory details	Page
Roof installation accessories	485
Ventilation grilles	487 on
Extract air elements	500 on
Intake air elements	512 on
Fire protection systems	
– Fire damper	516 on
Universal control systems, electronic controllers, speed-potentiometer	539 on



Universal control system
For stepless control or regulation of single or three phase EC fans with a setpoint of 0-10 V DC:
Type EUR EC Ref. no. 1347

Speed-potentiometer
For direct control/setpoint setting of EC fans with potentiometer inputs.
Type PU 10 (up) Ref. no. 1734



Type PA 10 (ap) Ref. no. 1735