

CARATTERISTICHE TECNICHE  
TECHNICAL SPECIFICATIONS

TYPE "HMS"

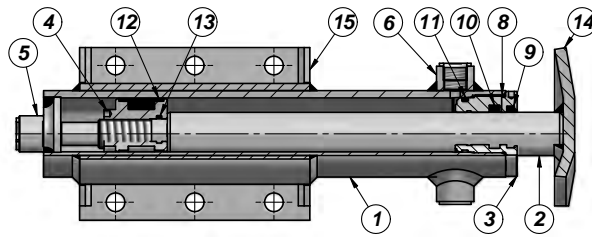

Pressione Massima - Max. Pressure: 250 Bar (\*\*)

PRODOTTO - PRODUCT	MATERIALE - MATERIAL
1 TUBO LUCIDO POLISHED TUBE	ACCIAIO: St 52.3 DIN 2393 ISO H9 STEEL: St 52.3 DIN 2393 ISO H9
2 STELO CROMATO CHROMED ROD	ACCIAIO: UNI C45 - SAE 1045 - CROMO 25 Micron ±5 Rating 9 / 120 h ISO 10289 - 1999/ISO 9227-NSS STEEL: UNI C45 - SAE 1045 - CHROME 25 Micron ±5 Rating 9 / 120 h ISO 10289 - 1999/ISO 9227-NSS
3 TESTATA DI GUIDA HEAD BUSH	GHISA: EN-GJL 250 ( G25-UNI 5007 / EN 1561 ) HYDRAULIC CAST IRON: EN-GJL 250 ( G25-UNI 5007 / EN 1561 )
4 PISTONE PISTON	ACCIAIO: 9SMn28 - C40 STEEL: 9SMn28 - C40
5 FONDELLO END PLUG	ACCIAIO: S355J0 (Fe510C) - S355JR (A105) STEEL: S355J0 (Fe510C) - S355JR (A105)
6 BORCHIA FILETTATA THREADED PORT	ACCIAIO STEEL
8 GUARNIZIONE: O-RING SEAL: O-RING	NBR 70 SHORE NBR 70 SHORE
9 GUARNIZIONE: GHK SEAL: GHK	POLIURETANO POLYURETHANE
10 GUARNIZIONE: TSE-TTS-TT/VL SEAL: TSE-TTS-TT/VL	TSE : NBR+TESSUTO TSE : NBR+FABRIC
11 GUARNIZIONE: O-RING SEAL: O-RING	NBR 70 SHORE NBR 70 SHORE
12 GUARNIZIONE: TPM SEAL: TPM	NBR+POM+TPE NBR+POM+TPE
13 GUARNIZIONE: O-RING SEAL: O-RING	NBR 70 SHORE NBR 70 SHORE
14 FLANGIA FLANGE	ACCIAIO: S355J0 (Fe510C) STEEL: S355J0 (Fe510C)
15 PIASTRA PLATE	ACCIAIO: S355J0 (Fe510C) STEEL: S355J0 (Fe510C)

Velocità Limite - Top Speed: max 0,5 m/s      Temperatura C° - Temperature C°: -25°C - +80°C

(\*\*) Il dato della pressione è sempre da verificare in base all'applicazione del cilindro.

(\*\*) The pressure value is always to be checked depending on the application of the cylinders.

CARATTERISTICHE TECNICHE  
TECHNICAL SPECIFICATIONS

FORZA IN SPINTA - OUTPUT FORCE

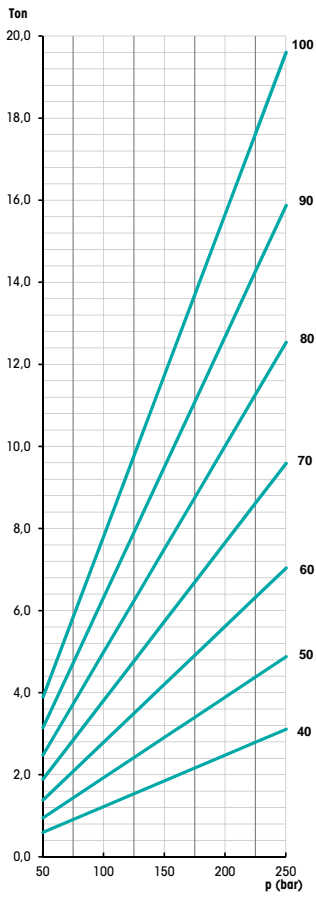

FORZA IN TIRO - INPUT FORCE

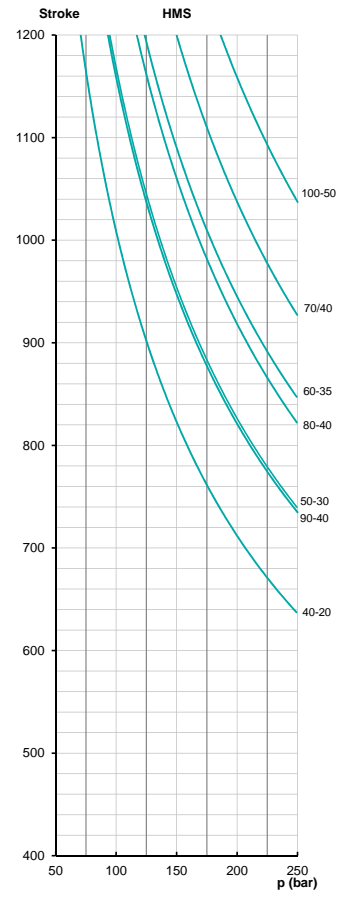
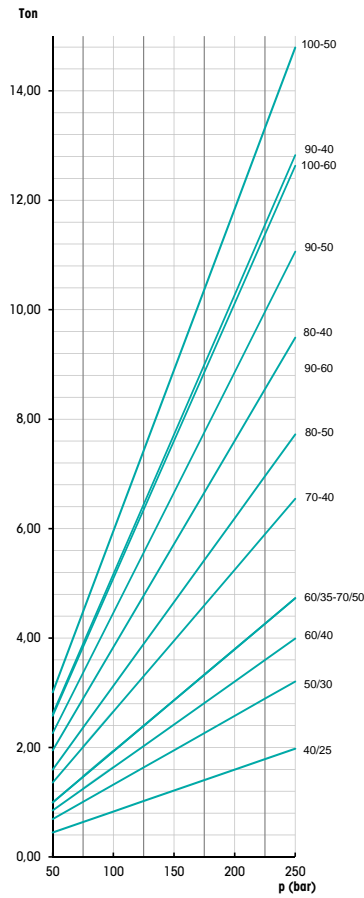

CILINDRO STABILIZZATORE  
HYDRAULIC STABILIZER CYLINDER

NEW!

HMS

Series M250

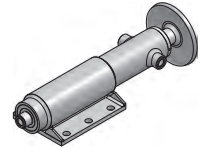
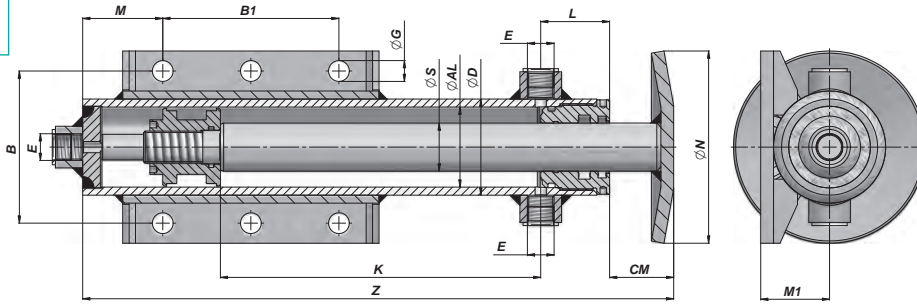

Codice Code	K	Z	kg	E BSP	L	CM	ØN	M1	B	M	B1	ØG	Codice Code	K	Z	kg
<b>ØD 50 ØAL 40 ØS 25</b>																
HMS00400250200	200	369	6,36	3/8"	40	40	110	38	85	50	100	13				
HMS00400250300	300	469	7,30													
HMS00400250400	400	569	8,23													
HMS00400250500	500	669	9,17													
HMS00400250600	600	769	10,11													
<b>ØD 60 ØAL 50 ØS 30</b>																
HMS00500300200	200	369	8,19	3/8"	43	40	120	43	95	50	110	13				
HMS00500300300	300	469	9,42													
HMS00500300400	400	569	10,65													
HMS00500300500	500	669	11,87													
HMS00500300600	600	769	13,11													
<b>ØD 70 ØAL 60 ØS 35</b>													<b>ØD 70 ØAL 60 ØS 40</b>			
HMS00600350200	200	371	11,10	3/8"	50	40	130	50	105	53	125	13	HMS00600400200	200	371	11,65
HMS00600350300	300	471	12,65										HMS00600400300	300	471	13,43
HMS00600350400	400	571	14,20										HMS00600400400	400	571	15,21
HMS00600350500	500	671	15,75										HMS00600400500	500	671	16,99
HMS00600350600	600	771	17,30										HMS00600400600	600	771	18,77
<b>ØD 80 ØAL 70 ØS 40</b>													<b>ØD 80 ØAL 70 ØS 50</b>			
HMS00700400200	200	410	14,16	1/2"	50	50	150	55	120	53	125	15	HMS00700500200	200	410	14,70
HMS00700400300	300	510	15,83										HMS00700500300	300	510	16,60
HMS00700400400	400	610	17,51										HMS00700500400	400	610	18,51
HMS00700400500	500	710	19,18										HMS00700500500	500	710	19,49
HMS00700400600	600	810	20,85										HMS00700500600	600	810	22,31
<b>ØD 90 ØAL 80 ØS 40</b>													<b>ØD 90 ØAL 80 ØS 50</b>			
HMS00800400200	200	410	17,69	1/2"	60	50	160	62	125	58	145	15	HMS00800500200	200	410	19,04
HMS00800400300	300	510	19,72										HMS00800500300	300	510	21,62
HMS00800400400	400	610	21,74										HMS00800500400	400	610	24,20
HMS00800400500	500	710	23,77										HMS00800500500	500	710	26,78
HMS00800400600	600	810	25,80										HMS00800500600	600	810	29,36
<b>ØD 100 ØAL 90 ØS 40</b>													<b>ØD 100 ØAL 90 ØS 50</b>			
HMS00900400200	200	410	20,30	1/2"	60	50	170	67	135	60	150	15	HMS00900500200	200	410	21,65
HMS00900400300	300	510	22,45										HMS00900500300	300	510	24,35
HMS00900400400	400	610	24,59										HMS00900500400	400	610	27,05
HMS00900400500	500	710	26,74										HMS00900500500	500	710	29,76
HMS00900400600	600	810	28,89										HMS00900500600	600	810	32,46
<b>ØD 110 ØAL 100 ØS 50</b>													<b>ØD 110 ØAL 100 ØS 60</b>			
HMS01000500200	200	420	26,92	1/2"	82	60	180	73	145	60	170	15	HMS01000600200	200	420	28,61
HMS01000500300	300	520	29,74										HMS01000600300	300	520	32,11
HMS01000500400	400	620	32,57										HMS01000600400	400	620	35,61
HMS01000500500	500	720	35,39										HMS01000600500	500	720	39,11
HMS01000500600	600	820	38,22										HMS01000600600	600	820	42,61

MATERIALE TUBO: ACCIAIO St 52.3 DIN 2393 ISO H9  
TUBE MATERIAL : STEEL St 52.3 DIN 2393 ISO H9

MATERIALE ASTA: ACCIAIO UNI C45 SAE 1045 CROMO 25 MICRON ±5 Rating 9 / 120 h ISO 10289 - 1999/ISO 9227-NSS  
ROD MATERIAL : STEEL UNI C45 SAE 1045 CHROME 25 MICRON ±5 Rating 9 / 120 h ISO 10289 - 1999/ISO 9227-NSS

ALTRE MISURE A RICHIESTA - OTHER DIMENSIONS ON REQUEST

CARATTERISTICHE TECNICHE : VEDI PAGINA 34 - TECHNICAL SPECIFICATIONS : SEE PAGE 34