

## ROTARY (Carousel) PARKING SYSTEM SYSTEM (PTT20/1700)

- Carousel parking system is the best mechanical independent parking at streets.
- The most space-efficient parking system as you can park up to 16 cars in a space 5.5 m width x 6.5 m length.
- Different models with 8, 10, 12, 14 & 16 car spaces for either Sedan and SUV cars according to permissible site height.
- German SEW geared motor drive with roller chain & sprocket mechanism.
- Designed to park vehicles by vertically circulating cage in CW / CCW directions.
- All cages are moving simultaneously through heavy duty conveyor sprocket shaft.
- Simple operation through push button controls / IC cards.
- Electric panel is equipped with PLC, Schneider type.
- Steel parts are shot blasted then powder coated with desired color.

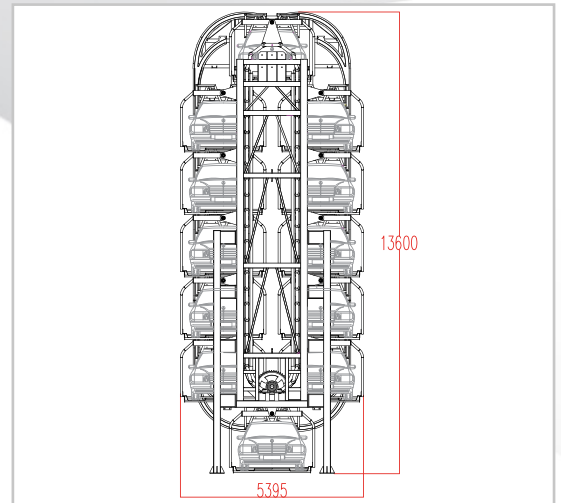

PARAMETERS		ROTARY PARKING SYSTEM (PCX)	
Model	PCX12D	PCX12DH	
Lifting Capacity	1800 Kg	2300 Kg	
Vehicle Size	5300 x 1850 x 1550 mm	5300 x 2100 x 2000 mm	
Installation Space	6500 x 5500 x 13600 mm	6500 x 5700 x 16700 mm	
Unit Weight	25 Tons	35 Tons	
Shipping Load	2x40HQ	2x40HQ	
Operation System	Front fixed Gearmotor with chains. PLC control + IC card		
Motor Power	9.2 Kw SEW- Germany	15 Kw SEW- Germany	
Voltage	380 V / 50 Hz-60 Hz / 3Ph		

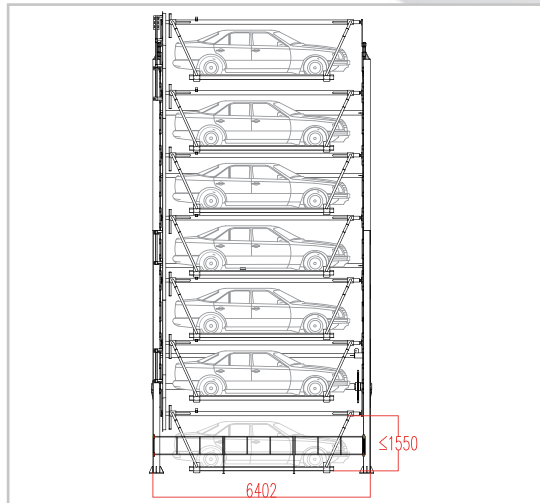