

Marggo

MINI · MEGA · MIX

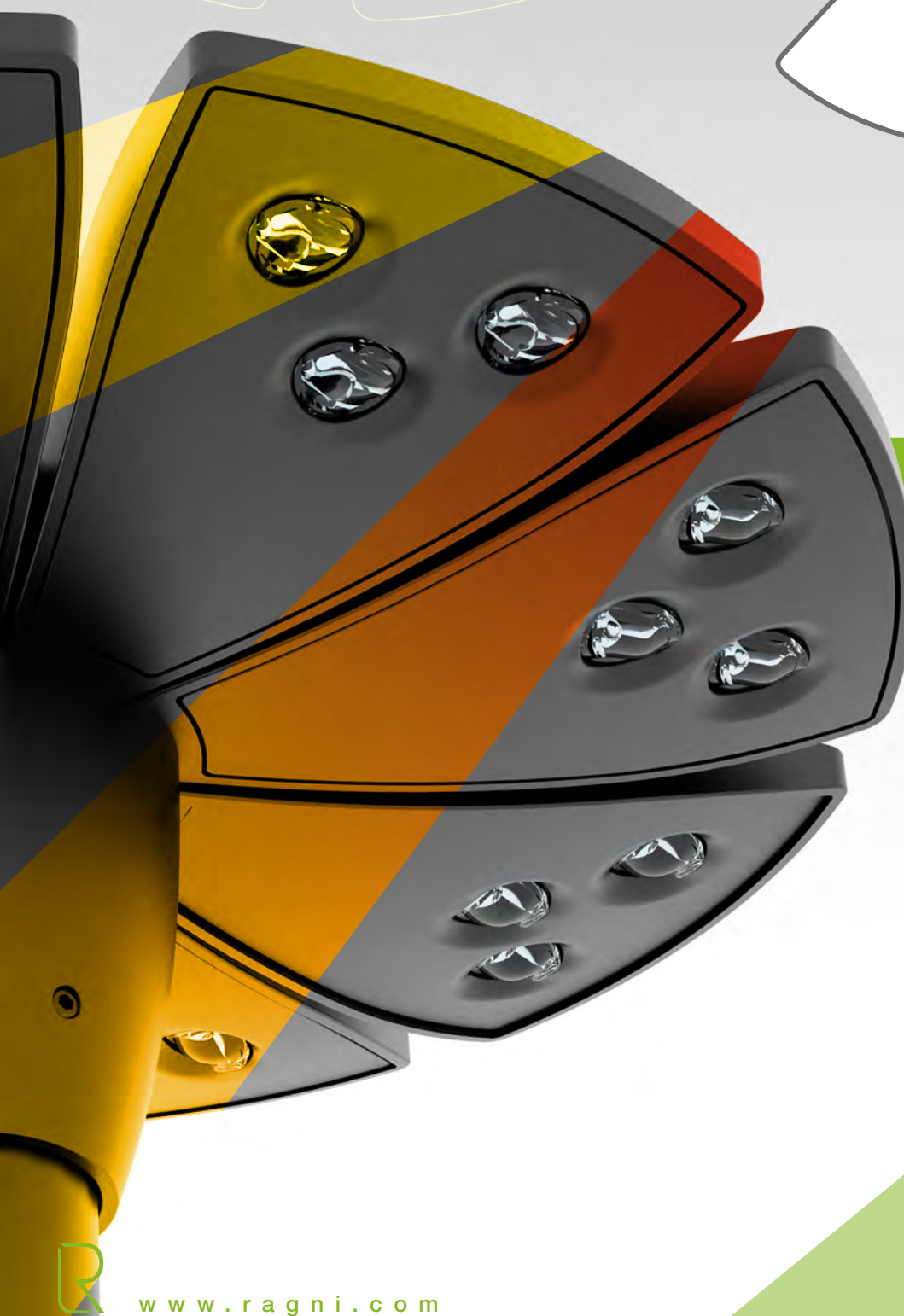

**ECO-DESIGN
ET MODULARITÉ**
ECO-DESIGN AND MODULARITY



www.ragni.com



Margo

MINI - MEGA - MIX



Gamme éclairage ambiance - Résidentiel
Ambiance lighting product range - Residential



Eclairage moderne pour luminaire nature. Margo conjugue la modernité de son design avec la maîtrise de la technologie LED. Inspiré de la beauté naturelle des fleurs, le design de Margo est unique, affirmé et devrait ravir les partisans de l'éco-design.

Personnalisation dans l'air du temps. Après les portables, les vêtements et les voitures personnalisables dans les moindres détails, Margo est probablement l'un des luminaires du marché qu'on peut le plus personnaliser. Grâce à sa grande modularité on peut choisir le nombre et la disposition des pétales, leurs tailles, leurs couleurs et leur puissance d'éclairage.

Une référence en termes de performances. Mais le Margo ne se contente pas d'être esthétique, il est avant tout à la pointe en termes de performance d'éclairage et d'efficacité énergétique. Les équipes de Ragni ont su tirer le meilleur de la technologie LED pour en faire un luminaire de référence.

La technologie LED. Des pétales fins, une faible pollution lumineuse, et un choix multiple de configurations d'éclairage, c'est grâce à la LED que Margo est si original et performant.

Modern lighting inspired by nature. Margo blends modern design with mastery of LED technology. Influenced by the natural beauty of flowers, the Margo's design is unique, assertive, and should delight fans of eco-design.

Trendy customisation. In the wake of cell phones, clothing and cars that can be personalized down to the very last detail, Margo is probably one of the luminaires which can be most extensively personalized on today's market.

Thanks to its high level of modularity, you can choose the quantity and arrangement of the petals, their sizes, colors and lighting intensity.

A reference in terms of performance. The Margo is not just visually appealing: it is, first of all, a spearhead model in terms of performance for both lighting and energy efficiency. The Ragni teams have succeeded in applying the best of LED technology to make it a real reference in the world of lighting.

LED technology. Fine petals, low light pollution and a wide choice of lighting configurations; it is thanks to LED technology that Margo is so original and offers such high performance.



Mise à jour 01/08/16

Update

Toutes les informations sont susceptibles de modification sans préavis.
All informations are subject to change without notice.

www.ragni.com





Margo
MINI - MEGA - MIX

Points forts Highlights



Caractéristiques techniques

- Luminaire entièrement en fonderie d'aluminium injecté.
- Très faible prise au vent grâce à la finesse de Margo.
- Grande modularité : possibilité de choisir sa configuration.
- Fixation en top de mât, suspendue, contre poteau ou murale.



Performances d'éclairage

- LED parmi les meilleures du marché.
 - Éclairage apaisant instaurant un sentiment de sécurité.
 - Puissance d'éclairage adaptée suivant les besoins.
 - Très faible pollution lumineuse : **ULOR* 1,6%**.
- *ULOR : pourcentage du flux lumineux directement dirigé vers le haut.
- **Durée de vie des LED : 80 000 heures à 70% @700 mA.**
 - Efficacité optimale des LED grâce à une bonne gestion thermique.
 - La forme des lentilles permet de limiter l'éblouissement.



Installation & maintenance

- Installation rapide grâce à un emmanchement facile.
- Un seul branchement à faire pour l'installation malgré la multiplicité des LED.
- La maintenance pour les versions sur mât s'effectue via une porte en pied de poteau.
- L'appareillage est placé dans un caisson spécial au-dessus du luminaire en version murale.
- En remplacement, pas de modifications des raccordements électriques ni d'accessoires de fixation supplémentaires.



Esthétique

- Design Ragni exclusif.
- Design affirmé, moderne et inspiré de la nature.
- Très personnalisable pour s'adapter à tout type d'ambiance.
- Grand choix de déclinaisons : deux tailles et mix des deux, et un très grand choix de combinaisons de couleurs.
- Quand le nombre de LED nécessaire est atteint, possibilité de mettre des pétales factices (sans LED) pour garder l'esthétique de la fleur.



Responsabilité environnementale et sociétale

- **Faibles émissions de CO₂.** Grâce au choix des matériaux, du système optique performant et du nombre réduit d'emballages.
- **L'éclairage asymétrique - éclairage 180° - ne produit pas de flux vers l'arrière donc pas de nuisance pour les riverains.**
- Luminaire éligible au certificat d'économie d'énergie.

Technical characteristics

- Luminaire entirely made of injected cast aluminium.
- Very high wind resistance thanks to the finesse of its design.
- High level of modularity: configuration as per the client's choice.
- Top mounted, suspended, against a pole or wall-mounted

Lighting performance

- LEDs from among the best on the market.
 - Calming lighting giving a feeling of safety.
 - Lighting adapted to meet specific requirements.
 - **Very low light pollution: ULOR* 1.6%.**
- *ULOR: upward light output ratio.
- **LED life cycle: 80,000 hours at 70% @700 mA.**
 - **Maximum LED efficiency thanks to good heat management.**
 - Limited dazzle thanks to the shape of the lenses.

Installation & maintenance

- Rapid installation with easy fitting.
- Single connection needed for the installation despite the multiple LEDs.
- For the wall-mounted version, the control gear is housed in a dedicated case above the luminaire.
- For the other versions, the driver is reachable through a door at the bottom of the pole.
- When installed as a replacement solution, no modifications of the electrical connections to be made nor any additional fixation accessories to be used.

Appearance

- Exclusive Ragni design.
- Assertive, modern design inspired by nature.
- Highly personalisable to adapt to all kinds of ambiances.
- Wide range: two sizes and a combination of the two, multiple choice of color combinations.
- When the required number of LEDs is reached, possibility of adding fake petals (without LEDs) to preserve the flower's esthetic appeal.

Environmental and social responsibility

- **Low CO₂ emissions.** Thanks to the choice of the materials, the high performance optical system and a reduced amount of packaging.
- **180° asymmetric lighting does not produce any light to the rear, thus avoiding nuisance for roadside properties.**
- Luminaire eligible for the energy savings certificate.





Margo

MINI - MEGA - MIX



Caractéristiques techniques

Technical characteristics

Déclinaisons

Le Margo se décline dans une multitude de configurations suivant le nombre, la taille et la disposition des pétales. Il s'adapte ainsi à n'importe quel projet d'éclairage. En effet la puissance de restitution et l'orientation du flux peuvent être adaptées selon le besoin d'éclairage.

Range

As Margo is available in a wide range of versions depending on the size, the number and the placement of the petals, the luminaire fits all kinds of lighting projects. Indeed the lighting level and the orientation of the luminous flux can be adapted depending on illumination needs.

Quelques exemples / A few examples

MARGO MINI



MARGO MEGA

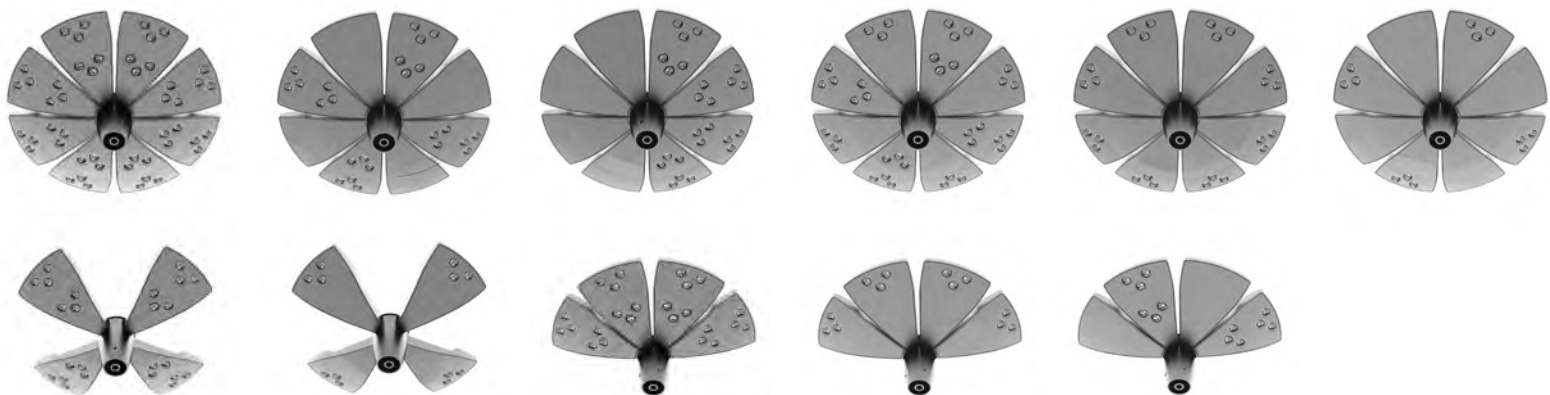

MARGO MIX

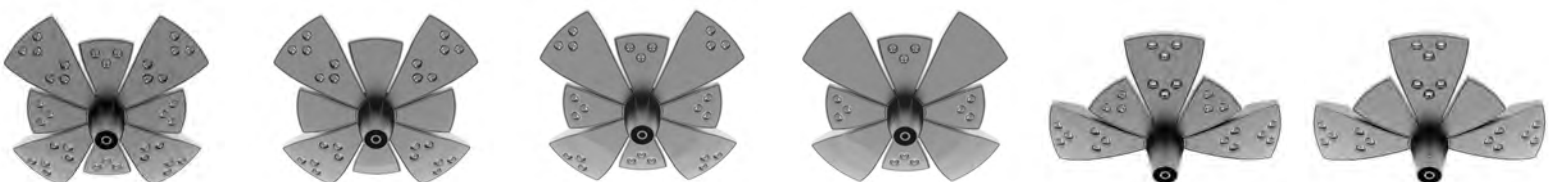



Caractéristiques techniques









Technical characteristics











Le Margo est un luminaire qui s'adapte à tout type de projet d'éclairage, grâce à sa grande modularité.

Margo is a luminaire which fits all kinds of lighting projects thanks to its high level of modularity.







En top Top mounted

									
	Margo MINI 4P 180° 12 LED	Margo MINI 4P 360° 12 LED	Margo MINI 8P 360° 24 LED	Margo MEGA 4P 180° 24 LED	Margo MEGA 4P 360° 24 LED	Margo MEGA 8P 360° 24 LED	Margo MEGA 8P 360° 48 LED	Margo MIX 5P 225° 24 LED	Margo MIX 8P 360° 36 LED
Poids (kg) Weight (kg)	6	6	10	9	9	11	14	10	12
Coefficient aérodynamique SC _x (m ²) Aerodynamic coefficient C _x S (m ²)	0.03			0.06					

Suspendu Suspended

									
	Margo MINI 4P 180° 12 LED	Margo MINI 4P 360° 12 LED	Margo MINI 8P 360° 24 LED	Margo MEGA 4P 180° 24 LED	Margo MEGA 4P 360° 24 LED	Margo MEGA 8P 360° 24 LED	Margo MEGA 8P 360° 48 LED	Margo MIX 5P 225° 24 LED	Margo MIX 8P 360° 36 LED
Poids (kg) Weight (kg)	6	6	10	9	9	11	14	10	12
Coefficient aérodynamique SC _x (m ²) Aerodynamic coefficient C _x S (m ²)	0.03			0.06					

Mural et contre poteau Wall-mounted or against a pole

						
	Margo MINI 1P 3 LED	Margo MINI 4P 180° 12 LED	Margo MINI 4P 180° 12 LED	Margo MEGA 1P 6 LED	Margo MEGA 4P 180° 12 LED	Margo MEGA 4P 180° 24 LED
Poids (kg) Weight (kg)	1	6	10	3	9	14
Coefficient aérodynamique SC _x (m ²) Aerodynamic coefficient C _x S (m ²)	0.02	0.03		0.06		

Énergie de choc (Corps) / Shock resistance (Body)

IK 10

Indice de protection (Bloc optique) / Protection index (Optical unit)

IP 66

Matériaux / Materials

Luminaire / Luminaire

Luminaire totalement fabriqué en fonderie d'aluminium injecté /
Luminaire entirely made of injected cast aluminium

Visserie / Screws

Acier inoxydable 304 / 304 stainless steel





Margo

MINI - MEGA - MIX



Caractéristiques techniques Technical characteristics

Dimensions (mm) / Dimensions (mm)

MARGO EN TOP / TOP MOUNTED

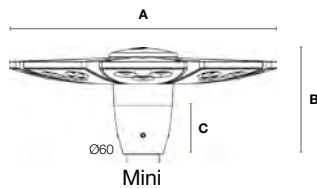

Mini

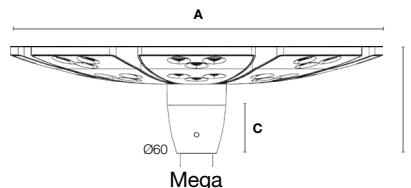

Mega

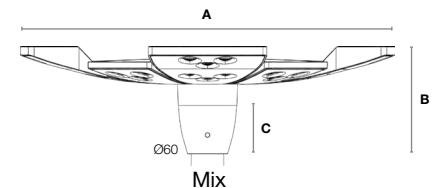

Mix

	A	B	C*
Margo Mini / Mini Margo	500	195	70
Margo Mega / Mega Margo	700	195	70
Margo Mix / Mix Margo	700	195	70

*Profondeur d'emmanchement /
Depth of insertion

MARGO SUSPENDU / SUSPENDED

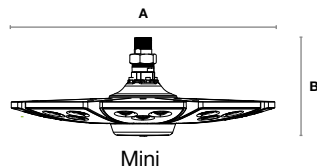

Mini

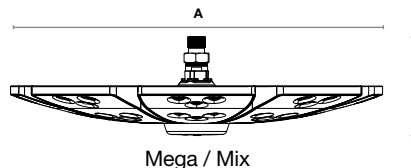

Mega / Mix

	A	B
Margo Mini / Mini Margo	500	185
Margo Mega / Mega Margo	700	185
Margo Mix / Mix Margo	700	185

MARGO MURAL ET CONTRE POTEAU / WALL-MOUNTED OR AGAINST A POLE

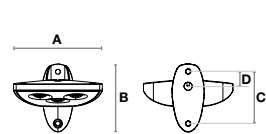

Mini 1P

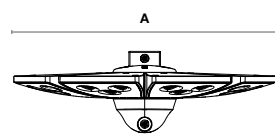

Mini 4P

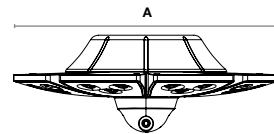

Mini 4P + cache appareillage /
Mini 4P + driver cover

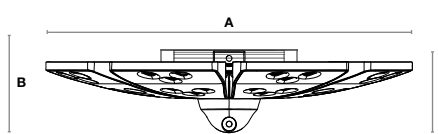

Mega 4P

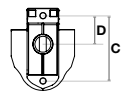

Patin Mini 4P + Mega 4P /
Mini 4P + Mega 4P fixing block

	A	B	C*	D**
Margo Mini 1P / Mini Margo 1P	164	125	95	27
Margo Mini 4P / Mini Margo 4P	500	152	125	54
Margo Mini 4P + cache / Mini Margo 4P + cover	500	182.5	125	54
Margo Mega 4P / Mega Margo 4P	700	152	125	54

*Entre-axes / Center to center

**Passage câble / Cable pass



Caractéristiques techniques Technical characteristics

Caractéristiques électriques

- Courant d'alimentation : jusqu'à 700 mA
- Classe électrique : classe II
- Driver déporté : externe au luminaire
- Varistance (protection contre les surtensions)
- En option systèmes de gestion de l'éclairage : abaissement automatique suivant horaires jusqu'à 5 paliers, détection de présence, flux constant, gradation par variation de tension, commande 1-10V ou DALI.

Electrical characteristics

- Power currents: up to 700 mA
- Electrical class: class II
- External driver: non-integrated in the luminaire
- Varistor (protection against high voltages)
- Optional lighting management systems: automatic time-related lowering of intensity with up to 5 levels, presence detection, constant flux, gradation by means of voltage variation, 1-10V or DALI control.

Gamme de tensions (V)* / Voltage range (V)*

Nombre de LED /
Number of LEDs

350 mA

500 mA

700 mA

3.....	9.....	9.36.....	9.9
6.....	18.....	18.72.....	19.8
9.....	27.....	28.08.....	29.7
12.....	36.....	37.44.....	39.6
15.....	45.....	46.80.....	49.5
18.....	54.....	56.16.....	59.4
21.....	63.....	65.52.....	69.3
24.....	72.....	74.88.....	79.2
27.....	81.....	84.24.....	89.1
30.....	90.....	93.60.....	99.0
33.....	99.....	102.96.....	108.9
36.....	108.....	112.32.....	118.8
39.....	117.....	121.68.....	128.7
42.....	126.....	131.04.....	138.6
45.....	135.....	140.40.....	148.5
48.....	144.....	149.76.....	158.4

*Sur la base d'une LED à 3 V @ 350 mA / *Based on a 3 V LED @ 350 mA





Margo

MINI · MEGA · MIX



Performances d'éclairage Lighting performance

Margo restitue un éclairage **performant, efficace et confortable** instaurant un sentiment de sécurité.

La **puissance d'éclairage est ajustable** suivant le besoin d'éclairage grâce aux déclinaisons du luminaire avec plus ou moins de LED. En ajoutant un driver spécifique on peut aussi programmer des variations de puissance.

Principe optique

Son système optique innovant et ultra-performant a été conçu pour offrir une bonne visibilité, limiter l'éblouissement et pour contrôler les nuisances lumineuses.

- Les lentilles ont été spécialement développées pour le module 3 LED de RAGNI, lui même conçu spécifiquement pour s'intégrer au Margo.
- Les lentilles étanches (IP 66) du luminaire sont la seule barrière que la lumière a à franchir.
- Grâce aux lentilles du module 3 LED, l'amélioration du rendement du luminaire combiné au contrôle optimal de la distribution lumineuse offre une excellente uniformité d'éclairage.
- La réduction des éblouissements et des nuisances lumineuses apporte un réel gain de confort.

Une nuit étoilée sans pollution lumineuse

Le Margo s'impose comme une solution d'avenir. Il a été conçu pour éviter la perte de flux lumineux vers le haut.

L'ULOR* du luminaire MARGO est égal à seulement 1,6%

**L'ULOR est le pourcentage du flux lumineux directement dirigé vers le haut.*

Pour les zones les plus sensibles, où les nuisances lumineuses doivent être réduites au plus bas, le Margo est une solution idéale.



Margo provides **high performance, effective and comfortable** lighting creating a feeling of safety.

The **level of the lighting can be adapted** depending on the needs thanks to the different versions of the luminaire with more or less LEDs. By adding a specific driver one can program variations of the level of lighting.

Optical principle

Its innovative, high-performance optical system has been designed to achieve great visibility, limited glare and to control light pollution.

- The lenses have been specially developed for RAGNI's 3 LED module. And the latter has been created specifically to integrate Margo.
- The airtight (IP 66) lenses of the luminaire are the only barrier that the light must go through.
- Thanks to the 3 LED module lenses, enhancement of the yield in terms of light combined with optimal control of its distribution ensures excellent lighting uniformity.
- A lower degree of glare and light pollution ensures real gains in terms of comfort.

A starry night with no light pollution

The Margo stands out as a solution for the future. It has been designed so as not to lose any light output above the fitting.

The MARGO ULOR* equals only 1.6%

**ULOR is the ratio between the upward luminous flux and the whole luminous flux.*

For the most sensitive zones to light pollution where it must be reduced to a minimum, the Margo is a great solution.





Performances d'éclairage Lighting performance

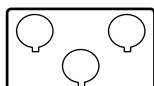

Module 3 LED

Nous avons sélectionné nos LED parmi les meilleures du marché pour leur qualité et leur efficacité. Le module 3 LED a été développé à l'occasion de la conception du Margo spécialement pour s'adapter au design du luminaire.

3 LED module

We selected the LEDs among the best on the market for their quality and efficiency. The 3 LED module has been developed during the Margo's design phase specially to be compatible with it.



- Fabricant LED : NICHIA
- Durée de vie des LED : 80 000 heures à 70% @ 700 mA
- Température de couleur : 3500K ou 4500K (autres températures de couleur sur demande)
- Développement VS Lighting Solutions (Groupe PANASONIC)
- IRC supérieur à 75
- Indice de protection : IP 66
- Module autogéré-thermiquement

- LED manufacturer: NICHIA
- LED life cycle: 80 000 hours at 70% @ 700 mA
- Color temperature: 3500K or 4500K (other color temperatures on request)
- Development by VS Lighting Solutions (PANASONIC group)
- CRI above 75
- Protection index: IP 66
- Thermally self-managed module

Puissances et intensités lumineuses

Grâce aux nombreuses déclinaisons de Margo, le choix d'intensité et du nombre de LED est multiple ce qui permet de l'adapter précisément aux besoins.

Power and luminous intensity

Margo's numerous variations give a multiple choice of intensity and the number of LEDs so that it can be adapted precisely to meet specific needs.

Nombre de LED Number of LEDs	175 mA			350 mA			500 mA			700 mA		
	P _t (W)	Φ (lm)	(lm/W)	P _t (W)	Φ (lm)	(lm/W)	P _t (W)	Φ (lm)	(lm/W)	P _t (W)	Φ (lm)	(lm/W)
3	2	160	80.00	4	320	80.00	6	420	70.00	8	560	70.00
6	4	320	80.00	8	640	80.00	11	840	76.36	16	1120	70.00
12	7	640	91.43	15	1280	85.33	21	1680	80.00	30	2240	74.67
24	14	1280	91.43	29	2560	88.28	41	3360	81.95	57	4480	78.60
36	21	1920	91.43	43	3840	89.30	61	5040	82.62	86	6720	78.14
48	29	2560	88.28	57	5120	89.82	82	6720	81.95	114	8960	78.60

P_t (W) = Puissance totale avec consommation driver intégrée / P_t (W) = Total power consumption including driver consumption
 Φ Flux nominal (lm) / Nominal flux (lm)
 Efficacité lumineuse (lm/W) / Luminous efficiency (lm/W)





Margo

MINI · MEGA · MIX



Performances d'éclairage Lighting performance

Photométrie

La grande modularité du luminaire Margo permet d'adapter la distribution lumineuse aux besoins d'éclairage. Margo est disponible :

- en éclairage symétrique circulaire à 360°, tout à fait adapté pour mettre en lumière des places ou des parkings.
- et en éclairage asymétrique à 180°, idéal pour éclairer le long de routes ou de chemins sans flux arrière.

Circulaire 360° / Circular 360°



Courbes isolux / Isolux curves

Courbes polaires / Polar curves

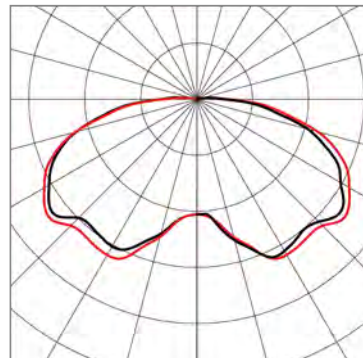

Photometry

Thanks to the high level of modularity of the Margo luminaire, light distribution can be adapted to meet lighting requirements. Margo is available:

- in 360° circular symmetrical lighting version, ideally suited to provide lighting for squares or car-parks.
- in 180° asymmetric lighting version, perfect to light up roads or paths without any light output to the rear.

Asymétrique 180° / Asymmetrical 180°



Courbes isolux / Isolux curves

Courbes polaires / Polar curves

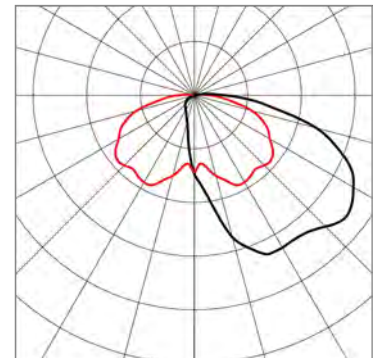
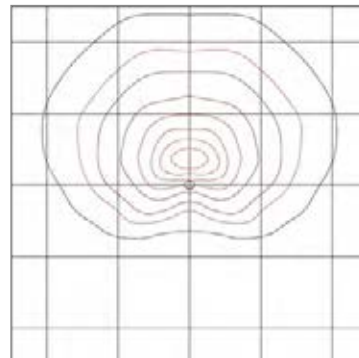

Simulation de projets d'éclairages / Simulation of lighting projects

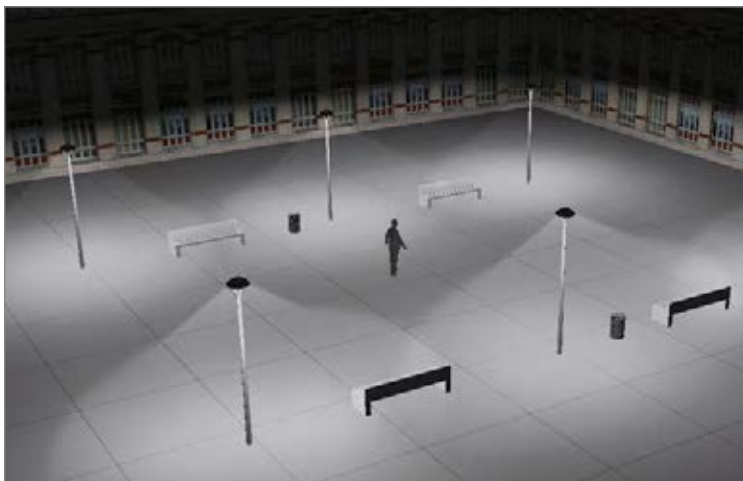

Eclairage 360° - symétrique circulaire (place, placette, piéton, parking...)
360° lighting - circular symmetric distribution (square, footpath, car park...)



Eclairage 180° - asymétrique (rue, ruelle, cheminement piéton...)
180° lighting - asymmetrical distribution (road, street, footpath...)



Margo
MINI - MEGA - MIX

Installation & maintenance

Installation & maintenance 

Installation

L'installation de Margo ne nécessite qu'un seul branchement et le système de fixation facilite la tâche.

DRIVER (branchement et emplacement) / DRIVER (connection and location)

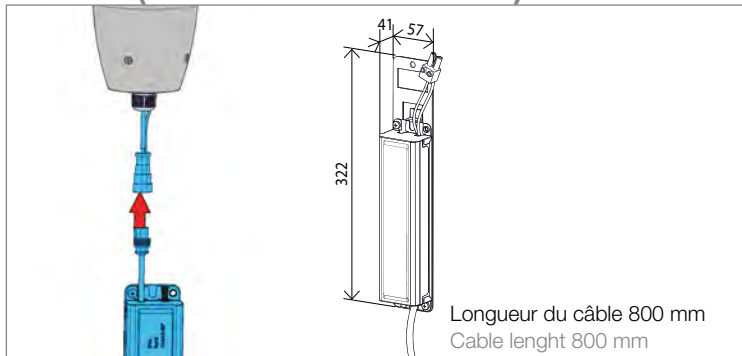

Un seul branchement est nécessaire pour connecter le driver.
Le driver est intégré en pied poteau.
Section tubulaire du candélabre minimum : Ø 76 mm.
Driver livré pré câblé (connecteurs IP67) sur platine
Only one connection is necessary to link up the driver despite the large number of LEDs. It will be at the foot of the pole.
Minimum tube cross-section of the pole to house the driver: Ø 76 mm.
Pre-wired Led driver with IP67 connectors mounted on support tray .

MURAL ET CONTRE POTEAU / WALL-MOUNTED OR AGAINST A POLE

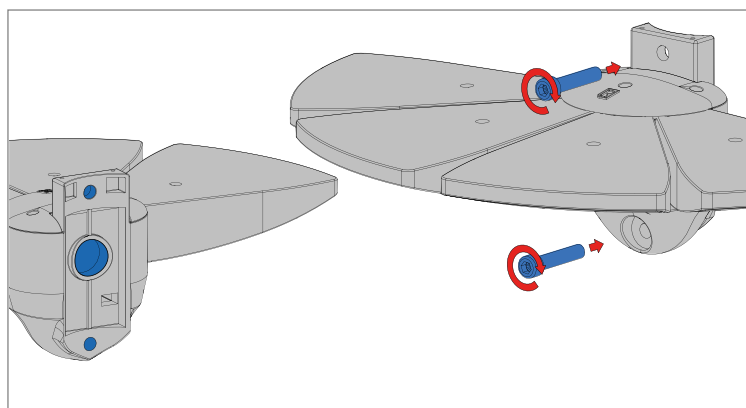

Fixation par 2 vis. Dimensions entre-axes et passage câble selon version.
Mounted with 2 screws. Center to center and cable pass dimensions depending on version.

Installation

The Margo's installation is very easy, thanks to its mounting system and because only one electrical connection is necessary.

EN TOP / TOP MOUNTED

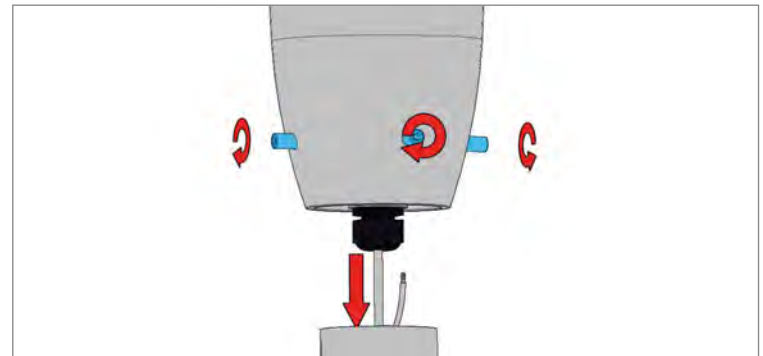

Alignement avec le mât garanti par les vis de réglage et de fixation.
Thanks to the adjustment and fixation screws the support is perfectly aligned with the pole.

Mât : Ø60 / Pole: Ø60
Epaisseur du mât : 10 mm maximum
Width of lamp pole: 10 mm maximum
Profondeur d'emmanchement : 70 mm / Depth of insertion: 70 mm

SUSPENDU / SUSPENDED

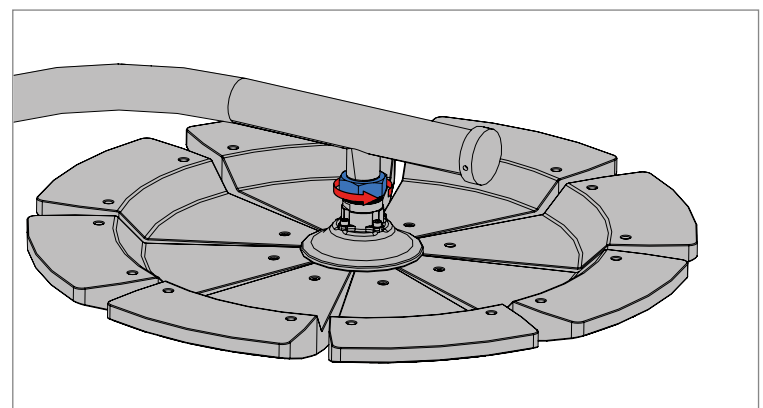

Raccord mâle 1" filetage GAZ.
Coupling 1" male pipe threads.



Margo

MINI · MEGA · MIX



Installation & maintenance

Maintenance

L'accès au cœur du luminaire, se fait simplement et par le dessus, en dévissant les deux vis imperdables prévues à cet effet. Ceci permet une rapidité de maintenance de chacune des versions du luminaire Margo.

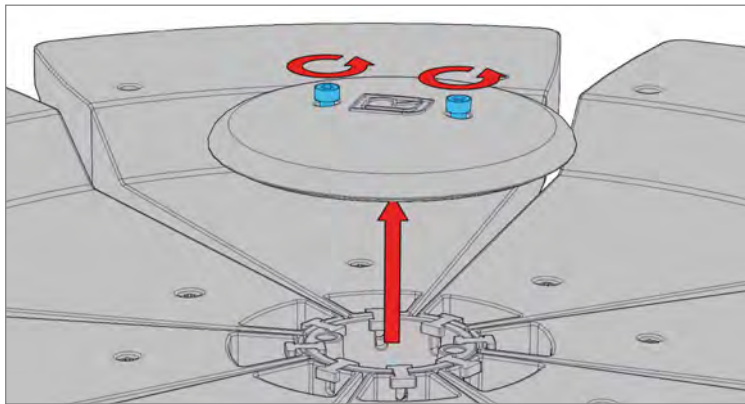

Démontage du chapeau.
Removal of the cover.

Maintenance

The heart of the luminaire is easily accessed from above by unscrewing the two captive screws designed for this purpose. This enables rapid maintenance for every version of Margo.

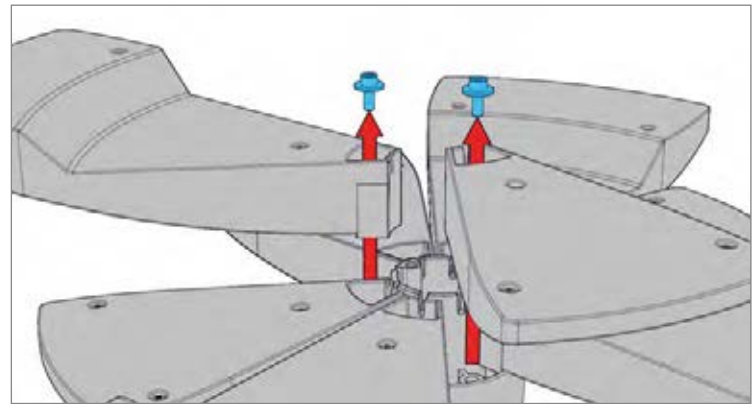

Possibilité de changer chaque pétale individuellement.
Each petal can be changed independently.





Margo
MINI - MEGA - MIX

**Esthétique
Appearance**



Le Margo est un luminaire unique, entièrement dessiné et développé par les équipes de RAGNI. Il se distingue par son design affirmé inspiré de la nature et sa modularité qui permet de proposer une multitude de versions et une personnalisation presque infinie.

Margo is a unique lighting solution, entirely designed and developed by the RAGNI teams. It is distinctive for its assertive design inspired by nature and its modularity, enabling it to propose a wide range of versions and almost infinite personalisation.

Types de fixation

Fixation murale et contre poteau

Une fixation murale ou contre un poteau est compatible avec toutes les déclinaisons du Margo jusqu'à quatre pétales disposés à 180°. Le driver est installé au-dessus du luminaire pour la version murale.

Fixation types

Wall-mounted or against a pole

Fixation on a wall or onto a pole is compatible with versions of the Margo of up to four petals arranged at 180°. For the wall-mounted version, the driver is placed above the luminaire.



Margo Mini 1P
Mural ou contre poteau
Mini Margo 1P
Wall-mounted or against a pole



Margo Mini mural
et cache appareillage
Wall-mounted Mini Margo
with driver cover



Margo Mini
contre poteau
Mini Margo
against a pole



Margo Mega
mural et contre poteau
Mega Margo
Wall-mounted or against a pole

Suspendu

La fixation suspendue est possible pour toutes les déclinaisons du Margo.

Suspended

All versions of the Margo can be ordered as suspended.



Margo Mini suspendu
Suspended Mini Margo



Margo Mega suspendu
Suspended Mega Margo



Margo Mix suspendu
Suspended Mix Margo





Margo

MINI - MEGA - MIX



Esthétique Appearance

En top de mât

La fixation en top est possible pour toutes les déclinaisons du Margo.

Top mounted

All versions of the Margo can be ordered as top-mounted.



Margo Mini en top
Top mounted
Mini Margo



Margo Mega ou Mix en top
Top mounted
Mega or Mix Margo

Flower Power

Pour garder l'esthétique de la fleur dans tous les cas, il existe des pétales factices. Ainsi, on peut par exemple combiner le rendu d'une fleur ronde avec un éclairage à 180°.

To retain, no matter what, the visual appeal of the flower, fake petals are available. One can, for example, combine the impression of a round flower with 180° lighting.



Margo Mini 360°
Mini Margo 360°



Margo Mini 180°
Mini Margo 180°



Margo Mini 180°
+ 4 pétales factices
Mini Margo 180°
+ 4 false petals





**METTEZ DE LA COULEUR
DANS VOTRE VILLE !**

PUT SOME COLORS IN YOUR CITY!





Margo

MINI · MEGA · MIX



Esthétique
Appearance

Le Margo se décline en une large palette de couleurs, ce qui permet une réelle personnalisation du produit.

- **Couleurs standards** : Gris 2900 sablé ou Noir Foncé RAL 9005.
- **Version multicolore** : Des couleurs différentes peuvent être choisies indépendamment pour ces différentes parties du luminaire :
 - l'embase et le chapeau,
 - le dessus et le contour des pétales,
 - et le dessous des pétales.

The Margo comes in a wide array of colors, allowing real personalisation of the product.

- **Standard colors**: Sanded Grey 2900 or dark Black 9005.
- **Multi-colored version**: Different colors can be chosen independently for the various parts of the lamp:
 - the base and lid,
 - the contour and top side of the petals,
 - the bottom of the petals.

Exemples de couleurs / Color examples

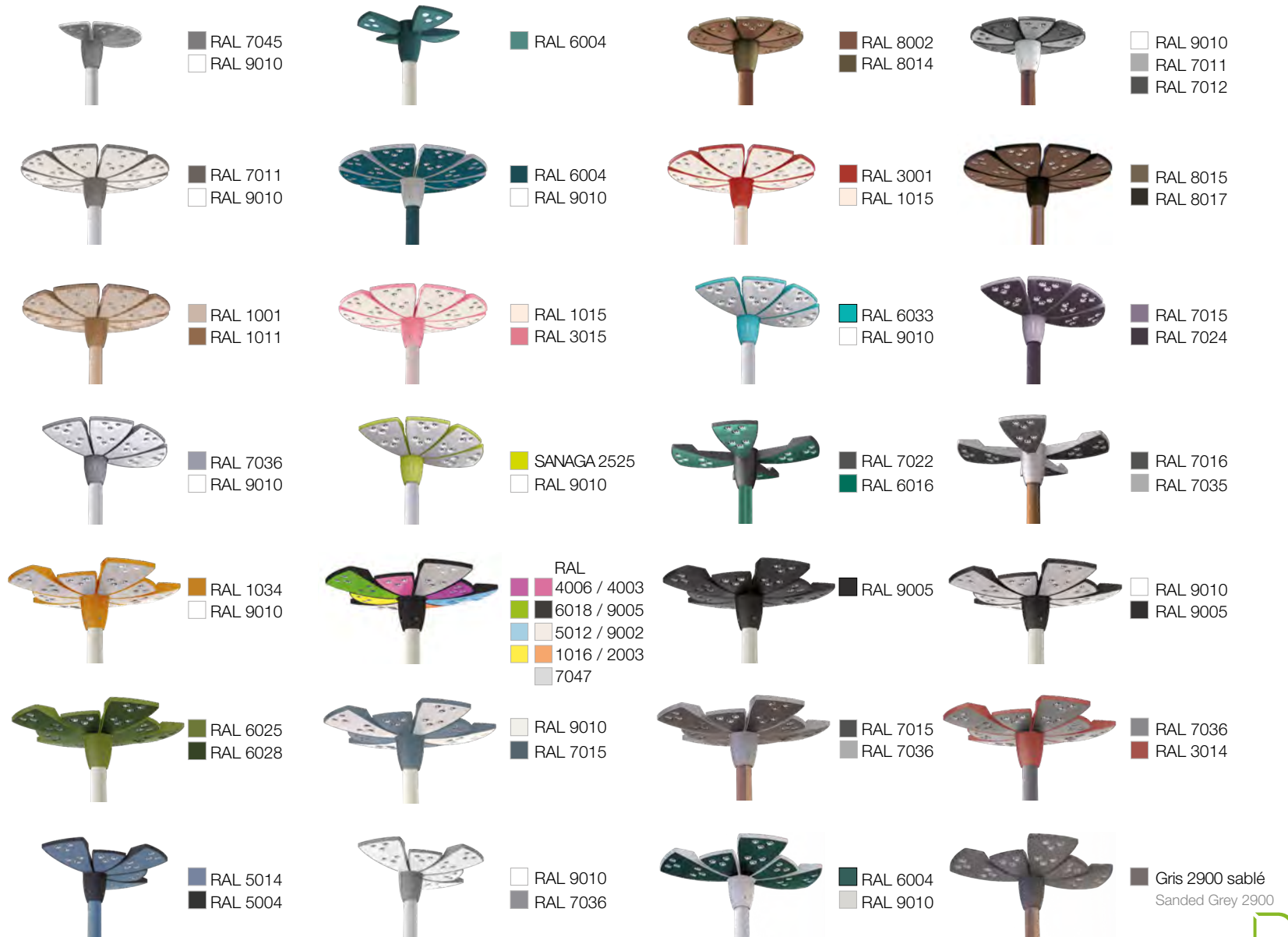



Margo
MINI - MEGA - MIX

Esthétique
Appearance 



Propositions d'ensembles
Suggestions of ensembles

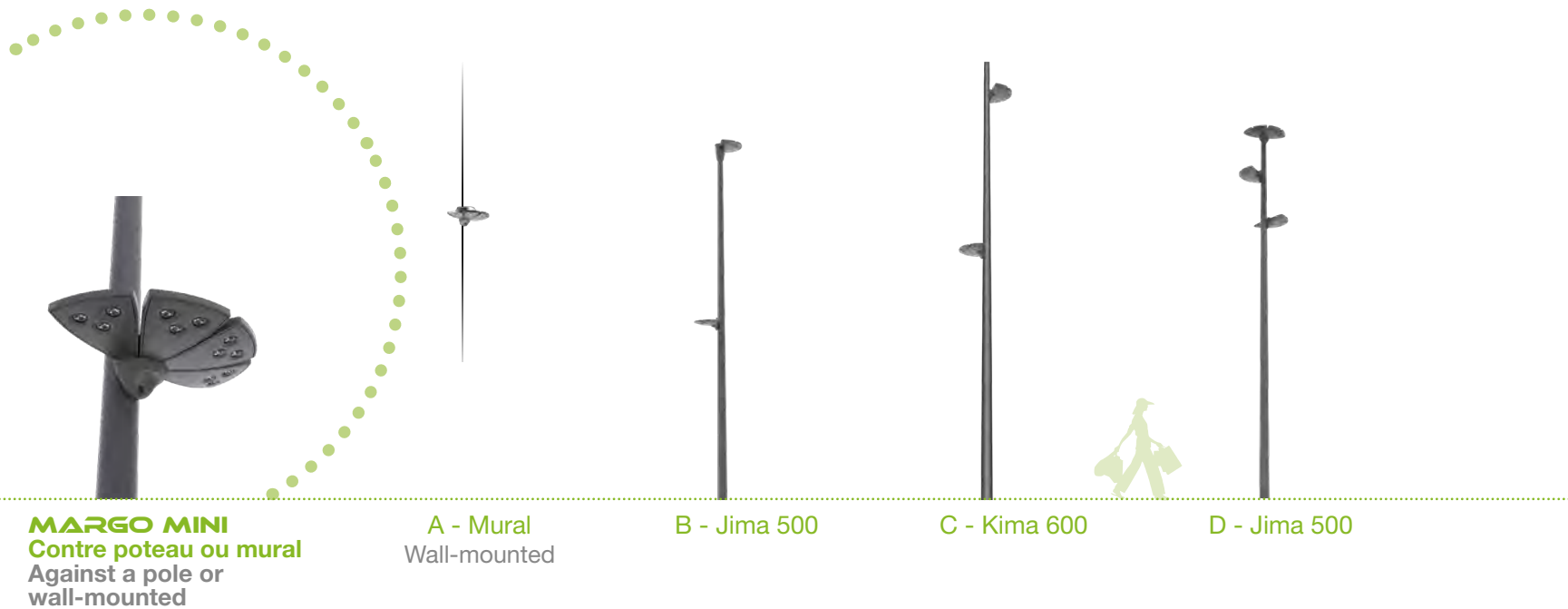
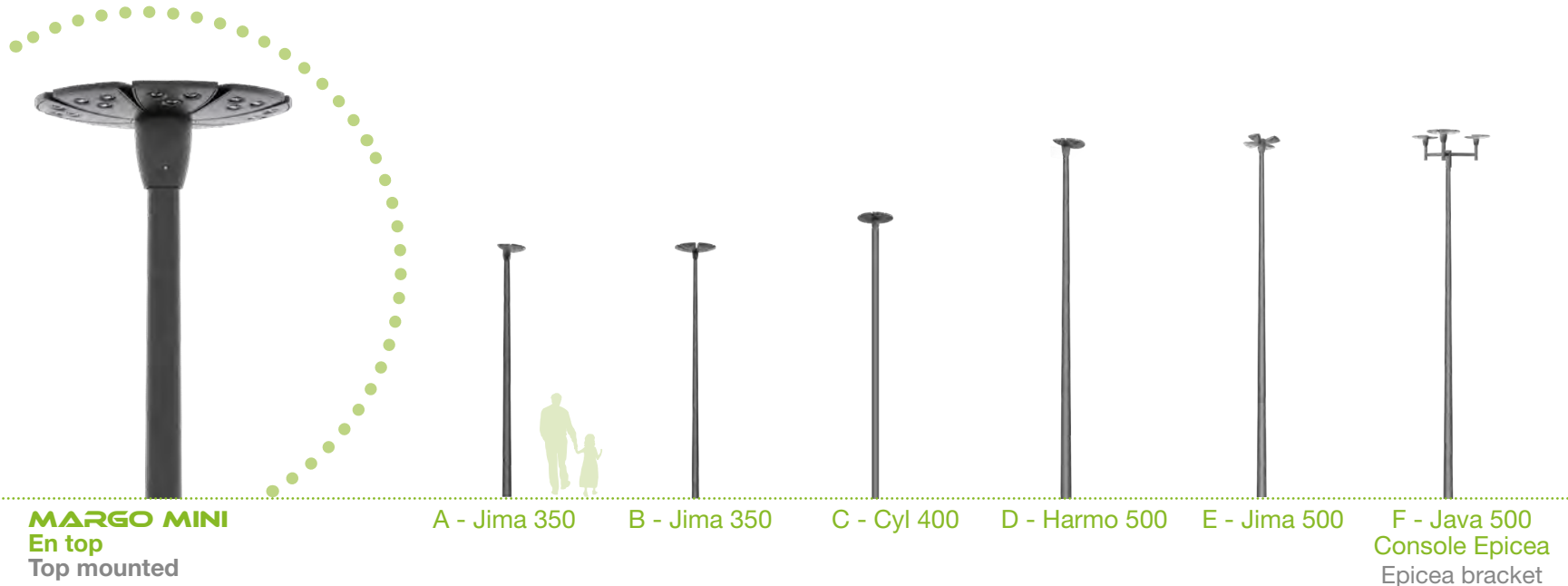

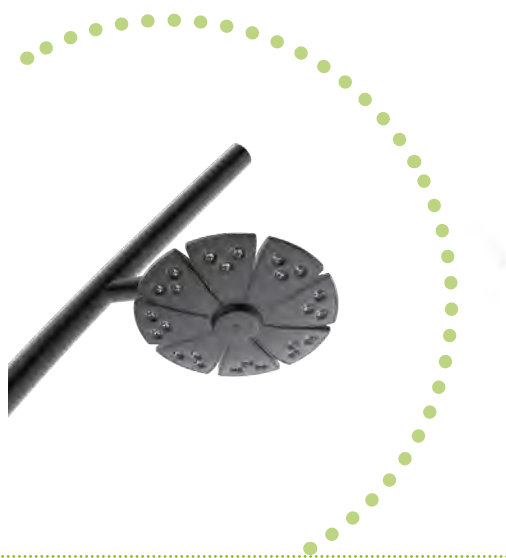

MARGO MINI
Suspendu
Suspended



A - Console Lycia Murale
Wall-mounted Lycia bracket



B - Curvi 400



C - Iro 400



D - Unia 600



MARGO MINI
Suspendu
Suspended



A - Jima 500
Console Olympia
Olympia bracket



B - Kima 600
Console Saint Andre
Saint Andre bracket



C - Jima 450
Console Saint Andre
Saint Andre bracket





Margo
MINI - MEGA - MIX

Esthétique
Appearance 



Propositions d'ensembles
Suggestions of ensembles

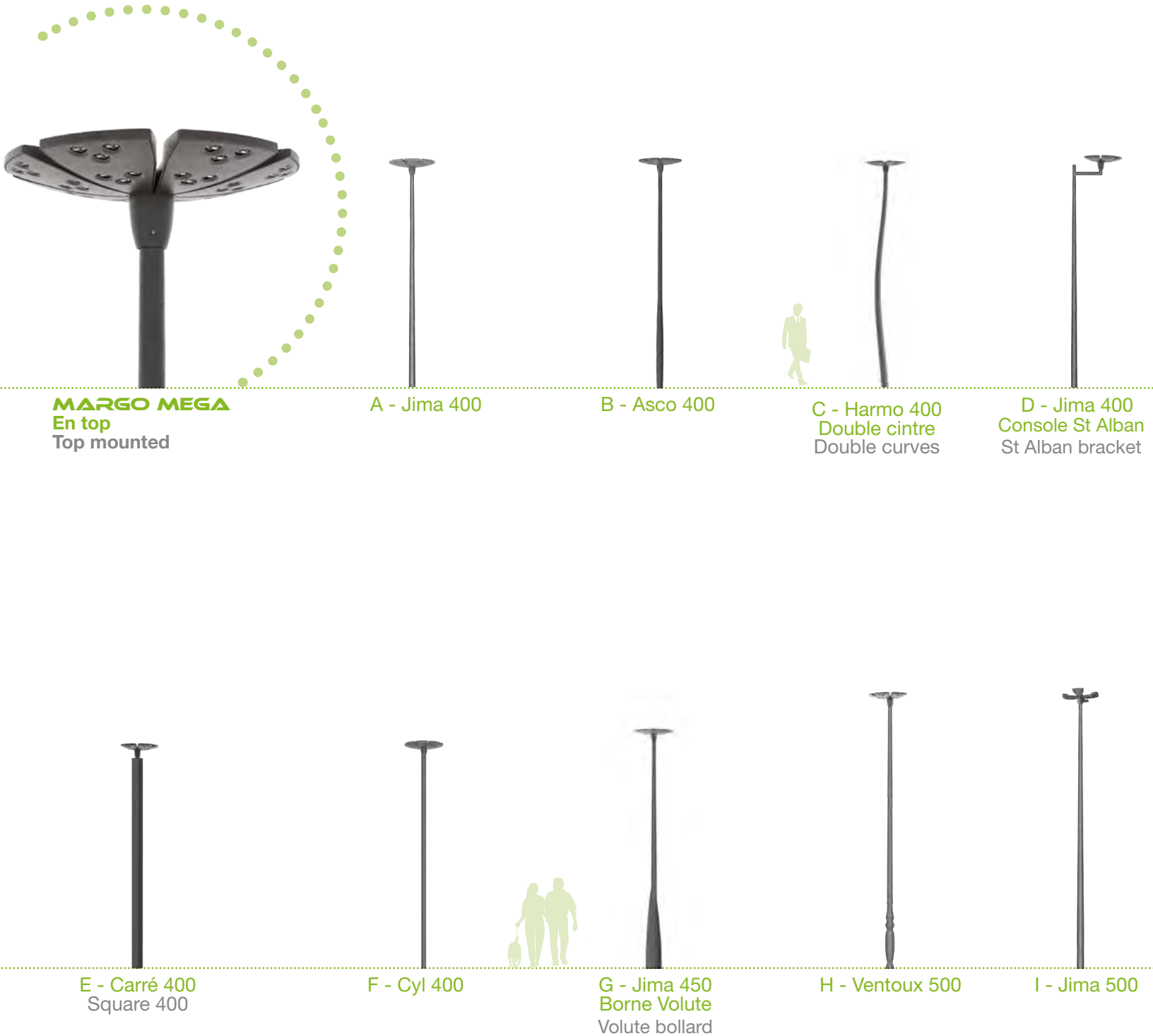



J - Jima 600
Console Urdas
Urdas bracket

K - Jima 500

L - Kima 600
borne Duna
Duna bollard

M - Harmo 600

N - Java 600
Console Atala
Atala bracket

O - Java 600
Console Atala
Atala bracket



MARGO MEGA
Contre poteau ou mural
Against a pole or
wall-mounted

A - Mural
Wall-mounted

B - Jima 400

C - Jima 600

D - Harmo 400
Double cintre
Double curves

E - Jima 600

F - Jima 500

G - Iro 600



Margo
MINI - MEGA - MIX

Esthétique
Appearance 



Propositions d'ensembles
Suggestions of ensembles



MARGO MEGA
Suspendu
Suspended



A - Iro 500



B - Kima 700
Console Denisia
Denisia bracket



C - Unia 600 - 400



D - Harmo 400
Console Elina
Elina bracket



F - Iro 600

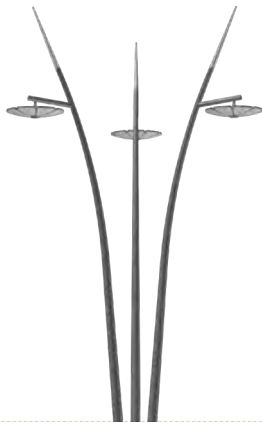

G - Iro 400



H - Unia 500



I - Iro 800



J - Iro 400 - 600



MARGO MIX
En top
Top mounted

A - Jima 350

B - Harmo 400

C - Jima 400

D - Kima 600



MARGO MIX
Suspendu
Suspended

A - Unia 400

B - Iro 500

C - Curvi 600

D - Iro 700



Margo
MINI - MEGA - MIX

Esthétique
Appearance 

Gamme Margo & mobilier urbain *design by Mauro Belli*

Composition de l'ensemble :

- Margo en top versions au choix.
- Un ou plusieurs mâts entrelacés (hauteurs et courbures différentes).
- Possibilité d'associer l'ensemble avec du mobilier urbain type pot de fleur ou banc.

Margo & urban furniture range *design by Mauro Belli*

Ensemble composition:

- Any top-mounted Margo.
- One or more intertwined pole(s) (different heights and curves).
- Possibility of combining the ensemble with urban furniture of the flowerpot or bench type.

