



# HYSION 海雄机械

## PLASTIC INJECTION MOLDING MACHINE



### HXF 188 PET Preform Injection Molding Machine

#### Technical Parameters:

MODEL: HXF 188PET			
TECHNICAL PARAMETER TABLE			
INJECTION UNIT	SCREW DIAMETER	mm	50
	SCREW L/D RATIO	L/D	25
	INJECTION CAPACITY (THEORETICAL)	cm <sup>3</sup>	441
	INJECTION WEIGHT(PS)	g	463
	INJECTION PRESSURE	MPa	143
	INJECTION RATE	g/s	179
	PLASTICIZING CAPACITY	g/s	25
	SCREW SPEED	rpm	160
CLAMPING UNIT	CLAMP FORCE	KN	1880
	OPEN STROKE	mm	450
	MAX. MOULD HEIGHT	mm	530
	MIN. MOULD HEIGHT	mm	180
	SPACE BWTWEEN TIE-BARS (W×H)	mm	510×460
	EJECTOR FORCE	KN	53
	EJECTOR STROKE	mm	130

**Ningbo Jiangdong HYSION Machinery Co., Ltd.**

**Address:** No.36 Yongjiang South Road, Beilun District, Ningbo, Zhejiang, China

**Tel:** 86-574-27858986

**Fax:** 86-574-27858980

**Email:** [haixiongmac@gmail.com](mailto:haixiongmac@gmail.com)

[geweicun@163.com](mailto:geweicun@163.com)



# HYSION 海雄机械

## PLASTIC INJECTION MOLDING MACHINE

	EJECTOR NUMBER	n	5
OTHERS	PUMP PRESSURE	MPa	16
	MOTOR POWER	KW	18.5
	HEATING POWER	KW	14.55
	MACHINE DIMENSION (L×W×H)	m	5.69×1.38×2.08
	MACHINE WEIGHT	t	5.3

### PET Preform Injection Molding Machine Dimensions

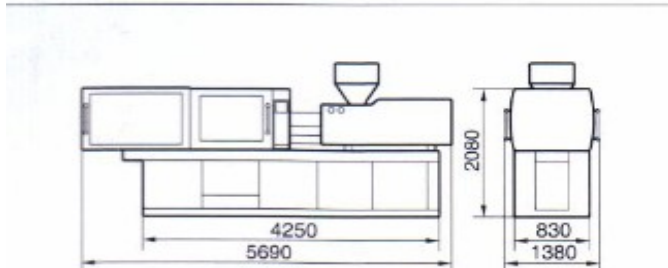
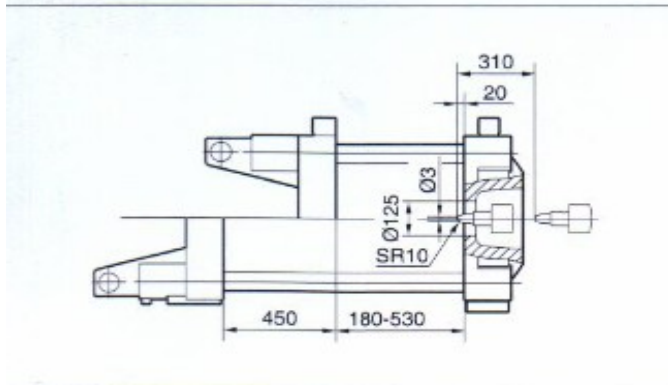
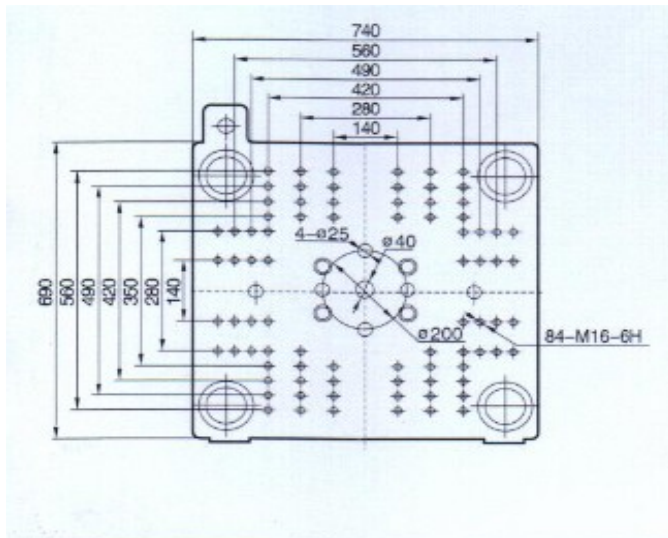

**Ningbo Jiangdong HYSION Machinery Co., Ltd.**

**Address:** No.36 Yongjiang South Road, Beilun District, Ningbo, Zhejiang, China

**Tel:** 86-574-27858986

**Fax:** 86-574-27858980

**Email:** [haixiongmac@gmail.com](mailto:haixiongmac@gmail.com)

[geweicun@163.com](mailto:geweicun@163.com)