

MD 1100

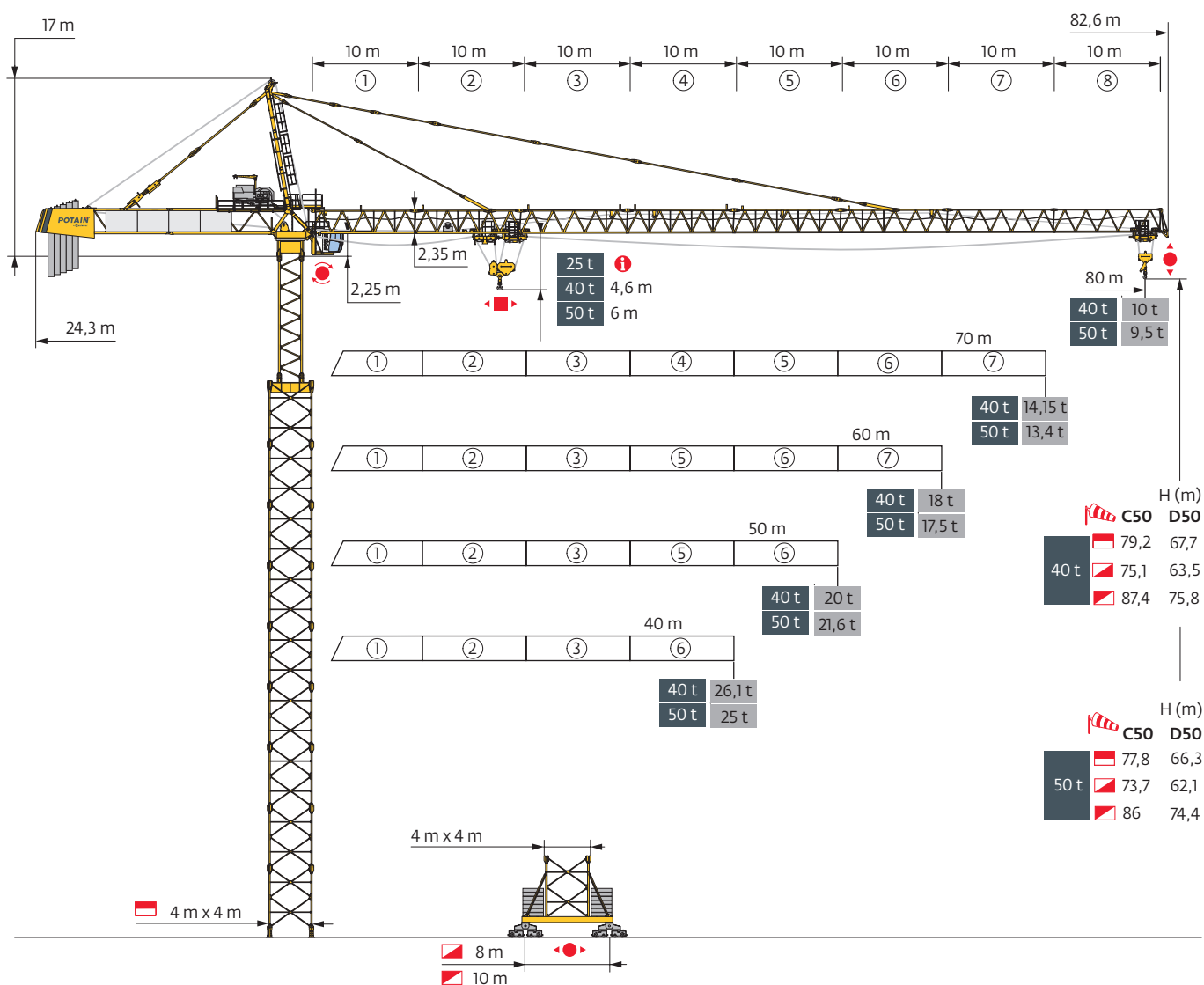

Power Control

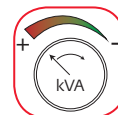

Anti-collision system

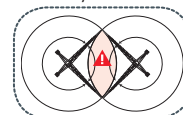

Mât - Réactions / Mast - Reaktionskräfte / Mast - Reactions / Mástil - Reacciones / Torre - Reazioni
 Tramo - Reacções / Реакция опор мачты

4 m
 40 m → 80 m

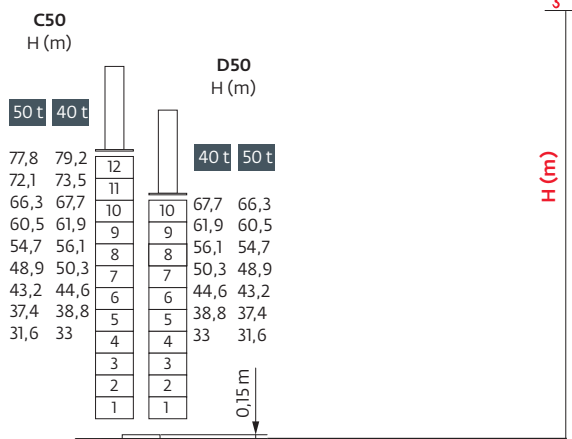
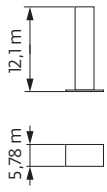

PA 951			
	C50	D50	
F2	• 272 t ■ 363 t	• 245 t ■ 353 t	
F3	• 116 t ■ 232 t	• 96 t ■ 229 t	
	195 t	182 t	

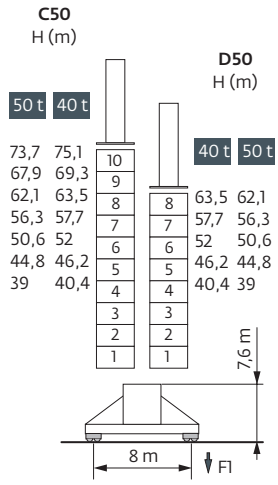

HA 950			
	C50	D50	
F1	• 218 t ■ 229 t	• 203 t ■ 227 t	
	217 t	207 t	

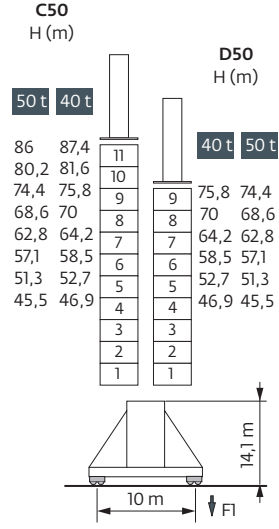

JA 951			
	C50	D50	
F1	• 227 t ■ 279 t	• 222 t ■ 288 t	
	258 t	244 t	

Autres implantations / Aufstellmöglichkeiten / Mounting possibilities / Otras implantaciones / Altre postazioni
 Outras implantações / Возможности установки

H (m) > 100 m ⓘ

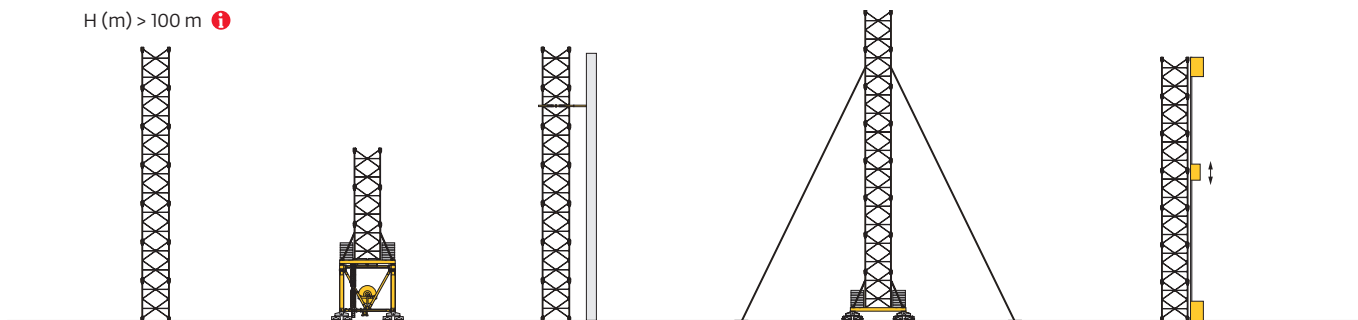

Courbes de charges / Lastkurven / Load curves / Curvas de cargas / Curve di carico
 Curvas de carga / Кривые нагрузок



40 t

80 m	5,7	▶	22,9	25	30	35	40	40,9	45,3	50	55	60	65	70	75	80	m
▲▲▲▲			40	36,2	29,3	24,3	20,6	20	→20	17,8	15,9	14,4	13	11,9	10,9	10	t
70 m	5,7	▶	26,2	30	35	40	45	47,3	52	55	60	65	70				m
▲▲▲▲			40	34,4	28,8	24,6	21,3	20	→20	18,8	17	15,5	14,15				t
40 m/50 m/60 m	5,7	▶	27,6	30	35	40	45	47	50	54,7	60						m
▲▲▲▲			40	36,4	30,5	26,1	22,7	21,5	20	→20	18						t

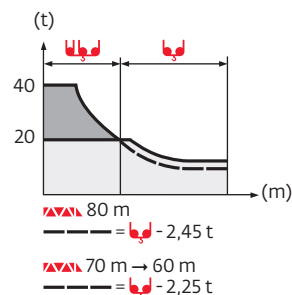

50 t

80 m	5,7	▶	18,5	20	25	30	33,3	36,7	40	45	50	55	60	65	70	75	80	m
▲▲▲▲			50	45,8	35,4	28,4	25	→25	22,6	19,7	17,4	15,5	13,9	12,5	11,4	10,4	9,5	t
70 m	5,7	▶	20,7	25	30	35	37,4	41,2	45	50	55	60	65	70				m
▲▲▲▲			50	40,4	32,6	27,1	25	→25	22,6	20	17,9	16,2	14,7	13,4				t
40 m/50 m/60 m	5,7	▶	22,1	25	30	35	40	44	45	50	55	60						m
▲▲▲▲			50	43,5	35,3	29,4	25	→25	24,4	21,6	19,4	17,5						t

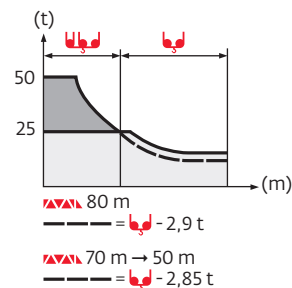

50 t

70 m	5,7	▶	19,8	20	25	30	34,6	35,8	40	45	50	55	60	65	70			m
▲▲▲▲			50	49,4	37,9	30,2	25	→25	21,6	18,4	15,8	13,7	11,9	10,4	9,1			t
40 m/50 m/60 m	5,7	▶	21,1	25	30	35	36,8	38,1	40	45	50	55	60					m
▲▲▲▲			50	40,9	32,6	26,7	25	→25	23,4	20	17,2	15	13,1					t

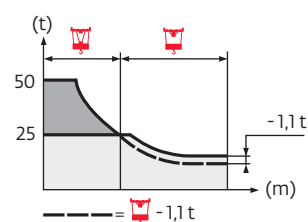

Lest de base / Grundballast / Base ballast / Lastre de base / Zavorra di base
 Lastro da base / Базовый Балласт

4 m	HA 950 C50 D50	40 t	H (m)	75,1	69,3	63,5	57,7	52	46,2	40,4	
			(t)	140	140	140	120	120	120	120	
			(t)	-	-	140	120	120	120	120	
	JA 951 C50 D50		H (m)	87,4	81,6	75,8	70	64,2	58,5	52,7	46,9
			(t)	160	120	80	80	80	80	80	80
			(t)	-	-	200	120	80	80	80	80

4 m	HA 950 C50 D50	50 t	H (m)	73,7	67,9	62,1	56,3	50,6	44,8	39	
			(t)	140	140	140	120	120	120	120	
			(t)	-	-	140	120	120	120	120	
	JA 951 C50 D50		H (m)	86	80,2	74,4	68,6	62,8	57,1	51,3	45,5
			(t)	160	120	80	80	80	80	80	80
			(t)	-	-	200	120	80	80	80	80

Lest de contre-flèche / Gegenauslegerballast / Counter-jib ballast / Lastre de contra-flecha / Zavorra di controbraccio
 Lastro da contra lança / Противовес стрелы

	13350 kg	12000 kg	10500 kg	(kg)
80 m	5	0	0	66750
70 m	4	1	0	65400
60 m	4	0	0	53400
50 m	0	3	1	46500
40 m	2	0	1	37200

CBM - 13350 kg

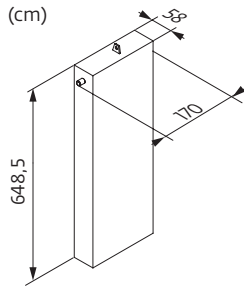

CAY - 12000 kg

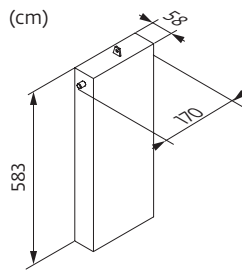

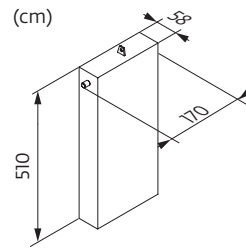

CAS - 10500 kg







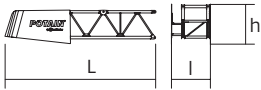
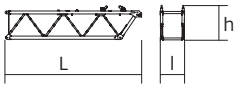
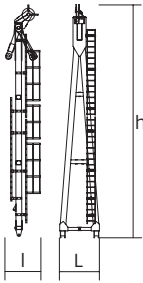
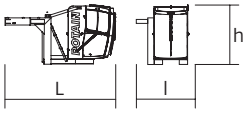
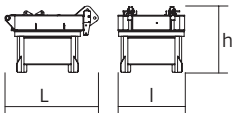
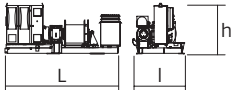
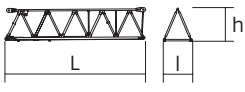
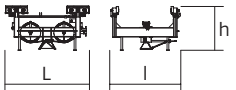

Encombremet et poids / Abmessungen und Gewicht / Dimensions and weight / Dimensiones y peso / Ingombro e peso
dimensões e pesos / габаритные размеры и вес

Partie tournante / Drehender Kranteil / Slewing crane part / Parte giratoria

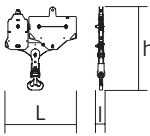
Parte rotante / Parte rotativa / Поворотная часть :  80 m -  40 t -  270 LVF



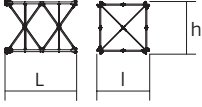
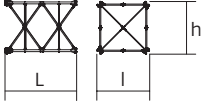
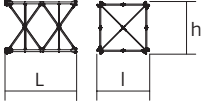
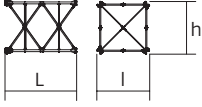















Partie tournante / Drehender Kranteil / Slewing crane part Parte giratoria / Parte rotante / Parte rotativa Поворотная часть	L (m)	I (m)	h (m)	kg (+/- 5%)		
Contre-flèche / Gegenausleger Counter-jib / Contra-flecha Controbraccio / Contra-lança Контр-стрела		12,9	2,8	2,9	7935	
		12	2,25	2,95	10200	
Porte-flèche / Auslegerträger Cathead / Porta-flecha Cuspide / Suporte de lança Оголовок		2,15	1,65	12,5	4550	
Cabine / Kabine Cab / Cabina Cabina / Cabina Кабина		-	-	-	-	
Pivot / Krankopf Towerhead / Pivote Portaralla / Pivot Секция поворотной части		3,9	2,8	2,75	24000	
Treuil de levage (+ câble) / Hubwerk (+ Seil) Hoisting winch (+ rope) / Mecanismo de elevación (+ cabo) Argano di sollevamento (+ fune) Guincho de elevação (+ cabo) Подъемная лебедка (+ канатом)		270 LVF (40 t)	5,09	2,3	2,24	9885
Élément de flèche / Auslegerelement Jib section / Elemento de flecha Elemento di braccio / Elemento de lança Секция стрелы		①	10,35	2,15	2,35	5020
		② 15 DVF	10,4	1,9	2,35	6100
		③	10,4	1,9	2,3	3765
		④	10,4	1,9	2,3	3545
		⑤	10,4	1,9	2,3	3490
		⑥	10,35	1,9	2,3	3545
		⑦	10,25	1,9	2,25	2775
		⑧	10,25	1,9	2,2	1905
Chariot / Laufkatze Trolley / Carrello Carro / Carro-distribuidor Тележка			2,6	2,35	1,45	1150
			2,75	2,4	1,3	1265
Moufle / Hubflasche Pulley block / Aparejo Bozzello / Cadernal Полиспаст			2,5	0,35	2,8	1325

Рүлбне / Kranturm / Crane tower Mástil / Torre / Torre Башня крана	L (m)	I (m)	h (m)	kg (+/- 5%)
Coulisse / Gleitstück Slider / Corredera Scorrimento / Tramo interior de telescopagem выдвигная мачта	11,75	2,55	2,55	14600
Bas de coulisse / Gleitstückunterteil Slider base / Parte baja de corredera Parte inferiore di scorrimento Base do tramo interior de telescopagem основание выдвигной мачты	4,45	1,85	4,45	11220
R 99A R 98A R 98B R 98C R 97B R 96D			h h h	7570 6815 6855 6835 6135 4325
Bases / Kranbasen / Crane bases Bases / Basi / Bases фундамент под кран			4 m	

Mécanismes / Triebwerke / Mechanisms / Mecanismos / Meccanismi
 Mecanismos / Механизмы

400 V - 50 Hz														ch - PS hp	kW	
	270 LVF 100 Optima	40 t	m/min t	51 20	66,5 15	96 10	139 5	162 3,5	25,5 40	33,5 30	49 20	71 10	81 8	270	200	532 m
	270 LVF 125 Optima	50 t	m/min t	39 25	51 18,75	73 12,5	108 6,25	122 3,6	20 50	26 37,5	36 25	54 12,5	61 9,6	270	200	841 m
	15 DVF 16	40 t	m/min	0 → 33 (40 t) 0 → 50 (20 t) 0 → 67 (10 t) 0 → 100 (2,5 t)									15	11		
	25 DVF 25	50 t	m/min	0 → 33 (50 t) 0 → 66 (25 t) 0 → 90 (12,5 t) 0 → 115 (6,25 t)									25	18,5		
	RVF 192-18 Optima+		tr/min U/min rpm	0 → 0,6									2 x 25	2 x 18,5		

IEC 60204-32	kVA
400 V (+10% -10%) 50 Hz	270 LVF / 15 DVF: 268 → 160 kVA 270 LVF / 25 DVF : 276 → 168 kVA

	FR	DE	EN	ES	IT	PT	RU
	Profil de vent suivant EN 14439 C50-D50	Windbedingungen gemäss EN 14439 C50-D50	Wind conditions according to EN 14439 C50-D50	Conformidad de los condiciones de viento EN 14439 C50-D50	Condizioni del vento secondo EN 14439 C50-D50	Perfil de vento conforme EN 14439 C50-D50	Ветровой режим в соответствии с EN 14439 C50-D50
	Équipements standards	Standardausrüstungen	Standard equipment	Equipamiento de serie	Equipaggiamento standard	Equipamento de série	Стандартное оборудование
	Équipements optionnels	Sonderausrüstungen	Options	Equipamiento opcional	Equipaggiamento in opzione	Equipamento opcional	Дополнительное оборудование (опция)
	Réactions en service	Reaktionskräfte in Betrieb	Reactions in service	Reacciones en servicio	Reazioni in servizio	Reacções em serviço	Реакция при работе
	Réactions hors service	Reaktionskräfte außer Betrieb	Reactions out of service	Reacciones fuera de servicio	Reazioni fuori servizio	Reacções fora de serviço	Реакция в покое
	Poids à vide sans lest avec flèche et hauteur maximum	Gewicht ohne Last, ohne Ballast, mit Ausleger und max. Höhe	Weight without load, without ballast, with jib and max. height	Peso en vacío sin lastre, con flecha y altura máxima	Peso a vuoto, senza zavorra, con braccio e altezza massimi.	Peso em vazio sem lastro com lança e altura máxima.	Вес пустого, без балласта, со стрелой, максимальной высоты.
	Poids total du lest	Ballast-Gesamtgewicht	Total ballast weight	Peso total del lastre	Peso totale della zavorra	Peso total do lastro	Общий вес балласта
	Camion 13,4 m	Lkw 13,4 m	Lorry 13,4 m	Camión 13,4 m	Camion 13,4 m	Camião 13,4 m	Ррузовой автомобиль 13,4 м
	Conteneur High Cube 40', et/ou Flat Rack 20'	Container High Cube 40', und/oder Flat Rack 20'	Container High Cube 40', and/or Flat Rack 20'	Contenedor High Cube 40', y/o Flat Rack 20'	Container High Cube 40', e/o Flat Rack 20'	Contentor High Cube 40', e/ou Flat Rack 20'	40-футовый контейнер повышенной вместимости High Cube, и/или 20-футовая открытая платформа Flat Rack
	Levage	Heben	Hoisting	Elevarción	Sollevarmento	Elevação	Подъем
	Distribution	Katzfahren	Trolleying	Distribución	Ditribuzione	Distribuição	Перемещение по стреле
	Orientation	Schwenken	Slewing	Orientación	Rotazione	Rotação	Поворот
	Translation	Kranfahren	Travelling	Traslación	Traslazione	Translação	Перемещение крана
	Puissance requise	Erforderliche Leistung	Required power	Potencia Necesaria	Potenza richiesta	Potência Necessária	Потребляемая мощность
	Fonction Power Control : vitesses treuils adaptées à la puissance disponible	Funktion Power Control: Geschwindigkeiten der Triebwerke werden an die verfügbare Leistung angepasst	Power Control Function: winch speeds adapted to the available power	Función Power Control: marchas de los cabrestantes adaptadas a la potencia disponible	Funzione Power Control: velocità degli argani adattate alla potenza disponibile	Função Power Control: velocidades de guincho adaptadas à potência disponível	Функция контроля мощности Power Control: регулировка скорости лебедок в зависимости от доступной мощности
	Nous consulter	AufAnfrage	Consult us	Consultarnos	Consultateci	Consultar-nos	Проконсультируйтесь у нас
	Document commercial non contractuel. Pour toute information technique se référer à la notice correspondante.	Unverbindliches Vertriebsdokument. Für technische Informationen, siehe die entsprechenden Anweisungen.	This commercial document is not legally binding. For any technical information, please refer to the corresponding instructions.	Documento comercial no contractual. Para cualquier información técnica, ver la noticia correspondiente.	Documento commerciale non vincolante, per tutte le informazioni tecniche fare riferimento al catalogo istruzioni.	Documento comercial não contratual. Para qualquer informação técnica complementar consultar as respectivas instruções.	Этот коммерческий документ не является юридически обязательным. Для получения технической информации, см. соответствующие инструкции.

