

TYPE 017AGM



Informations générales

Référence abrégée	017AGM
Unité d'emballage	1
Palettisation	48 pièces
Code EAN	5060106061358

Informations Techniques

Voltage [V]	12	Longueur [mm]	354
Capacité C20 AH	95	Largeur [mm]	175
CCA (EN) AMPS	850	Hauteur [mm]	190
Borne	1	Taille de bac	L5
Polarité	0	Listeau	B13
Type de couvercle	Kamina	Couleur	NOIR
Poids en Kg	24,9 kg		

Technologie

Type	AGM	Type d'alliage	CA/CA
Type de Grille	Métal déployé	Electrolyte	1,28g/cm3
Séparateur	PE		

Schéma



Photo

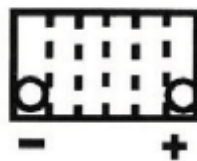

Polarité

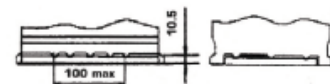

Listeau

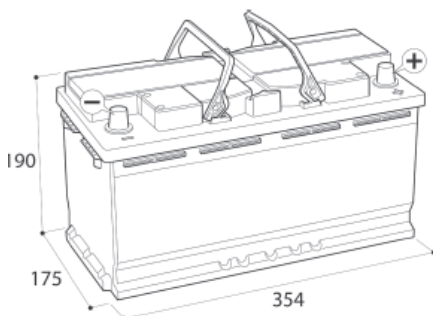

Schéma

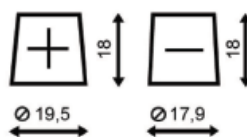

Borne

TRANSPORT INFORMATION

- Classified as "Batteries, Wet, Non - Spillable".
- UN2800
- Class 8
- Packing Group - N/A